

FOR MORE EXCLUSIVE
(Civil, Mechanical, EEE, ECE)
ENGINEERING & GENERAL STUDIES
(Competitive Exams)

TEXT BOOKS, IES GATE PSU's TANCET & GOVT EXAMS
NOTES & ANNA UNIVERSITY STUDY MATERIALS

VISIT

www.EasyEngineering.net

**AN EXCLUSIVE WEBSITE FOR ENGINEERING STUDENTS &
GRADUATES**



****Note:** Other Websites/Blogs Owners Please do not Copy (or) Republish this Materials without Legal Permission of the Publishers.

****Disclimers :** EasyEngineering not the original publisher of this Book/Material on net. This e-book/Material has been collected from other sources of net.

NEW AGE

FOURTH EDITION

BASIC ELECTRICAL ENGINEERING

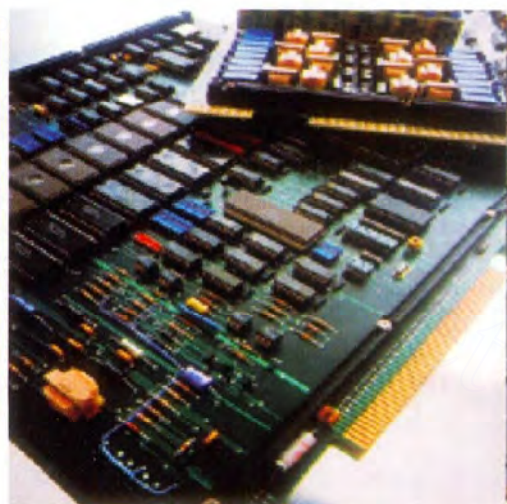
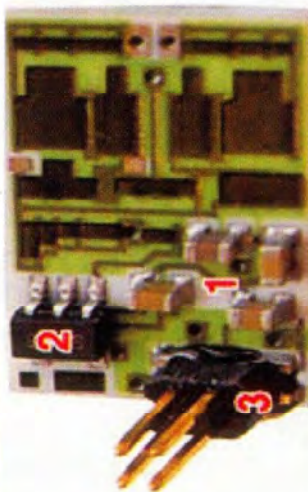
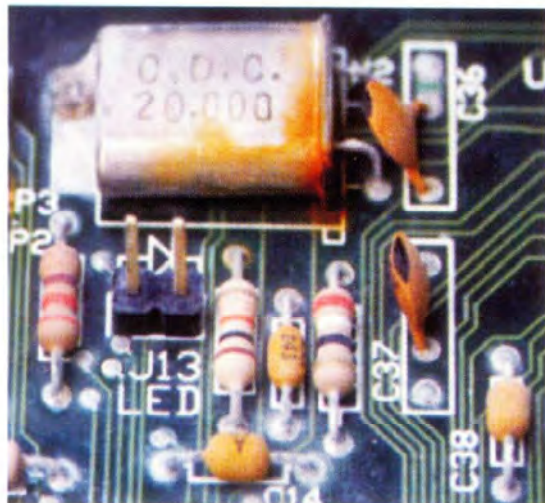

C. L. Wadhwa



NEW AGE INTERNATIONAL PUBLISHERS

BASIC ELECTRICAL ENGINEERING

www.EasyEngineering.net
EASY
ENGINEERING
© Apprise Education, Reprise Innovations ©
www.EasyEngineering.net

**This page
intentionally left
blank**

www.EasyEngineering.net
ENGINEERING
© Apprise Education, Reprise Innovations ©

BASIC ELECTRICAL ENGINEERING

FOURTH EDITION

C. L. Wadhwa

Formerly Professor
Department of Electrical Engineering
Delhi College of Engineering, Delhi
Formerly Dean
Faculty of Technology
University of Delhi, Delhi



PUBLISHING FOR ONE WORLD

NEW AGE INTERNATIONAL (P) LIMITED, PUBLISHERS

New Delhi • Bangalore • Chennai • Cochin • Guwahati • Hyderabad
Jalandhar • Kolkata • Lucknow • Mumbai • Ranchi

Visit us at www.newagepublishers.com

Copyright © 2007, 2006, 2004 New Age International (P) Ltd., Publishers
Published by New Age International (P) Ltd., Publishers

All rights reserved.

No part of this ebook may be reproduced in any form, by photostat, microfilm, xerography, or any other means, or incorporated into any information retrieval system, electronic or mechanical, without the written permission of the publisher. *All inquiries should be emailed to rights@newagepublishers.com*

ISBN (13) : 978-81-224-2947-3

PUBLISHING FOR ONE WORLD

NEW AGE INTERNATIONAL (P) LIMITED, PUBLISHERS

4835/24, Ansari Road, Daryaganj, New Delhi - 110002

Visit us at www.newagepublishers.com

To

My mother, who taught me how to hold pen in my little fingers.

My father, who taught me modesty and tolerance.

My wife, a symbol of mutual trust and mutual respect.

My daughter and son, who exhibited a high degree of patience.

My students, who made me learn the subject.

The Almighty, who has created such a beautiful world.

© Apprise Education, Reprise Innovations ©

**This page
intentionally left
blank**

www.EasyEngineering.net
ENGINEERING
© Apprise Education, Reprise Innovations ©

| PREFACE TO THE FOURTH EDITION |

In the fourth edition of **Basic Electrical Engineering**, two more chapters have been added.

Chapter i on DC circuits explains the International System of Units and gives clear concepts of electrical circuits, current, voltage or potential, resistance, power and energy. Also, Ohm's law and Kirchoff's laws have been explained with a solution of series and parallel circuits using these laws.

Chapter ii on electromagnetic induction explains Faraday's laws of electromagnetic induction and Lenz's law. Laws of electromagnetic forces, dynamically and statically induced e.m.f.'s have also been explained. Further, concepts of mutual and self-inductances, and hysteresis losses and eddy current losses have been discussed.

Under AC circuits, in chapter 1, the concepts of leakage flux, fringing flux, magnetostatic potential, m.m.f. and reluctance have been included.

With these additions, the utility of this book has been greatly enhanced.

Any constructive suggestion for further improvement of this book will be gratefully acknowledged.

C.L. Wadhwa

**This page
intentionally left
blank**

www.EasyEngineering.net
ENGINEERING
© Apprise Education, Reprise Innovations ©

| PREFACE TO THE FIRST EDITION |

Electrical Engineering has been written as a core course for all engineering students viz. Electronics and Communication, Computer Engineering, Civil, Mechanical Engineering etc. With advancement in technologies in almost all spheres of engineering, it is becoming difficult to provide more than one slot for interdisciplinary courses. However, the author feels that no engineering can work without electric energy. The basic input to all engineering is the electric energy. A basic course on Electrical Engineering is almost essential for all engineering students. Keeping this compulsion in mind and also that this course will normally be offered at the first year level of engineering, the author has made modest effort to give in a concise form various features of Electrical Engineering starting from simple ac circuits to Network theorems, measuring instruments, transformers, various dc and ac machines including stepper motor. Various physical phenomenon have been explained using simple language avoiding the rigorous of mathematics.

Chapter I deals with the steady state analysis of a.c. series and parallel circuits and series and parallel resonance.

Chapter II describes various network theorems, star-delta transformation and methods of mesh and nodal analysis for dc networks.

Balanced and unbalanced, three phase circuits have been analysed and methods of 3-phase power measurements have been discussed in Chapter III.

Measuring instruments like, ammeter, voltmeter, wattmeter and energy meter have been described in chapter IV.

Transformer is a very important electrical equipment. The construction, principle of operation, parameter calculations, efficiency and regulation of transformer have been discussed in chapter V.

Chapter VI deals in types of dc machines, their operation and characteristics, efficiency and speed control and application of these machines.

Chapter VII deals into the construction, principle of operation and applications of three phase synchronous motors and stepper motor.

Three phase induction motors form almost 60 to 70% of the total load on power system. These motors have been discussed in chapter VIII including types, construction, principle of operation, methods of starting, torque-slip characteristic, application and single phasing operation. Single phase induction motors find wide application in Office and domestic appliances. Construction, principle of operation and application of these motors have been described in chapter IX.

Power systems is the most capital intensive and the most complex system ever developed by man. Chapter X gives in brief, various supply and distribution systems and suggests methods for improvement of power factor.

x

A large number of problems have been solved to help understand the theory. At the end of each chapter unsolved problems with their answers have been suggested for further practice. At the end, a large number of objective type questions have been added to help the reader to test himself.

Any constructive suggestion for the improvement of the book will be gratefully acknowledged.

Last but not the least, I wish to express my gratitude to my wife Usha, daughter Meenu and son Sandeep for their patience and encouragement during the preparation of the book.

—C.L. Wadhwa



| CONTENTS |

	<i>Preface to the Fourth Edition</i>	(vii)
	<i>Preface to the First Edition</i>	(ix)
i	DC CIRCUITS	1
i.1	International System of Units	1
i.2	Circuit	3
i.3	Electric Current	3
i.4	Electric Potential	4
i.5	Resistance	6
i.5.1	Conductivity and Conductance	7
i.6	Power	8
i.7	Energy	8
i.8	Ohm's Law	8
i.9	Kirchhoff's Laws	11
i.10	Series Circuits	13
i.10.1	Parallel Circuits	15
i.10.2	Series Parallel Circuits	18
ii	ELECTROMAGNETIC INDUCTION	29
ii.1	Introduction	29
ii.2	Faraday's Laws of Electromagnetic Induction	29
ii.3	Lenz's Law	30
ii.4	Laws of Electromagnetic Forces	30
ii.4.1	Fleming's Left Hand Rule	32
ii.4.2	Fleming's Right Hand Rule	33
ii.5	Dynamically Induced EMF (Generator or Motional EMF)	33
ii.5.1	Statically Induced EMF or Transformer EMF	34
ii.6	Self Inductance	35
ii.7	Mutual Inductance	36
ii.8	Hysteresis Loss	38
ii.9	Eddy Current Loss	40
1	A.C. CIRCUITS	49
1.1	Introduction	49
1.2	Phase	51
1.3	The Average Value of a Waveform	52
1.4	The Effective or RMS Value of a Wave	54

1.4.1	Form Factor	55
1.4.2	Peak Factor or Crest Factor	56
1.5	Phasor Diagram	56
1.5.1	Phasor Algebra	57
1.6	Resistance Connected Across a Sinusoidal Voltage	57
1.6.1	Inductor Across Sinusoidal Source	58
1.6.2	Capacitor Connected Across Sinusoidal Source	59
1.6.3	Series R-L Circuit Connected to Sinusoidal Source	60
1.6.4	RC Series Circuit Connected to Sinusoidal Source	61
1.6.5	R-L-C Series Circuit Connected to Sinusoidal Source	64
1.7	Parallel R-L Circuit Across Sinusoidal Supply	66
1.7.1	Parallel R-C Circuit Across Sinusoidal Source	67
1.7.2	Series Parallel Circuits of R, L and C	68
1.8	Resonance	69
1.9	Series Resonance	70
1.9.1	Quality Factor Q	74
1.10	Parallel Resonance	80
1.10.1	Q of Parallel RLC Circuit	85
1.11	Magnetic Circuits	91
1.11.1	Analyses between Magnetic and Electric Circuits	92
1.11.2	Leakage Flux	98
1.11.3	Fringing of Flux	99
1.12	Dot Convention for Coupled Circuits	102
2	NETWORK THEORY	119
2.1	Introduction	119
2.2	Kirchhoff's Laws	119
2.3	Star-Delta Transformation	122
2.4	Loop Analysis	125
2.5	Nodal Analysis	130
2.6	Superposition Theorem	134
2.7	Thevenin's Theorem	136
2.8	Norton's Theorem	140
2.9	Maximum Power Transfer Theorem	144
3	THREE PHASE SUPPLY	160
3.1	Three Phase Circuits	160
3.2	Analysis of Star Circuits	164
3.3	Delta Circuits	169
3.4	Measurement of Power in 3-Phase Circuits	172

3.4.1	Three Wattmeter Method	172
3.4.2	Two Wattmeter Method	173
3.4.3	One Wattmeter Method	175
3.5	Measurement of Reactive Power	176
4	BASIC INSTRUMENTS	181
4.1	Introduction	181
4.2	Types of Instruments	181
4.2.1	Permanent Magnet Moving Coil Type	182
4.2.2	Dynamometer Type Moving Coil Instruments	183
4.3	Moving Iron Type	185
4.4	Induction Instruments	186
4.4.1	Induction Disc Type or Shaded Pole Type	186
4.4.2	Induction Cylinder Type Instrument	188
4.4.3	The Shunt	188
4.4.4	High Series Resistance (Voltage Indicating Instrument)	189
4.5	Wattmeter	192
4.6	Methods of Connection in the Circuit	195
4.7	Energy Meters	196
4.7.1	Single Phase Induction Type Energy Meter	196
4.7.2	Creep	198
4.7.3	Friction Compensation	198
4.7.4	Meter Phase Angle Error	199
4.8	Polyphase Induction Watt Hour Meters	199
4.9	Phantom or Fictitious Load	200
5	TRANSFORMER	203
5.1	Introduction	203
5.2	Construction	204
5.3	EMF Equation of a Transformer	205
5.4	No Load Operation	206
5.5	Operation of Transformer Under Load Condition	208
5.6	Equivalent Circuit	210
5.7	No Load or Open Circuit Test	214
5.8	Short-Circuit Test	215
5.9	Voltage Regulation	217
5.10	Losses in a Transformer	221
5.11	Efficiency of Transformer	222
5.12	Polarity of a Transformer	228
5.13	Testing of Transformers	231

5.13.1	Sumpner's Test	231
5.14	Auto Transformer	232
5.14.1	Saving in Copper in Auto Transformer	234
6	D.C. MACHINES	245
6.1	Introduction	245
6.2	Construction.....	245
6.3	EMF Equations	247
6.3.1	Armature Reaction	248
6.3.2	Commutation	251
6.4	Classification of DC Machines	253
6.5	Magnetisation Characteristics	256
6.6	Terminal Characteristic of Shunt Generator	257
6.6.1	Series Generator Characteristic	257
6.6.2	Load Characteristics of Compound Generator	258
6.7	DC Motors	261
6.7.1	DC Shunt Motor	261
6.7.2	DC Series Motor	263
6.7.3	DC Motor Starter	264
6.8	Losses in DC Machines	265
6.9	Efficiency of DC Machines	266
6.10	Swinburne Test	268
7	THREE-PHASE SYNCHRONOUS MACHINES	276
7.1	Introduction	276
7.2	Construction.....	276
7.2.1	EMF Equation.....	277
7.2.2	Rotating Magnetic Field	280
7.2.3	Armature Reaction	283
7.2.4	Open Circuit and Short Circuit Tests on Alternator	284
7.2.5	Voltage Regulation	286
7.2.6	Losses and Efficiency	287
7.2.7	Magnetic Poles in Machines	288
7.2.8	Steady State Operation	288
7.2.9	Power and Torque.....	289
7.3	Effect of Excitation on Armature Current	291
7.4	Change of Load	292
7.5	Starting of Synchronous Motor	292
7.5.1	Damper Winding Starting	292
7.5.2	Auxiliary Motor Starting	293
7.6	Speed Torque Characteristic	294

7.7	Synchronous Condenser	294
7.8	Applications	296
7.9	Stepper Motor	299
7.9.1	Permanent Magnet Type	299
7.9.2	Comparison of Stepper Motors	302
7.9.3	Application	302
8	THREE-PHASE INDUCTION MOTORS	304
8.1	Introduction	304
8.2	Construction	304
8.3	Principles of Operation	305
8.4	EMF and Current Relations	306
8.5	Mechanical Power Developed	308
8.6	Starting of 3-Phase Induction Motors	315
8.7	Industrial Application	325
9	SINGLE PHASE INDUCTION MOTORS	328
9.1	Introduction	328
9.2	Principle of Operation	329
9.3	Starting of Single Phase Induction Motors	331
9.4	Application	335
9.5	Universal Motor	335
9.6	Synchros	337
9.7	DC Tachometer	338
9.8	AC Tachometer	338
9.9	Two Phase Servomotor	339
10	POWER SYSTEM	342
10.1	Introduction	342
10.2	Types of Distribution System	343
10.2.1	The Radial Systems	343
10.2.2	The Ring Mains Systems	344
10.3	Cost Comparison of Supply Systems	344
10.4	Power Factor Improvement	347
10.4.1	Causes of Low p.f.	349
10.4.2	Methods to Improve p.f.	349
10.5	Generation—Non-Conventional Sources	352
10.5.1	Tidal Power	353
10.5.2	Wind Power	353
10.5.3	Geothermal Power	354
10.5.4	Wave Power	355

10.5.5	Magneto Hydro Dynamic (MHD) Generation	356
10.5.6	Solar Energy	356
10.6	Conventional Sources	357
10.6.1	Hydro Station	357
10.6.2	Steam Power Plant.....	358
10.6.3	Nuclear Power Plant	358
10.6.4	The Gas Turbine Plant	358
11	DOMESTIC WIRING	361
11.1	Introduction	361
11.2	Types of Domestic Wiring	361
11.2.1	Cleat Wiring	361
11.2.2	Wooden/PVC Casing and Capping Wiring	362
11.2.3	Toughened Rubber Sheath (TRS or CTS) or Batton Wiring	363
11.2.4	Conduit Wiring	363
11.3	Specifications of Wires	364
11.3.1	Size of Conductor	365
11.4	Distribution Board	367
11.5	Types of Cables	368
11.6	Lighting Control Circuits.....	368
11.7	Earthing System.....	370
11.8	Fuses and HRC Fuses	372
11.8.1	Calculation of Fuse Rating	377
	MULTIPLE CHOICE QUESTIONS	379
	REFERENCE	401
	INDEX	403

CHAPTER

i **DC Circuits****i.1 INTERNATIONAL SYSTEM OF UNITS**

The international system of units abbreviated as SI has been universally accepted for international use in all fields of engineering and day to day requirements. Therefore, all business and even household transactions are conducted in SI units. SI system offers the following advantages over other system of units.

1. There is one and only one unit for each physical quantity. Therefore, a table of conversions from one unit to another is not required.
2. The system is coherent with the derived units. The conversion factor from the original unit to the derived unit is simply a multiplication or division by 1.
3. There are no conversions between electrical and mechanical systems *e.g.* a motor or an automobile engine is now rated as in kW rather than horse power. Energy is now expressed in watt-sec rather than in Joule etc.

There are a large number of quantities (more than thirty) which an electrical engineer deals in. However it is not necessary to assign a standard unit to each quantity as these quantities are functionally related through experiments, mathematical derivation or definitions. The minimum number of quantities required to express the units of all other quantities are known as fundamental quantities. The following are the considerations for selection of fundamental quantities.

- (i) A minimum number of constant should be required to establish relationship between the various quantities involved in the study of the given discipline.
- (ii) The measuring units shall be of a practical size.

There are seven fundamental units which are listed below with their name, quantity symbol and unit symbol.

1. Length—metre, *l*, *m*
It is defined in terms of wavelengths of a particular radiation from krypton 86.
2. Mass—kilogram, *m* kg
It is defined equal to the mass of the international prototype kept in Sevres, France.
3. Time—seconds, *t*, *s*
It is defined in terms of the duration of a specific number of periods of a particular radiation from the cesium-133 atom.
4. Current—ampere, *I*, *A*
It is defined as the constant electric current in two infinite parallel conductors separated from each other by 1 m, produce a force of 2×10^{-9} N/m.

5. Temperature—Kelvin, T, K

It is defined as the fraction $\frac{1}{273.16}$ of the thermodynamic temperature of water at which point it is simultaneously a gas, a liquid and a solid (the trip point).

6. Quantity—mol, mol

It is defined as the amount of substance which contains as many elementary particles as there are atoms in 0.012 kg of carbon 12.

7. Light—Candela, I, Cd

It is defined as the light intensity of the freezing point of platinum under specified conditions.

The supplementary units used for two and three dimensional problem related to geometry are :

1. Phase angle, radian rad
2. Solid angle, Steradian Sr

At serial no. 4 we have taken current as the fundamental quantity. However, from a purely theoretical consideration the fourth fundamental quantity could be taken as charge which has the fundamental unit coulomb. It is possible to derive current from charge and vice versa. However, the reason for selection of current rather than charge as the fundamental quantity is that ampere serves as the link between electrical, magnetic and mechanical quantities and is more readily measured.

Even though it is possible to function with the seven fundamental units mentioned above, yet if a set of derived units are defined with special names, the resulting equations and calculations are greatly simplified Table i.1 lists the Derived units in S.I.

Table i.1 SI Derived units

<i>Unit</i>	<i>Name</i>	<i>Quantity Symbol</i>	<i>Unit Symbol</i>	<i>Expression in Terms of Other Units</i>
1. Absorbed dose	gray		Gy	J/kg
2. Activity	becquerel		Bq	s ⁻¹
3. Electric capacitance	farad	<i>C</i>	F	C/V
4. Electric conductance	siemens	<i>G</i>	S	A/V
5. Electric inductance	henry	<i>L</i>	H	Wb/A
6. Electric potential difference	volt	<i>V, E</i>	V	W/A
7. Electric resistance	ohm	<i>R</i>	Ω	V/A
8. Energy	joule	<i>W</i>	J	N.m
9. Force	newton	<i>F</i>	N	kg.m/s ²
10. Frequency	hertz	<i>f</i>	Hz	s ⁻¹

11. Illuminance	lux	E	lx	lm/m^2
12. Luminous flux	lumen	ϕ	lm	cd.sr
13. Magnetic flux	weber	ϕ	Wb	V.s
14. Magnetic flux density	tesla	B	T	Wb/m^2
15. Power	watt	P	W	J/s
16. Pressure; stress	pascal	p	Pa	N/m^2
17. Quantity of electricity	coulomb	Q	C	A.s

i.2 CIRCUIT

An electric circuit is a closed path consisting of active and passive elements all interconnected and the current flow is confined to the closed path. Fig. i.1 shows a typical circuit consisting of one active and two passive elements. An active element is one which supplies energy to the circuit where as a passive element is one which receives energy and then this energy is converted into heat (resistor) or stores it in an electric (capacitor) or magnetic field (inductor). The battery is the active element in Fig. i.1.

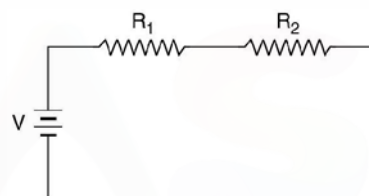

Fig. i.1 Electric circuit.

i.3 ELECTRIC CURRENT

The concept of charge is based on atomic theory. An atom has positive charges (protons) in its nucleus and an equal number of electrons (negative charges) surround the nucleus making the atom neutral. Removal of an electron leaves the atom positive charged and addition of an electron makes the atom negatively charged. The basic unit of charge is the charge on an electron. The mks unit of charge is coulomb. An electron has a charge of 1.062×10^{-19} C.

When a charge is transferred from one point in the circuit to another point it constitutes what is known as electric current. An electric current is defined as the time rate of flow of charge through a certain section. Its unit is ampere. A current is said to be of one ampere when a charge of 1 coulomb flows through a section per second.

Mathematically,

$$i = \frac{dq}{dt} \quad (\text{i.1})$$

If charge q is expressed in coulomb and time in second, 1 amp flow of current through a section is equivalent to approx. flow of 6.24×10^{18} electrons per second through the section.

Yet another method of defining electric current (1 amp) is as the constant electric current in two infinite parallel conductors separated from each other by 1 m, experience a force of 2×10^{-9} N/m.

i.4 ELECTRIC POTENTIAL

Law of conservation of energy states that energy can neither be created nor destroyed. However, its form can be converted *i.e.*, energy can be converted from one form of energy to another *e.g.* Electromechanical energy conversion, Electro-chemical energy conversion, MHD energy conversion, photoelectric energy conversion etc. In all these cases the function of each of these sources of electric energy is the same in terms of energy and charge *i.e.*, the energy is spent as work for transporting charge from one point to another in a circuit. The movement of charges contribute to current and the amount of work done per unit charge is the potential difference between the two points. The electronic charges flow from a lower potential to a higher potential and these contribute to electronic current, whereas the conventional current is considered to flow from higher potential to lower potential.

If a differential charge dq is given a differential energy dw , the rise in potential of the charge

$$v = \frac{dw}{dq} \quad (\text{i.2})$$

The units of potential or potential difference as derived from equation are joule/coulomb or $\frac{\text{Watt sec}}{\text{Amp. sec}}$ or $\frac{\text{Watt}}{\text{Amp.}}$ and usually is termed as volts.

We have defined electric potential in terms of electronic charge flow. However we can also explain with reference to static charges, considering electric field due to such charge. Suppose we have a point charge Q in space located at some point. The very presence of this charge gives rise to an electric field emanating radially from this charge in all directions, as shown in Fig. i.2. The strength of the electric field decreases as we move away from the charge Q which practically reduces to zero at infinity. If we move a differential charge dq from ∞ towards the charge Q , the differential charge experiences a force of repulsion or attraction depending upon whether the two charges Q and dq are of same polarity or opposite polarity respectively. Suppose Q and dq are positively charged. If we bring charge from infinity to point r_1 from Q , the force experienced by the charge dq according to Coulomb's law is given as

$$dF = \frac{Q \cdot dq}{4\pi\epsilon_0 r_1^2}$$

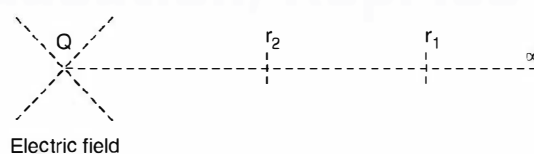

Fig. i.2 Defining potential with respect to electric field (static charges).

or in general if the distance is r from the charge Q the force experienced by the charge dq is

$$dF = \frac{Q dq}{4\pi\epsilon_0 r^2} \bar{a}_r$$

where \bar{a}_r is a unit vector along the line joining Q and dq and indicates the direction of force. Now if this differential charge is moved through a distances dr , the workdone on dq against the electric field is

$$dW = dF \cdot dr = \frac{Q dq}{4\pi\epsilon_0 r^2} dr$$

or the total work done against the electric field by moving the charge from infinity to r is

$$W = \int_{\infty}^r \frac{Q dq}{4\pi\epsilon_0 r^2} dr = \frac{Q dq}{4\pi\epsilon_0 r}$$

or the work done divided by dq is

$$\frac{W}{dq} = \frac{Q}{4\pi\epsilon r} = \text{volt} = \text{potential}$$

i.e. by moving the charge, there is rise in its potential from zero to the value given above.

In fact by definition potential at any point r from the charge Q , due to charge Q is the work done against the electric field when a charge of one coulomb is moved from infinity to that point. However, in our explanation we have not taken the test charge as unit charge but a differential $dq \ll Q$ so that when we bring test charge in the electric field set up by charge (Q) if the electric field is not disturbed and that is the basic requirement of any measurement *i.e.* any device that is used for measurement of some quantity in a circuit, should not disturb the quantity we are suppose to measure.

However, we defined potential at a point due to a charge distribution is the work done per unit charge when it is moved from infinity to that point.

Dimensionally

$$\frac{W}{dq} = \frac{W}{It}$$

Also from Table i.1 the derived unit for power (P) is the watts such that

$$P = \frac{W}{t}$$

Hence $\frac{W}{dq} = \frac{W}{It} = \frac{P}{I} = \text{V the volts}$

To find potential difference between two points say r_1 and r_2 , we get

$$\frac{Q}{4\pi\epsilon} \left[\frac{1}{r_2} - \frac{1}{r_1} \right]$$

where r_2 and r_1 are measured from the charge Q . It is to be noted that when a unit charge moves from a point of higher potential (closer to Q in this case) to a point of lower potential (relatively farther from Q) it gives up energy. However, when a unit charge moves from a point of lower potential to one of higher potential, it receives energy. In the former case the potential difference is known as voltage drop whereas in the latter case the voltage rise.

If potential is multiplied by the current $\frac{dq}{dt}$

$$v \times i = \frac{dw}{dq} \times \frac{dq}{dt} = p \quad (\text{i.3})$$

which gives rate of change of energy with time and is equal to power.

Thus, power $p = v \times i$

Since $p = \frac{dw}{dt}$.

Example i.1. A person receives a severe shock when he is subjected to a current of 25 mA for a time duration of 30 ms. How many electrons pass through the person.

Solution. $Q = It = 25 \times 10^{-3} \times 30 \times 10^{-3} = 75 \times 10^{-5} \text{ C}$

Since $1 \text{ C} = 6.242 \times 10^{18} \text{ electron}$

Hence no. of electron $= 75 \times 6.242 \times 10^{13}$
 $= 4.68 \times 10^{15} \text{ Ans.}$

Example i.2. A lightning discharge between clouds during a thunder storm is of 20 C. The time of the discharge is 10 m sec. Determine the average lightning current.

Solution. $I = \frac{q}{t} = \frac{20}{10 \times 10^{-3}} = 2 \text{ kA Ans.}$

Example i.3. A device stores 500 J of energy and releases this energy in the form of an electric current of 40 A which has a duration of 15 m sec. Determine the average voltage across the terminals of the device.

Solution. Since Energy $W = VIt$
 $500 = V \times 40 \times 15 \times 10^{-3}$

or $V = \frac{500}{40 \times 15 \times 10^{-3}} = 833 \text{ volts Ans.}$

i.5 RESISTANCE

We know that a random motion of free electrons results from the exchange of the outer orbit between the atoms. In order to establish a net or average flow of electrons in one direction an external force is necessary. This force is necessary to overcome a *resistance*. If the material is a good conductor of electric charges, relatively smaller force is required to produce a current flow. Copper and silver are good conductors. Silver is better conductor than copper.

A good insulator is one which effectively eliminates the flow of current of any practical magnitude. Polystyrene is a good insulator and has approximately 3×10^{18} free electrons per cubic metre. Materials which have 10^{21} to 10^{25} free electrons per cubic metre are known as semiconductors.

From Table i.1 it is found that the derived units for resistance is ohm, its quantity symbol is R and the unit symbol is Ω . The unit for electric resistance is defined as

$$R = \frac{V}{I} \left(r = \frac{V}{A} \right)$$

If the potential difference between point a and b is say 1 V when the current in the circuit is 1 A, the resistance between points a and b is said to be of 1 Ω .

A circuit element designed to have property of resistances is known as a resistor and its circuit symbol is shown in Fig. i.3. The resistors normally are in the form of wires.



Fig. i.3 Circuit symbol of a resistor.

Experimental evidence shows that the value of resistances R of a conductor is directly proportional to its lengths

$$i.e. \quad R \propto l$$

Also, if the cross sectional area of the cylindrical wire is varied, the resistance is found to be inversely proportional to the cross-sectional area A i.e. $R \propto \frac{1}{A}$

These two proportions can be combined and we have

$$R \propto \frac{l}{A}$$

and by using a constant of proportionality ρ the proportion becomes the equation and

$$R = \rho \frac{l}{A} \Omega$$

In order to find the units for ρ we substitute the units of other quantities

$$\text{Ohm} = \rho \frac{\text{length}}{\text{Area}} = \rho \frac{\text{metre}}{\text{metre}^2}$$

or

$$\rho = \text{Ohm-metre}$$

Thus ρ , the resistivity of the material or specific resistance is the resistance of a cube of material measured between opposite faces. The edge of the cube is 1 m. It is to be noted that if specific resistance is given in ohm-m, the length of the wire must be taken in metres and area of cross-section in sq. meters.

Example i.4. Determine the resistance of a 1-km strip of copper of rectangular cross-section 2.5 cm by 0.05 cm. Assume $\rho = 1.724 \times 10^{-8} \Omega \cdot \text{m}$.

Solution. Using the formula for resistance and substituting various quantities with suitable units we have

$$\begin{aligned} R &= \rho \cdot \frac{l}{A} = 1.724 \times 10^{-8} \frac{1000}{2.5 \times 0.05 \times 10^{-4}} \\ &= 13.8 \times 10^{-1} = 1.38 \Omega \text{ Ans.} \end{aligned}$$

Sometimes the diameter of the conductor is given in terms of circular mils (CM) where 1000 mils = 1 inch.

i.5.1 Conductivity and Conductance

The specific resistance or resistivity ρ of a material represents its opposition to the flow of electric current. However the reciprocal of ρ represents a unit describing the material in terms of its ease to allow flow of electric current. $\gamma = \frac{1}{\rho}$ known as the conductivity of the material.

Similarly, the reciprocal of resistance R is the conductance G i.e. $G = 1/R$.

The SI derived units for conductance from Table i.1 is the Siemens. The quantity symbol is G and the unit symbol is S. The Siemens is derived as $G = \frac{A}{V}$, S, where A is amperes.

Earlier conductance was given in mho and its symbol $\overline{\Omega}$. However, the use of unit mho must be avoided and Siemens only should be used.

Now
$$R = \frac{1}{G} = \frac{1}{\gamma} \frac{l}{A} = \frac{l}{\gamma A} \Omega$$

or
$$G = \frac{\gamma A}{l} s$$

It is to be noted that resistance of a conductor increases with increase in temperature. If R_1 is the resistance of a conductor at T_1 and R_0 at T_0 and coefficient of resistance at T_0 is say α_0 , then these quantities are related as

$$R_1 = R_0 + \alpha_0 (T_1 - T_0)R_0 = R_0 [1 + \alpha_0(T_1 - T_0)]$$

Whenever an incandescent bulb is switch in to electric supply, its cold resistance being smaller, it draws large current at the beginning and with time as the filament gets heated its temperature increases gradually and then the current decreases gradually and finally a particular temperature of the filament is reached when there is no further increase in resistance, the current also attains a fixed value. The resistance temperature coefficient for copper is 0.00426 ohm/ $^{\circ}$ C/ohm at 0 $^{\circ}$ C.

i.6 POWER

If potential is multiplied by current $\frac{dq}{dt}$, we have

$$V \times I = \frac{dW}{dq} \times \frac{dq}{dt} = \frac{dW}{dt} = P$$

which gives rate of change of energy with time and is equal to power. The SI derived unit for power (P) is watt expressed as Joule per sec.

i.7 ENERGY

From the previous section we have

$$P = \frac{dW}{dt}$$

or
$$dW = P dt = VI dt$$

or
$$W = \int VI dt$$

and energy of a device is defined as the capacity of doing the work and its derived unit is watts-sec.

i.8 OHM'S LAW

Simon Ohm a german physicist investigated the relation between current and voltage in a resistor and published his experimental results in 1827. The experimental set up is shown in Fig. i.4.

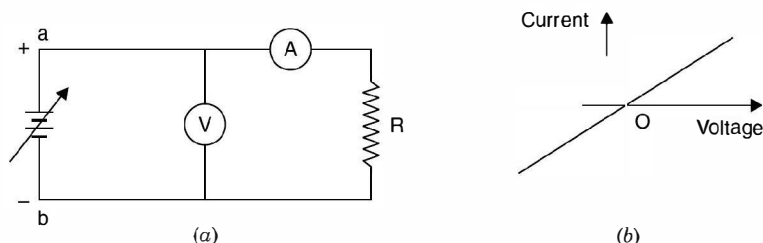

Fig. i.4 (a) Experimental set-up (b) results.

A d.c. variable supply voltage is connected with positive terminal at point *a* and negative terminal at '*b*' as shown. As voltage is increased, the current recorded by the ammeter increases. For every voltage value the current is recorded and the corresponding point is plotted on the rectangular graph. With this a straight line graph passing through origin is obtained in first quadrant. Next the terminals of the variable dc supply are interchanged *i.e.* *a* is connected to $-ve$ polarity of dc supply and *b* is connected to $+ve$ polarity of dc supply. Since both the voltmeter and ammeter are moving coil, their individual connection should also be interchanged so that meters can read up scale. This has been done to reverse the direction of flow of current through the resistor *R*. Again the voltage is varied and corresponding to each voltage, current is recorded and the pairs of *V* and *I* are plotted in the third quadrant.

The experimental results indicate that there is a linear relationship between the current and voltage both in the first and third quadrant. The slope of straight line is also same in both the quadrants which shows that the potential difference across the terminals of the conductor is proportional to the current passing through it *i.e.* $V \propto I$.

Also it is found that for a constant current in the conductor resistance should be changed proportional to the potential difference *i.e.* $V \propto R$.

Combining the two proportionalities, we have

$$V \propto IR$$

or

$$V = kIR$$

where *k* is a constant of proportionality. However, the units of voltage, current and resistance are defined so that the value of $k = 1$. When the current is 1 amp, voltage 1 volt, the resistance is 1 Ω .

$$1 = k \cdot 1 \cdot 1$$

Thus the equation becomes

$$V = IR$$

The equation explains ohm's law which is stated as follows :

Physical condition (Temperature, Pressure etc.) of the conductor remaining constant, the voltage across the terminals of a conductor is proportional to the current flowing through it.

The resistances which Ohm considered are linear *i.e.* the resistances which have linear *V-I* characteristic. Also, these are bilateral *i.e.* irrespective of direction of flow of current the resistance does not change.

There are some non-linear resistance derives also *e.g.* in electronic, a diode or a triode and many such devices have minimum resistance when these are forward biased and when reversed biased these offer very high resistance. Some of the non-linear resistance *V-I* characteristics are shown in Fig. i.5.

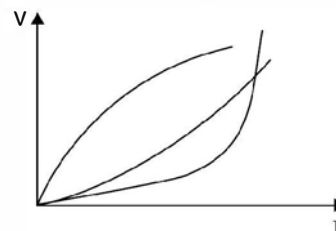

Fig. i.5 Non linear resistances.

A resistance is always rated in terms of its ohm's value and current rating or wattage rating. Usually resistances used in electronic circuitry use wattage and ohmic ratings.

Two basic applications of a resistance are shown in Fig. i.6. In Fig. i.6 (a) it is being used as a potential divider in d.c. circuit. Here we want dc voltage variable from a fixed supply voltage.

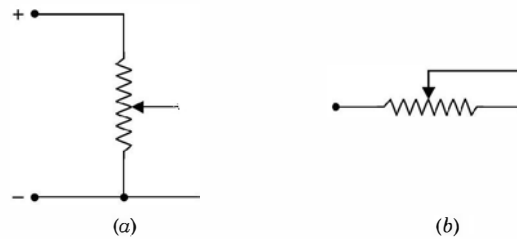

Fig. i.6 (a) Potential divider (b) Current limiter.

In Fig. i.6 (b) it is used as a current limiting device and is inserted in series with the circuit where the current is to be limited. When used for current limitation, it is known as rheostat.

The expression for power dissipated in a resistor R is derived as follows :

We know that

$$P = VI$$

Using one version of ohms law *i.e.* $V = IR$

$$P = (IR) I = I^2R \text{ watts}$$

Again using second version of ohms law $I = \frac{V}{R}$

$$P = V \cdot \frac{V}{R} = \frac{V^2}{R} \text{ watts.}$$

It is to be noted that V is the voltage across the resistance R and not the supply voltage. Depending upon the situation one of these formulae can be used.

Example i.5. The load resistance in a 220 V circuit is 80 ohms. Determine the load current.

Solution. Using ohm's law

$$I = \frac{V}{R} = \frac{220}{80} = 2.75 \text{ A Ans.}$$

Example i.6. Determine the conductance of a short circuit on 120 volt which results in a short circuit current of 500 A.

Solution. Since $G = \frac{I}{V} = \frac{500}{120} = 4.16 \text{ S.}$

Example i.7. Determine the power rating of a device which is rated at 15 A 250 Volts.

Solution. $P = VI = 250 \times 15 = 3750 \text{ watts.}$

Example i.8. A resistor is rated for 10 kΩ 1 watt. Determine its maximum voltage and current ratings.

Solution.
$$P = \frac{V^2}{R} = 1 = \frac{V^2}{10,000}$$

or $V^2 = 10,000$

or $V = 100$ volts **Ans.**

Similarly to calculate maximum current rating

$$P = I^2 R = 1 = I^2 \cdot 10,000$$

or $I = \frac{1}{100} = 0.01$ A or 10 mA.

Example i.9. An electric motor operating from 220 volts supply takes a current of 8 A. The motor has an efficiency of 80%. Determine the output of the motor.

Solution. Power input to the motor

$$P = VI = 220 \times 8 = 1760 \text{ watts.}$$

Since the efficiency of the motor is 80%, 80% of input will be the output *i.e.*

$$\begin{aligned} \text{Power output} &= \text{Power input} \times \text{efficiency} \\ &= 1760 \times 0.8 = 1408 \text{ watts } \mathbf{Ans.} \end{aligned}$$

i.9 KIRCHHOFF'S LAWS

Kirchhoff's postulated two basic laws way back in 1845 which are used for writing network equations. These laws concern the algebraic sum of voltages around a loop and currents entering or leaving a node. The word algebraic is used to indicate that summation is carried out taking into account the polarities of voltages and direction of currents. While traversing a loop we will take voltage drops as positive and voltage rises as negative. Also while considering currents at a node, the currents entering the node will be taken as positive and those leaving would be taken as negative.

Kirchhoff's voltage law usually abbreviated as KVL is stated as follows :

The algebraic sum of all branch voltages around any closed loop of a network is zero at all instants of time. Alternatively, Kirchhoff's voltage law can be stated in terms of voltage drops and rises as follows. The sum of voltage rises and drops in a closed loop at any instant of time are equal. KVL is a consequence of law of conservation of energy as voltage is energy or work per unit charge. If we start from one node in a loop and move along the closed loop and come back to the same node, obviously the total potential difference or sum of potential rises must equal the total sum of potential falls. Just as, if we start from one point on the surface of the earth and after travelling through valleys and hills come back to the same point, the total displacement is zero. We talk elevation's and depression on the earth with respect to the sea level. Similarly, in case of voltages we take ground as the reference which is shown in Fig. i.7(a). Here potential of node A is above the ground and that of B is below the ground potential.

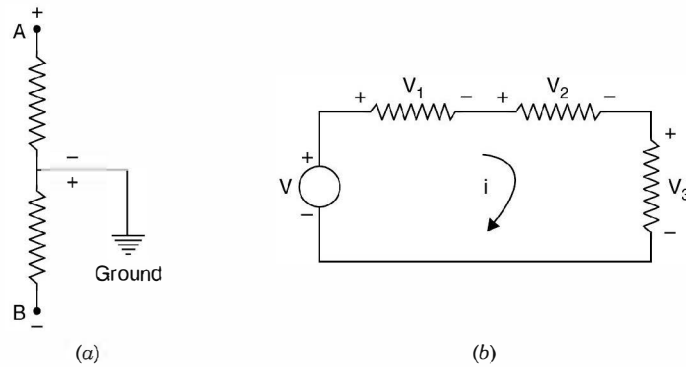

Fig. i.7 (a) Potential reference, (b) KVL application.

We know that electronic current flows from negative potential to positive potential, the conventional current flows from positive potential to negative potential. Therefore, when current i flows in the circuit of Fig. i.7 (b) it produces voltages polarities in various elements as shown in the figure. Applying Kirchhoff's voltage law

$$v_1 + v_2 + v_3 - v = 0$$

Or in terms of voltage drops and voltage rises

$$v_1 + v_2 + v_3 = v$$

Kirchhoff's current law states that the algebraic sum of all currents terminating at a node equals zero at any instant of time. Alternatively, this states that sum of all currents entering a node equals the sum of currents leaving the same node at any instant of time.

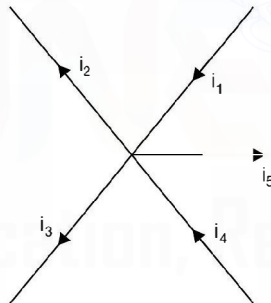

Fig. i.8 One node with terminating branches.

Fig. i.8 shows one node along with various branches terminating in it, in a network and the currents with directions in the various branches are shown by the arrows. Applying Kirchhoff's current law abbreviated by KCL we get

$$i_1 + i_4 - i_2 - i_3 - i_5 = 0$$

or

$$i_1 + i_4 = i_2 + i_3 + i_5$$

KCL is a consequence of law of conservation of charge. The charge that enters a node, must leave that node as it can't be stored there. Since the algebraic sum of charges at a node must be zero, its time derivative must also be zero at any instant of time.

The two basic laws by Kirchhoff's can be applied to solve any network irrespective of its complexity. One typical application could be to find out equivalence between two networks or

given a network in some configurations, how to find its equivalent so that it could be used more conveniently.

By definition, two networks are said to be equivalent at a pair of terminals if the voltage current relationships for the two networks are identical at these terminals. Consider a network having two resistances in series as shown. The objective is to replace it by a single equivalent resistance.

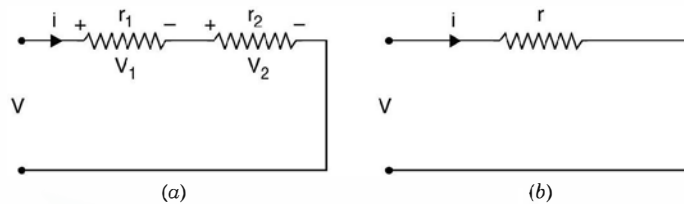

Fig. i.9 (a) Series connection of resistances, (b) Equivalent of (a).

From Fig. i.9 (a), we have

$$v = v_1 + v_2 = ir_1 + ir_2$$

and from Fig. i.9 (b) we have

$$v = ir$$

Therefore,

$$r = r_1 + r_2$$

Similarly if there are n number of resistances in series, the equivalent single resistance would be

$$r = r_1 + r_2 + \dots + r_n$$

i.10 SERIES CIRCUITS

As mentioned under Kirchhoff's law that if there are n resistances R_1, R_2, \dots, R_n connected in series, the total resistance of circuit is

$$R_T = R_1 + R_2 + \dots + R_n$$

and if I is the current in the circuit which will be same through all the resistances as these are connected in series, the voltage drop across various resistances according to ohm's law will be.

IR_1, IR_2, \dots, IR_n and sum of these drops should equal the supply voltage V .

Also, the power loss in various resistors will be $I^2R_1, I^2R_2, \dots, I^2R_n$ and sum total of these power losses must equal I^2R_T when R_T is the total resistance of the series circuit and again this power is also equal to VI where V is the supply voltage.

Example i.10. Three resistances $100 \Omega, 200 \Omega$ and 300Ω are connected in series to a 250 volt supply. Determine the current in the circuit and the power dissipated in each resistor.

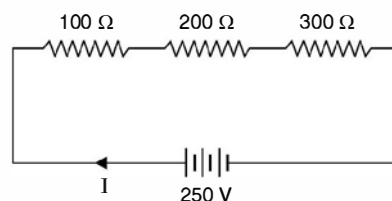

Fig. Ei.10

Solution. The total resistance in the circuit

$$R_T = R_1 + R_2 + R_3 = 100 + 200 + 300 = 600 \Omega$$

$$\text{Current } I = \frac{V}{R_T} = \frac{250}{600} = 0.417 \text{ Amps.}$$

Power loss in 100 Ω resistor = $I^2 R_1 = 0.417^2 \times 100 = 17.36$ watts.

Power loss in 200 Ω resistor = $I^2 R_2 = 0.417^2 \times 200 = 34.72$ watts.

Power loss in 300 Ω resistor = $I^2 R_3 = 0.417^2 \times 300 = 52$ watts.

Total power loss = 104 watts.

However using the formula $P = VI = 250 \times 0.417 = 104.25$ watts

Which is same as the sum total of power consumed in individual resistances. The difference of 0.25 watt is due to round off error.

Example i.11. A 20 Ω resistance is connected in series with an unknown resistance R and the two connected across a 220 volt d.c. supply. The power loss in R is 50 watts. Determine R .

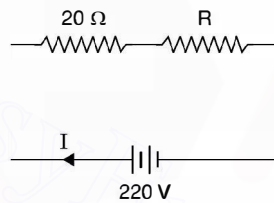

Fig. Ei.11

Solution. The total resistance in the circuit is

$$R_T = 20 + R$$

Hence current in the circuit = $\frac{220}{20 + R} = I$

Power loss in R is $I^2 R = \left(\frac{220}{20 + R}\right)^2 R = 50$

$$220^2 R = (20 + R)^2 \cdot 50$$

$$968 R = R^2 + 40R + 400$$

or $R^2 - 928 R + 400 = 0$

or
$$R = \frac{928 \pm \sqrt{928^2 - 1600}}{2} = \frac{928 \pm 927}{2}$$

$$= 927.5 \Omega \text{ or } 0.5 \Omega$$

Let us find out which one of these a valid result.

Say, we take $R = 0.5 \Omega$

Hence power loss in 0.5 $\Omega = \left(\frac{220}{20.5}\right)^2 \times 0.5 = 57$ watts.

However with $R = 927.5$

$$\text{Power loss} = \left(\frac{220}{947.5} \right)^2 \times 927.5 = 50 \text{ watts}$$

So, $R = 927.5 \Omega$ is more appropriate.

Series resistance as mentioned earlier is used to limit the current in the circuit. Suppose we have an appliance rated for 110 volts. However, the source voltage available is 220 volts. The device can't be connected directly to the supply. Hence a resistance in series with the device is connected and then the combination put across the supply and by adjusting the series resistance 110 volts can be adjusted across the device.

Example i.12. Determine the resistor required to reduce the line voltage from 120 V to 80 volts for the operation of a device. The device is rated at 120 V, 100 watts.

Solution. The resistance of the device is

$$\frac{V^2}{R_d} = 100 = \frac{120^2}{R_d}$$

or
$$R_d = \frac{120^2}{100} = 144 \Omega$$

The current in the device at reduced voltage is $\frac{80}{144} = 0.555 \text{ A}$

The total resistance required to circulate 0.555 A current at full voltage of 120 V is

$$R_T = \frac{120}{0.555} = 216 \Omega$$

Therefore, external resistance required is $216 - 144 = 72 \Omega$ **Ans.**

i.10.1 Parallel Circuits

In a parallel circuit two or more than two resistors are connected to the same source voltage V i.e. the voltage across each resistance is equal to supply voltage. If these are n resistances R_1, R_2, \dots, R_n connected in parallel with the supply, the current through various resistances will be

$$I_1 = \frac{V}{R_1}, I_2 = \frac{V}{R_2}, \dots, I_n = \frac{V}{R_n}$$

and hence the total current in the line or through the source will be sum of these currents i.e.

$$\begin{aligned} I &= I_1 + I_2 + \dots + I_n \\ &= \frac{V}{R_1} + \frac{V}{R_2} + \dots + \frac{V}{R_n} \end{aligned}$$

or
$$\frac{I}{V} = \frac{1}{R_1} + \frac{1}{R_2} + \dots + \frac{1}{R_n}$$

Let
$$\frac{V}{I} = R_{eq}$$

Hence
$$\frac{1}{R_{eq}} = \frac{1}{R_1} + \frac{1}{R_2} + \dots + \frac{1}{R_n}$$

If $R_1 = R_2 = \dots = R_n = R$

Then $\frac{1}{R_{eq}} = \frac{n}{R}$ or $R_{eq} = \frac{R}{n}$

Also since $\frac{1}{R} = G$

Hence $G_{eq} = G_1 + G_2 + \dots + G_n$

It can therefore, be seen that in parallel circuit the equivalent resistance is smaller than the smallest value of branch resistance and line current is greater than the current in any parallel branch.

The main application of parallel circuits is in distribution network. The distribution network works on constant voltage basis *i.e.* irrespective of the power rating, of the device of the devices are connected in parallel. Also, in electronic circuits we sometimes want a certain value of resistance at the output or input terminals and a suitable value of resistor is required that should be connected across terminals to give a particular value of resistance.

Example i.13. Three resistances 750Ω , 600Ω and 200Ω are in parallel. The total current is 1 A . Determine the voltage applied and current in each branch.

Solution. Let V be the supply voltage. The current through various branches are $\frac{V}{750}$, $\frac{V}{600}$ and $\frac{V}{200}$ and sum of these currents is given to be 1 A . Hence

$$1 = V \left[\frac{1}{750} + \frac{1}{600} + \frac{1}{200} \right] = V [0.00133 + 0.00166 + 0.005]$$

$$= V[0.008] \quad \text{or} \quad V = \frac{1}{0.008} = 125 \text{ volts Ans.}$$

Current through each branch $\frac{125}{750} = 0.1666$, $\frac{125}{600} = 0.2083$, $\frac{125}{200} = 0.625$

The sum total is 1 amp .

Example i.14. Two coils are connected in parallel and a voltage of 200 V is applied to the terminals. The total current taken is 25 A and the power dissipated in one of the coils is 1500 W . Determine the resistance of each coil.

Solution.

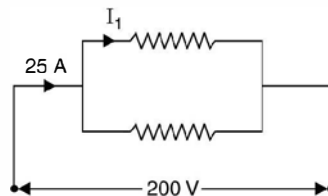

Fig. Ei.14

Since the power taken by one of the coils is 1500 W and voltage applied is 200 V, therefore,

$$1500 = \frac{V^2}{R} = \frac{200 \times 200}{R}$$

or
$$R = \frac{200 \times 200}{1500} = 26.67 \, \Omega \text{ Ans.}$$

Therefore current taken by this coil is

$$I_1 = \frac{200}{26.67} = 7.5 \text{ amp.}$$

Since total current is 25 A, hence current taken by the second branch is $25 - 7.5 = 17.5 \text{ Ans.}$

The resistance of the second branch is

$$R_2 = \frac{200}{17.5} = 11.42 \, \Omega \text{ Ans.}$$

Suppose we are given a parallel combination of two resistances and the total current is given. We are required to find the current distribution in the parallel resistances.

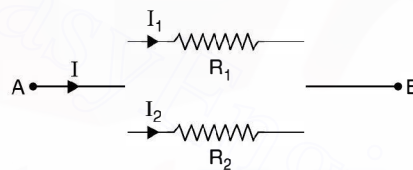

Fig. Ei.14 (a)

Since the voltage across the two branches is same therefore

$$I_1 R_1 = I_2 R_2 \quad \text{or} \quad I_1 = \frac{R_2}{R_1} I_2$$

and
$$I = I_1 + I_2$$

Substituting the value of I_1 in the second equation

$$I = \frac{R_2}{R_1} I_2 + I_2 = I_2 \left(\frac{R_2}{R_1} + 1 \right) = I_2 \cdot \frac{R_1 + R_2}{R_1}$$

or
$$I_2 = I \cdot \frac{R_1}{R_1 + R_2}$$

Similarly
$$I_1 = I \cdot \frac{R_2}{R_1 + R_2}$$

This shows that in a parallel circuit of two resistors, the current in one resistor is the line current times the opposite resistance divided by the sum of the two resistances.

Example i.15. Determine the currents in the parallel branches of the network shown

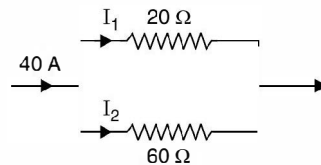

Fig. Ei.15

$$I_1 = 40 \times \frac{60}{20 + 60} = 30 \text{ A}$$

$$I_2 = 40 \times \frac{20}{80} = 10 \text{ A}$$

i.e. the two branches share currents in the inverse ratio of their branch resistances.

Solution. It is to be noted that when two resistances are connected in parallel, the effective resistance of the circuit is

$$R_{eff} = \frac{R_1 R_2}{R_1 + R_2}$$

However, if two conductances are connected in parallel the effective conductance is

$$G_{eff} = G_1 + G_2$$

and if two conductances are connected in series, the effective conductance is $\frac{G_1 G_2}{G_1 + G_2}$.

i.10.2 Series Parallel Circuits

In such circuits we try to reduce the series parallel network into a single resistance using the formulae for reducing a number of series resistances into a single resistance and also reducing parallel resistances into a single equivalent resistance and finally we have one single resistance across a voltage source. Using ohm's law current in this resistance is obtained and then working back we can find out the current in each branch and hence voltage and power dissipated by each resistance.

We illustrate this with the following examples.

Examples i.16. Determine the current through each resistor shown in Fig. Ei.16.

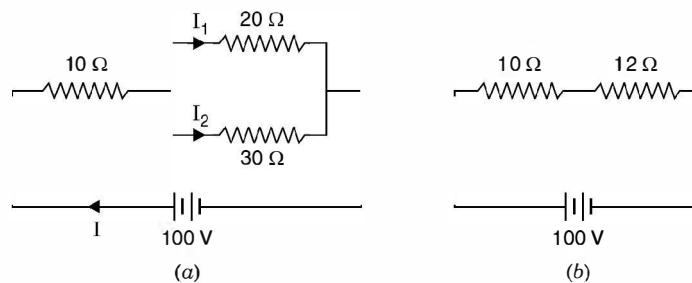

Fig. Ei.16

Solution. There is one series resistance and one parallel combination of two resistances. We first convert parallel combination to a single equivalent using the formula

$$R_{eff} = \frac{R_1 R_2}{R_1 + R_2} = \frac{20 \times 30}{20 + 30} = 12 \Omega$$

Figure (b) gives the new circuit. Now we have two resistances in series and equivalent resistance is

$$R_e = R_1 + R_2 = 10 + 12 = 22 \Omega \text{ Ans.}$$

Hence current $I = \frac{100}{22} = 4.54 \text{ A}$. So current through 10Ω resistance is 4.54 A and the same current has to divide in the parallel branches in the inverse ratio of their resistances. We know that

$$I_1 = I \frac{R_2}{R_1 + R_2} = 4.54 \times \frac{30}{20 + 30} = 2.73 \text{ Amp.}$$

Hence

$$I_2 = I - I_1 = 4.54 - 2.73 = 1.81 \text{ Amp. Ans.}$$

Voltage drop across and power dissipated in each resistor can be obtained.

Example i.17. Determine the current in each branch of the network shown.

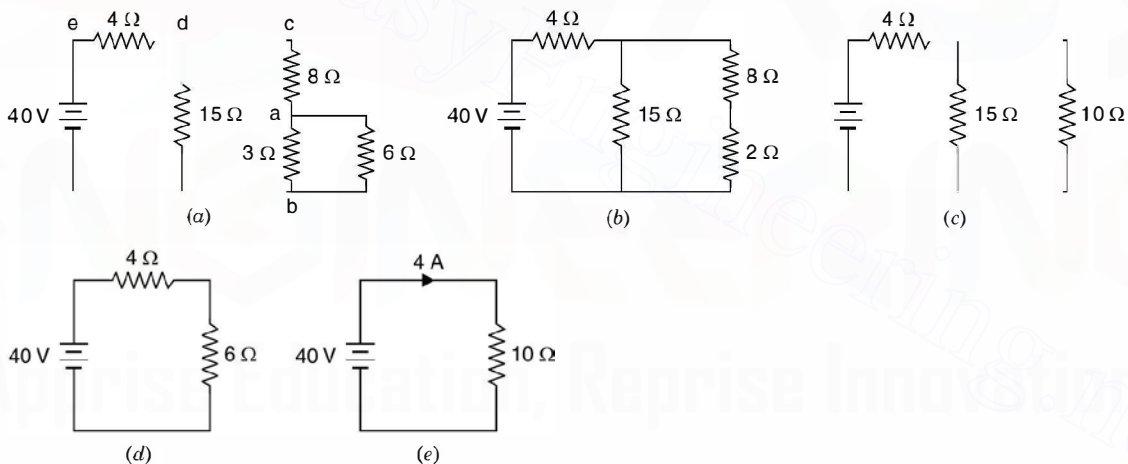

Fig. Ei.17

Solution. The various steps have been shown in the figures above. Fig. Ei.17 (b) is obtained by finding equivalent of parallel resistance 3Ω and 6Ω

i.e.
$$\frac{3 \times 6}{3 + 6} = 2 \Omega$$

In Fig. i.17 (c) two series resistances 2Ω and 8Ω have been combined. In Fig. i.17 (d) parallel combination of 15Ω and 10Ω

$\frac{15 \times 10}{10 + 15} = 6 \Omega$ has been replaced by 6Ω and finally in Fig. i.17 (e) two series resistances 4Ω and 6Ω have been combined $4 + 6 = 10 \Omega$

Therefore, current from the battery is $\frac{40}{10} = 4$ A and same current flows through 6Ω of

Fig. i.17 (a). Now in Fig. i.17 (c) current through 15Ω is $\frac{4 \times 10}{25} = 1.6$ A and hence current through 10Ω resistance is $4 - 1.6 = 2.4$ A.

So, in Fig. i.17 current through 8Ω and 2Ω is 2.4 A.

In Fig. i.16 (a) current through 6Ω is

$$2.4 \times \frac{3}{3+6} = 2.4 \times \frac{1}{3} = 0.8 \text{ A}$$

and hence current through 3Ω is $2.4 - 0.8 = 1.6$ Amp. **Ans.**

Let us consider a few applications of KVL for solving electric circuits.

Example i.18. Determine the current in all the branches of the network using loop analysis.

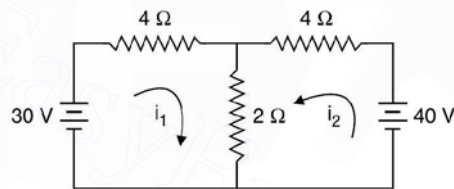

Fig. Ei.18

Solution. Let the currents i_1 and i_2 be flowing in the two loops as shown. It is to be noted that the direction of the currents is arbitrary. However, depending upon the values of i_1 and i_2 thus obtained we can ascertain the direction. If they are coming out to be positive, the directions remain as shown in the figure, otherwise one with negative value, the direction of this current is reversed.

Writing loop equation for loop 1

$$4i_1 + 2(i_1 + i_2) = 30$$

$$\text{or} \quad 6i_1 + 2i_2 = 30 \quad \dots(1)$$

$$\text{Loop 2} \quad 4i_2 + 2(i_1 + i_2) = 40$$

$$\text{or} \quad 2i_1 + 6i_2 = 40 \quad \dots(2)$$

Multiplying equation (2) by 3 and subtracting equation (1) from this we have

$$16i_2 = 90 \quad \text{or} \quad i_2 = 5.625 \text{ A}$$

$$\text{Hence} \quad 2i_1 + 6 \times 5.625 = 40$$

$$2i_1 = 40 - 33.75$$

$$\text{or} \quad 2i_1 = 6.25, \quad i_1 = 3.125 \text{ A} \quad \text{Ans.}$$

$$\text{Hence} \quad i_3 = i_1 + i_2 = 5.625 + 3.125 = 8.75 \text{ A}$$

The current through 2Ω branch is 8.75 A.

Since both the currents i_1 and i_2 are found to be positive hence the directions shown in Fig. Ei.18 is correct.

Suppose we take the direction of current for i_2 as shown in Fig. Ei.18.1 shown here

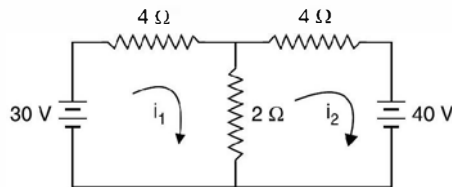

Fig. Ei.18.1

For loop 1

$$4i_1 + 2(i_1 - i_2) = 30$$

or $6i_1 - 2i_2 = 30$... (1)

$$4i_2 + 2(i_2 - i_1) + 40 = 0$$

or $-2i_1 + 6i_2 = -40$... (2)

Multiply equation (2) by 3 and add to equation (1)

$$16i_2 = -120 + 30 = -90$$

$$i_2 = -5.625$$

and $-2i_1 - 33.75 = -40$

or $-2i_1 = -6.25$

or $i_1 = 3.125 \text{ A}$

We find the i_2 is coming out to be negative and hence the direction of current in loop 2 should be opposite to what is shown in Fig. Ei.18.1.

Example i.19. Determine the current in each branch of the network shown in Fig. Ei.19 using loop analysis.

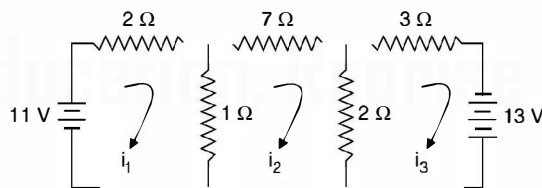

Fig. Ei.19

Solution. Since there are three loops, three independent loop equations are required to solve the network. Suppose the directions of currents are as shown in Fig. Ei.19. Writing equations for the three loops

Loop I $2i_1 + 1(i_1 - i_2) = 11$
 $3i_1 - i_2 = 11$... (1)

Loop II $7i_2 + 2(i_2 - i_3) + (i_2 - i_1) = 0$
 or $-i_1 + 10i_2 - 2i_3 = 0$... (2)

Loop III $3i_3 + 2(i_3 - i_2) = 13$
 $-2i_2 + 5i_3 = 13$... (3)

In matrix form the equations can be written as

$$\begin{bmatrix} 3 & -1 & 0 \\ -1 & 10 & -2 \\ 0 & -2 & 5 \end{bmatrix} \begin{bmatrix} i_1 \\ i_2 \\ i_3 \end{bmatrix} = \begin{bmatrix} 11 \\ 0 \\ 13 \end{bmatrix}$$

Hence $\det [A]$

$$= \begin{vmatrix} 3 & -1 & 0 \\ -1 & 10 & -2 \\ 0 & -2 & 5 \end{vmatrix}$$

$$= 3(50 - 4) + 1(-5) = 133$$

$$i_1 = \frac{\begin{vmatrix} 11 & -1 & 0 \\ 0 & 10 & -2 \\ 13 & -2 & 5 \end{vmatrix}}{133} = 11(50 - 4) + 26 = 11 \times 46 + 26$$

$$= \frac{532}{133} = 4\text{A}$$

$$i_1 = 4\text{A}$$

From equation 1

$$3 \times 4 - i_2 = 11$$

or $-i_2 = -1$

or $i_2 = 1\text{A}$

and from equation (3)

$$-2 + 5i_3 = 13 \text{ or } 5i_3 = 15$$

or $i_3 = 3\text{A}$ **Ans.**

Example i.20. Determine the currents i_1 , i_2 and i_3 and the Voltage V_1 and V_2 in the given network.

Using KVL we have

Loop I $0.2 i_1 + (i_1 - i_2) 3.75 = 120$

Loop II $3.75 (i_2 - i_1) + 0.3 i_2 + 5.45 (i_2 - i_3) = 0$

Loop III $5.45 (i_3 - i_2) + 0.1 i_3 = 110$

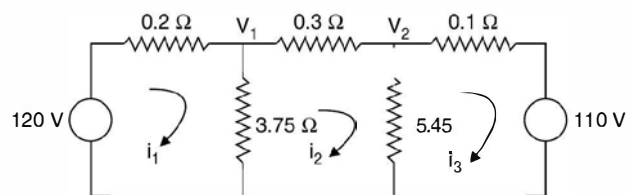

Fig. Ei.20

Rearranging the equations, we have

$$(0.2 + 3.75) i_1 - 3.75 i_2 = 120$$

$$-3.75 i_1 + (3.75 + 0.3 + 5.45) i_2 - 5.45 i_3 = 0$$

$$-5.45 i_2 + (5.45 + 0.1) i_3 = 110$$

These equations can be written in matrix form as follows

$$\begin{bmatrix} (0.2 + 3.75) & -3.75 & 0.0 \\ -3.75 & (3.75 + 0.3 + 5.45) & -5.45 \\ 0.0 & -5.45 & 5.45 + 0.1 \end{bmatrix} \begin{bmatrix} i_1 \\ i_2 \\ i_3 \end{bmatrix} = \begin{bmatrix} 120 \\ 0.0 \\ 110 \end{bmatrix}$$

or

$$ZI = V$$

Here Z matrix is the loop impedance matrix and is found to be a symmetric matrix along its leading diagonal.

It can be seen that the loop impedance matrix can be written by inspection of the loops.

(i) The diagonal elements are the sum of all the branch impedances in the corresponding loop.

(ii) The off-diagonal elements say Z_{12} is the impedance of the branches common to both the loop 1 and 2. The sign is positive if current i_1 and i_2 in the common branch flow in the same direction and is taken as negative if the two currents oppose each other.

The above set of these equations can again be written in matrix form as follows:

$$\begin{bmatrix} 3.95 & -3.75 & 0.0 \\ -3.75 & 9.50 & -5.45 \\ 0.0 & -5.45 & 5.55 \end{bmatrix} \begin{bmatrix} i_1 \\ i_2 \\ i_3 \end{bmatrix} = \begin{bmatrix} 120 \\ 0.0 \\ 110 \end{bmatrix}$$

Using Cramer's rule

$$i_1 = \frac{\begin{vmatrix} 120 & -3.75 & 0.0 \\ 0.0 & 9.50 & -5.45 \\ 110 & -5.45 & 5.55 \end{vmatrix}}{\begin{vmatrix} 3.95 & -3.75 & 0.0 \\ -3.75 & 9.50 & -5.45 \\ 0.0 & -5.45 & 5.55 \end{vmatrix}} = \Delta$$

Similarly

$$i_2 = \frac{\begin{vmatrix} 3.95 & 120 & 0.0 \\ -3.75 & 0.0 & -5.45 \\ 0.0 & 110 & 5.55 \end{vmatrix}}{\Delta}$$

Similarly expression for i_3 can be written. On solution the approximate values of i_1 , i_2 and i_3 are found to be 40 A, 10 A and -10 A. Here -10 A in the third loop means the direction of current in the third loop should be opposite to what has been assumed at the beginning of the solution.

$$\begin{aligned} \text{The voltage } v_1 &= (i_1 - i_2) 3.75 \\ &= 30 * 3.75 \\ &= 112.5 \text{ volts} \end{aligned}$$

and

$$V_2 = 20 \times 5.45 = 109 \text{ volts}$$

Example i.21. Determine the current in the battery, the current in each branch and the p.d. across AB in the network shown.

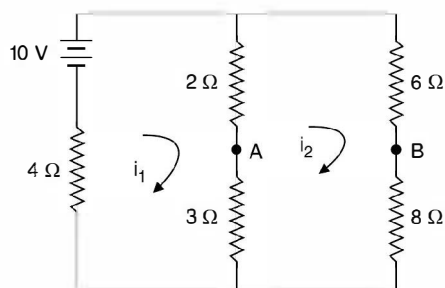

Fig. Ei.21

Using KVL we have the equations in the matrix form.

$$\begin{bmatrix} 9 & -5 \\ -5 & 19 \end{bmatrix} \begin{bmatrix} i_1 \\ i_2 \end{bmatrix} = \begin{bmatrix} 10 \\ 0 \end{bmatrix}$$

From second equation

$$-5 i_1 + 19 i_2 = 0$$

or

$$i_1 = \frac{19}{5} i_2$$

From first equation

$$9 i_1 - 5 i_2 = 10$$

$$\frac{171}{5} i_2 - 5 i_2 = 10$$

or

$$i_2 = \frac{10 \times 5}{146} \quad \text{or} \quad i_1 = \frac{190}{146} = 1.3 \text{ A}$$

Alternative solution:

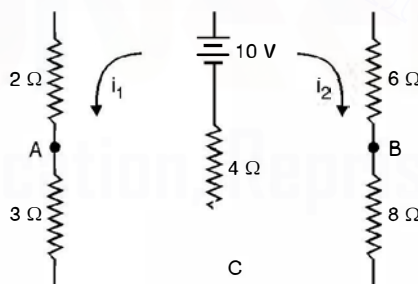

Fig. Ei.21.1

Using KVL we have

$$9 i_1 + 4 i_2 = 10 \quad \dots(1)$$

$$4 i_1 + 18 i_2 = 10$$

or

$$9 i_1 + 4 i_2 = 4 i_1 + 18 i_2$$

or

$$i_1 = \frac{14}{5} i_2$$

Substituting in (1) we have

$$9 \times \frac{14}{5} + 4 i_2 = 10$$

or

$$i_2 = 0.343$$

and

$$i_1 = \frac{14}{5} \times \frac{50}{146} = 0.96 \text{ A}$$

Therefore current through the battery 1.303 A.

Potential of A w.r. to C $0.96 \times 3 = 2.88 \text{ v}$

and that of B w.r. to C $0.343 \times 8 = 2.744$

$$V_{AB} = V_A - V_B = 2.88 - 2.74 = 0.14 \text{ v} \text{ Ans.}$$

Example i.22. Determine the current through the branch AB of the network shown.

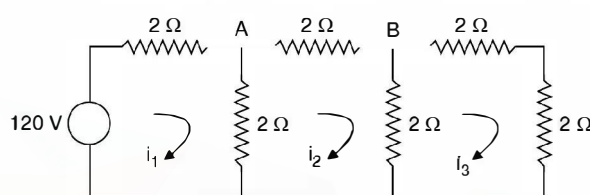

Fig. Ei.22

Using KVL we have

$$\begin{bmatrix} 4 & -2 & 0 \\ -2 & 6 & -2 \\ 0 & -2 & 6 \end{bmatrix} \begin{bmatrix} i_1 \\ i_2 \\ i_3 \end{bmatrix} = \begin{bmatrix} 10 \\ 0 \\ 0 \end{bmatrix}$$

Using Cramer's rule

$$i_2 = \frac{\begin{vmatrix} 4 & 10 & 0 \\ -2 & 0 & -2 \\ 0 & 0 & 6 \end{vmatrix}}{\begin{vmatrix} 4 & -2 & 0 \\ -2 & 6 & -2 \\ 0 & -2 & 6 \end{vmatrix}} = \frac{15}{13} \text{ A Ans.}$$

We now illustrate the application of KCL for solving the networks.

Example i.23. Determine the current in the branches of the network in Fig. Ei.23 using nodal analysis.

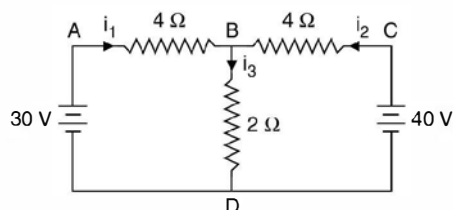

Fig. Ei.23

Solution. There are four nodes A, B, C, D as shown in the network. Taking node D as reference, we are left with three nodes A, B and C . Voltages of nodes A and C with respect to reference node are known to be 30 V and 40 V respectively. Hence voltage of only one node is not-known. Hence we need write only one equation at node B .

$$i_1 + i_2 = i_3$$

$$\text{or } \frac{30 - V_B}{4} + \frac{40 - V_B}{4} = \frac{V_B}{2}$$

$$\text{or } 30 - V_B + 40 - V_B = 2V_B$$

$$\text{or } 4V_B = 70 \quad \text{or } V_B = 17.5 \text{ volts}$$

$$\text{Hence } i_1 = \frac{30 - 17.5}{4} = 3.125 \text{ A}$$

$$i_2 = \frac{40 - 17.5}{4} = 5.625$$

$$\text{and } i_3 = i_1 + i_2 = 8.75 \text{ A} \quad \text{Ans.}$$

Example i.24. Determine the current's in all branches of the network shown in Fig. Ei.24

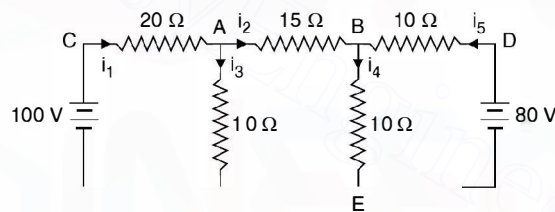

Fig. Ei.24

Solution. Taking node E as reference and since the potentials of nodes C and D with respect to E are known hence only two independent nodes are A and B where the voltages be V_A and V_B respectively.

Writing nodal equation at node A

$$\frac{100 - V_A}{20} - \frac{V_A - V_B}{15} - \frac{V_A}{10} = 0$$

$$\text{or } 5 = \frac{V_A}{20} + \frac{V_A}{15} - \frac{V_B}{15} + \frac{V_A}{10}$$

$$25 = \frac{V_A}{4} + \frac{V_A}{3} - \frac{V_B}{3} + \frac{V_A}{2}$$

$$300 = 3V_A + 4V_A - 4V_B + 6V_A$$

$$\text{or } 13V_A - 4V_B = 300 \quad (1)$$

At node B

$$\frac{V_A - V_B}{15} + \frac{80 - V_B}{10} = \frac{V_B}{10}$$

$$\frac{V_A - V_B}{3} + \frac{80 - V_B}{2} = \frac{V_B}{2}$$

$$2V_A - 2V_B + 240 - 3V_B = 3V_B$$

$$2V_A - 8V_B = -240$$

or
$$-V_A + 4V_B = 120 \quad \dots(2)$$

Adding equation (1) and (2) we have

$$12V_A = 420$$

$$V_A = 35 \text{ volts}$$

Hence
$$-35 + 4V_B = 120$$

or
$$4V_B = 155$$

or
$$V_B = 38.75 \text{ volts}$$

Hence current
$$i_1 = \frac{100 - 35}{20} = \frac{65}{20} = 3.25 \text{ A}$$

$$i_2 = \frac{35 - 38.75}{15} = -\frac{3.75}{15} = -0.25$$

The value of i_2 is coming out to be negative which means in the actual circuit the direction of current should be opposite to what is shown in Fig. Ei.24.

Hence
$$i_3 = i_1 + i_2 = 3.25 + 0.25 = 3.5$$

$$i_4 = \frac{V_B}{10} = \frac{38.75}{10} = 3.875 \text{ A}$$

and hence
$$i_5 = i_2 + i_4 = 0.25 + 3.875$$

$$= 4.125 \text{ Amp Ans.}$$

PROBLEMS

- i.1. What are international system of units ? Discuss its advantages over other systems of units.
- i.2. What are Fundamental and Derived units ? Discuss their correlation if any.
- i.3. Define and explain the terms "Electric current", "Electric potential", power, and energy and give their units .
- i.4. Define resistance and discuss various factors on which resistance of a conductor depends.
- i.5. State and explain ohm's law using some experimental set up diagram.
- i.6. State and explain with neat diagram Kirchhoff's laws for electric circuits.
- i.7. Two voltmeters A and B having resistances of 5000 ohms and 15000 Ω respectively are joined in series across 240 V. Determine the reading of each voltmeter. [Ans. 60 V, 180 V]

- i.8. (a) A potential difference of 10 V is applied across a 2.5Ω resistor. Calculate the current, the power dissipated and the energy transformed into heat in 5 min. (b) If a resistor is to dissipate energy at the rate of 250 W, determine its resistance for a terminal voltage of 100 V.
[Ans. (a) 4A, 40 W, 12000 watt-sec (b) 40 Ω]
- i.9. Determine the current in each branch of the given network, if the total current is 2.25 A. Also determine the value of R.
[Ans. $I_1 = 1$ A, $I_2 = 1.25$ A, $R = 3 \Omega$]

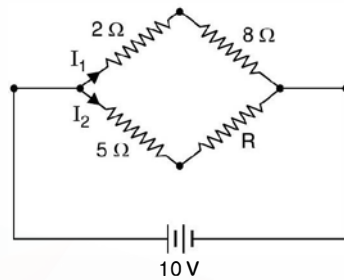

Fig. Q.i.9

- i.10. The voltage drop in a resistor is 12 volts when the current is 6 amp. Determine the resistance and conductance.
[Ans. 2 Ω , 0.5 S]
- i.11. A series circuit of lamps consists of eight 6 W lamps for use on a 120 V supply. Determine the current and resistance of each lamp.
[Ans. 0.4 A, 37.5 Ω]
- i.12. Three resistors 26 Ω , 32 Ω and 18 Ω are in parallel, determine the total resistance. [Ans. 7.9 Ω]
- i.13. Three resistors 750 Ω , 620 Ω and 200 Ω are in parallel. If the total current is 1 A. Determine the applied voltage and branch currents.
[Ans. 125 V, 0.202 A, 0.167 A, 0.625 A]
- i.14. A 60 W, a 40 W and a 75 Watt lamps are connected across a supply of 120 V. Determine the total resistance and total current.
[Ans. 82 Ω , 1.46 A]
- i.15. Two resistors 12 Ω and 20 Ω are in parallel. The total current is 17 A. Determine the branch currents.
[Ans. 10.625 A, 6.375 A]
- i.16. A voltage of 2.2 V is applied to a parallel circuit. The conductance of one branch is 0.205 and the conductance of the other branch is 7800 μ S. Determine the branch current and the total current.
[Ans. 0.44A, 17.2 mA, 457.2 mA]
- i.17. Determine the power dissipated in each resistance of the circuit shown and the voltage drop across 5 Ω resistor.
[Ans. 367 in 5 Ω , 326 in 10 Ω , 164 W in 20 Ω 42.9 volts]

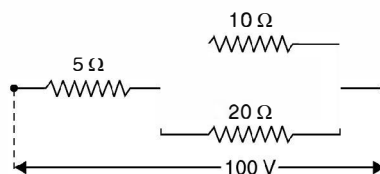

Fig. Q.i.17

- i.18. A current of 20 A flows through two ammeters A and B joined in series. Across A the p.d. is 0.2 V and across B it is 0.3 V. Determine how the same current will divide between A and B when they are joined in parallel.
[Ans. 12 A, 8A]

CHAPTER

ii

Electromagnetic Induction**ii.1 INTRODUCTION**

In 1820 Oersted discovered that a current carrying wire could be made to deflect a freely suspended magnetic needle. Faraday repeated Oersted experiment and went ahead to show that it was not only possible to move the magnet round a current carrying conductor but it was possible for a current carrying wire to move round a magnet. The reason for the phenomenon however remained mystery for quite sometime.

Both Oersted and Ampere's searched this answer from the behavior of the conductor and magnet. However, Faraday conceived the forces to be due to tension in the medium in which the magnets or conductors were placed. In fact, because of his this approach which led Faraday to introduce the concept of lines of force. In 1831 Faraday showed that electricity could be produced from magnetism. He demonstrated with the help of simple experiments the current can be made to flow in a circuit whenever (i) current in a neighbouring circuit is made to flow or is interrupted (ii) a magnet is brought near a closed circuit and (iii) a closed circuit is moved near a magnet or a current carrying conductor.

In first case he wound two coils on a toroid, one coil is shorted through a galvanometer and across the other a dc source through a switch is connected. When the switch is closed there is sudden change in current during a small time interval and hence there is change in flux linkages and voltage is induced in the other circuit which circulates current through the galvanometer which gives deflection. He further found that when the battery circuit is switched off, the galvanometer gives deflection again, though in the opposite direction.

In the second and third observation he had a coil shorted through a galvanometer. Here he found that, whenever there is relative motion between the coil and a magnet, the galvanometer gave deflection.

ii.2 FARADAY'S LAWS OF ELECTROMAGNETIC INDUCTION

Faraday's laws state that an emf is induced in a circuit which is

- (i) Directly proportional to the time rate of change of flux enclosed by the circuit.
- (ii) Directly proportional to N the no. of turns of the circuit.

Combining, the two laws, Faraday's laws of induction can be expressed mathematically as

$$e = -N \frac{d\phi}{dt} \text{ volts} \quad (\text{ii.1})$$

Here negative sign is due to Emil Lenz, who subsequent to Faraday's experiments suggested that the direction of the induced current is always such as to oppose the action that produced it.

As we know Faraday's law as given by equation (ii.1) is one of the two basic relationships upon which the whole theory of electromagnetic and electromechanical energy conversion devices are based and today we have the generator and motor (electric) operating based on this theory.

Also Faraday was the first to identify emf of self induction, *i.e.*, here we have only one coil and it is connected to a dc source through a switch. When current is flowing through this coil and the circuit interrupted through the switch an emf is induced in the coil. This is known as emf of self induction expressed mathematically

$$e = L \frac{di}{dt} \quad (\text{ii.2})$$

Where L is a proportionality constant called the co-efficient of self inductance which depends upon the medium and other physical parameter we will discuss in later section of this chapter.

ii.3 LENZ'S LAW

As in laws of mechanics, to every action there is an equal and opposite reaction. The fact that this law holds good in electromagnetism was discovered by Emil Lenz.

Lenz law states that this induced current always develops a flux which opposes the very cause it is due to. This law refers to induced currents and therefore, implies that it is applicable to closed circuits only. However, if the circuit is open it is possible to find the direction of induced emf by assuming as if the circuit were closed.

Equation (ii.2) is also known as Lenz's law. In order to study properties of a coil using Lenz's law, thus it is the current changes through the coil rather than flux changes, should be considered. Assume that a voltage V is required to maintain a constant current I in a coil. The power VI is required to overcome the heating loss in the resistance component of the coil. Suppose the supply voltage V is increased by an amount $+\Delta V$, there is increase in current by $+\Delta I$. As per equation (ii.2) a voltage e is induced within the coil $e = L \frac{\Delta I}{\Delta t}$. This voltage is in a direction that opposes the increase in current. If, however V is reduced by an amount $-\Delta V$, the current I will decrease by an amount $-\Delta I$. The polarity of the induced voltage ($-e$) is changed and tries to oppose the reduction in current. The action of opposition within the coil itself is similar to the action encountered in mechanics as a property of a mass called inertia.

ii.4 LAWS OF ELECTROMAGNETIC FORCES

As mentioned earlier Oersted discovered that a current flowing in a conductor deflected the needle of a compass and that the paths of magnetic forces are concentric circle around the conductor. If iron filings are scattered on a cardboard held at right angle to a current carrying conductor the iron filings form in circular patterns.

Ampere experimented with this phenomenon and formulated mathematical expressions describing his observation. Consider two very long parallel conductors separated r metres and carrying currents I_1 and I_2 as shown in Fig. ii.1 (c).

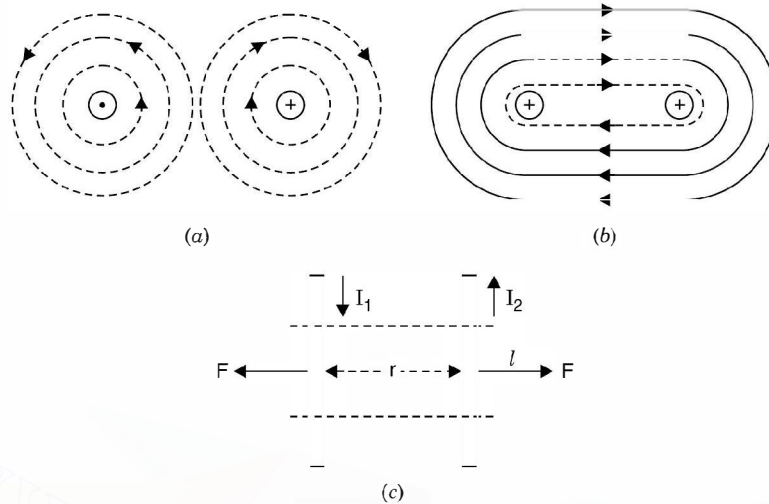

Fig. ii.1 (a) Two parallel long current carrying conductor in opposite direction
(b) in same direction (a) a section l of the long conductor.

Consider Fig. ii.1(c) where a short length of the conductor is shown. Since the currents in the two conductors are flowing in opposite direction; there will be force of repulsion between the two conductors. This is further explained in Fig. ii.1(a). We find that the flux lines in the middle add together as the direction of flux lines is the same in the middle space whereas if the two currents were equal there will be no flux line enclosing both the conductors and hence the inner flux lines will pull the two conductor apart 'i.e.' the two will have force of repulsion. However if $I_1 \neq I_2$, there will be fewer flux lines enclosing the two conductor and still the pull from the flux between the conductors will be much larger and the conductors will be repelled. However in Fig. ii.1(b) it can be seen from the flux distribution, when the two conductors are carrying current in the same direction, will attract each other. The flux lines within the space cancel out if $I_1 = I_2$ or else there will be very few and with less intensity and flux lines enclosing both the conductors gets strengthened and hence there will be force of attraction between the two conductors.

From experimentation Ampere's found that the force F is directly proportional to the product of currents in the two conductors and also directly proportional to the length ' l ' of the section considered and inversely proportional to distance of separation r between the conductors i.e.

$$F \propto \frac{I_1 I_2 l}{r} \quad (\text{ii.3})$$

By using constant of proportionality k equation (ii.3) is rewritten as

$$F = k \frac{I_1 I_2 l}{r} \quad (\text{ii.4})$$

In terms of SI units k is found to be equal to $\frac{\mu_0}{2\pi}$

Hence equation (ii.4) becomes

$$F = \frac{\mu_0}{2\pi} \frac{I_1 I_2 l}{r} \text{ Newton} \quad (\text{ii.5})$$

Where μ_0 is the permeability of free space and its magnitude is

$$\mu_0 = 4\pi \times 10^{-7} \text{ Henry/metre}$$

We also know that when a current carrying conductor is brought in the domain of a magnetic field, the conductor experiences a force. The direction of the force is given by Fleming's left hand rule. The length of the current carrying conductor should not be parallel to the magnetic field. The force will be maximum when the two are perpendicular to each other.

Consider Fig. ii.2. Fig. ii.2 (a) shows two current carrying conductors separated by a distance r .

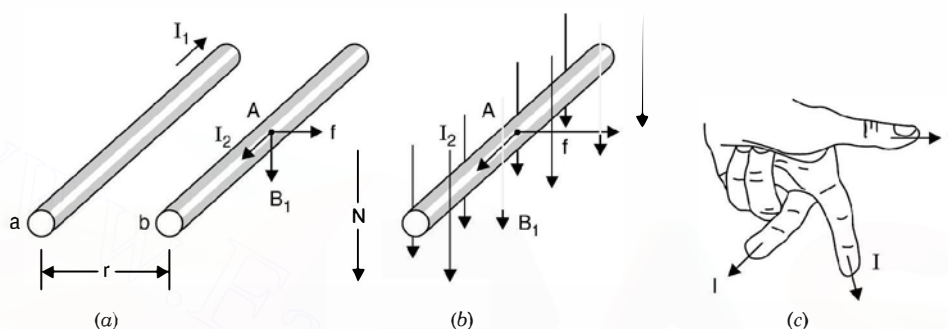

Fig. ii.2 (a) The force between two conductors carrying current, (b) The force on a single conductor in a uniform magnetic field, (c) The left-hand rule.

The magnetic flux density due to a long conductor carrying current I_1 amp at a distance r is given by

$$B = \frac{\mu_0 I}{2\pi r} \quad (\text{ii.6})$$

and the direction of flux density using cork screw rule will be downward and will be at right angle to the current carrying conductor 'b' with I_2 amperes and at a distance r . As mentioned above conductor 'b' is brought in a magnetic flux density B will experience a force which is given by equation (ii.5) and is reproduced and written in a particular fashion.

$$F = \left(\frac{\mu_0 I_1}{2\pi r} \right) I_2 l \quad (\text{ii.7})$$

Now substituting B for $\frac{\mu_0 I_1}{2\pi r}$ from equation (ii.6.)

$$\text{We have} \quad F = BI_2 l \text{ Newton} \quad (\text{ii.8})$$

Each of the three quantities F , B and I_2 are vector quantities and Fleming's left hand is used to indicate direction of force. Fleming's left-hand rule is stated as follows:

ii.4.1 Fleming's Left Hand Rule

Hold the thumb, the fore finger and the central figure at right angle to each other of the left hand as shown in Fig. ii.2 (c). If the fore-finger points in the direction of magnetic field and the central finger to the direction of current, the thumb will point to the direction of force or motion.

The vectors B and F are perpendicular to each other and lie in a plane that is perpendicular to the conductor. If any one of these is not perpendicular to the plane formed by the other two by an acute angle θ , equation (ii.8) should be modified to

$$F = BIl \sin \theta \text{ Newton} \quad (\text{ii.9})$$

This equation can be rewritten as a cross product of two vectors and is given as

$$F = I\vec{l} \times \vec{B} \quad (\text{ii.10})$$

and θ is the angle between the vectors representing the direction of current (\vec{l}) flow and the direction of magnetic flux density.

We have seen in the previous articles on Faraday's laws of electromagnetic induction that whenever a conductor is moved in a magnetic field or if the conductor is stationary and the field is moved, voltage is induced in the conductor. This is known as generator action and the polarity of the voltage induced is given by Fleming's right hand rule. Which is stated as follows:

ii.4.2 Fleming's Right Hand Rule

Hold the thumb, fore-finger and the central finger of the right hand at right angles to each other. If the thumb points to the direction of motion and forefinger to the direction of field, the central finger will point in the direction of induced emf. *i.e.* the central finger will point to the positive terminal of emf or will indicate the direction of current flow if the ends of the conductor are connected to the external circuit *i.e.*, the load.

ii.5 DYNAMICALLY INDUCED EMF (GENERATOR OR MOTIONAL EMF)

As mentioned earlier when a conductor is moved in a magnetic field, voltage induced is maximum if the length of the conductor and magnetic field are at right angle. Consider Fig. ii.3 where three conductors a , b and c are shown moving in a magnetic field in different directions.

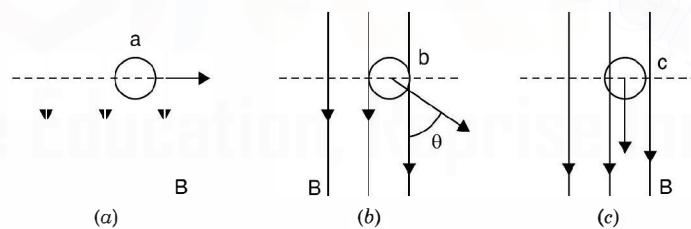

Fig. ii.3 Motion of a conductor in a magnetic field (a) Perpendicular (b) at an angle θ (c) parallel to field.

Conductor 'a' is moving at right angle to its own length say ' l ' and at right angle to the magnetic field. Suppose in a time dt , the conductor 'a' moves through a distance dx . If flux density is B , the flux cut by a single turn coil is $B \times \text{area}$. The area here is $l dx$ hence the flux cut by the coil in dt time is

$$d\phi = B \cdot l \cdot dx$$

Using Faraday's law equation (ii.1)

$$e = -N \frac{d\phi}{dt} \text{ and since here } N = 1$$

$$e = - \frac{d\phi}{dt} = -B \cdot \frac{ldx}{dt}$$

Since B and l are constant and not function of time

$$e = -Blv \quad \text{(ii.11)}$$

where v is the velocity with which the conductor is moving at right angle to the flux density B .

In Fig. ii.3 (b), the conductor moves at angle θ with respect to magnetic field. Therefore, if the conductor moves a distance dx in time dt , the component of distance moved at right angle to the field is $dx \sin \theta$ and hence the flux cut by the conductor

$$= B \cdot l dx \sin \theta \text{ and hence } e = -Blv \sin \theta \quad \dots \text{(ii.12)}$$

However in Fig. ii.2 (c) since the conductor is moving parallel to the flux density hence $\theta = 0$ and the voltage induced in the coil is zero, Equation (ii.12) is a general equation for evaluating emf induced in coil moving in a static magnetic field. Equation (ii.12) can be written in vector notation as

$$e = -l (\vec{v} \times \vec{B}) \text{ volts} \quad \text{(ii.13)}$$

Next we take up statically induced emf.

ii.5.1 Statically Induced emf or Transformer emf

Here we consider the circuit or conductor or coil to remain stationary but the magnetic field is time varying. The statically induced emf may be (i) mutually induced or (ii) self induced.

In the first-case we have two windings placed close to each other and a time varying voltage source is connected to one winding which induces voltage in the other winding. In the second case we have single winding and when a time varying voltage source is connected across its terminals, time varying current through the winding gives rise to time varying magnetic field which links the winding itself and emf is induced in the winding and hence this emf induced is known as self induced.

Suppose we have a flux density normal to a differential area ds and the coil in the field is single turn, then flux linkage ψ can be given as

$$\psi = \iint \vec{B} \cdot \vec{ds}$$

The surface over which the integration is to be carried out is the surface bounded by the periphery of the coil. The induced e.m.f. is therefore, given as

$$e = \frac{d\psi}{dt} = - \frac{d}{dt} \iint \vec{B} \cdot \vec{ds} \quad \text{(ii.14)}$$

and for a time varying magnetic field

$$e = - \oint_s \frac{dB}{dt} \cdot ds \quad \text{(ii.15)}$$

If we consider the flux density to be harmonically varying and let the area through which the flux flows is constant then let $\phi = \phi_m \sin \omega t$ and let N be the no. of turns of the coil, the flux linking will be

$$\psi = \phi N = N\phi_m \sin \omega t$$

Hence

$$e = - \frac{d\psi}{dt} = -N \phi_m \omega \cos \omega t$$

$$= N \phi_m \omega \sin (\omega t - \pi/2)$$

Which shows that the harmonically varying flux induces a sinusoidal voltage which lags behind the flux itself by 90° in time phase.

ii.6 SELF INDUCTANCE

When a coil is connected to an ac source, it draws certain current which is changing as a function of time and hence this current produces a flux which changes with time. So it is a case of stationary circuit but the flux is changing as a function of time which induces emf in the coil. Since the emf is induced in the coil itself in which the circuit/flux is changing, this emf is known as self induced emf. Since it is mainly due to changing current; the voltage induced is given by

$$e = L \frac{di}{dt} \quad (\text{ii.16})$$

Here e is the self induced emf in volts

$\frac{di}{dt}$ is the time rate of change of current

and L is known as self inductance as it is the quantity of the circuit itself or it is also known as coefficient of self inductances or simply inductance and its unit is Henry. According to Lenz's law the polarity of the emf so induced is such that it opposes the change of current *i.e.* it opposes the external source of voltage as shown in Fig. ii.4.

We also know, according to Faraday's law of electromagnetic induction that

$$e = N \frac{d\phi}{dt}$$

Where N is the no. of turns in the coil and $\frac{d\phi}{dt}$ is the time rate of change of flux.

Equating this equation with equation (ii.16) we have

$$L \frac{di}{dt} = N \frac{d\phi}{dt}$$

$$L = \frac{N d\phi}{di} \quad (\text{ii.17})$$

or

However, if the $B-H$ curve of the magnetic core over which the coil is wound is a straight line *i.e.* there is no saturation of the core then ϕ and i are linearly related and equation (ii.17) can be rewritten as

$$L = \frac{N\phi}{i} \quad (\text{ii.18})$$

This equation defines inductance of a coil and is given as flux linkage per ampere and is a constant quantity. However, we know that $B-H$ curve gets saturated *i.e.*, with increase in current after certain value of current, the flux does not increase linearly. Rather the increase in flux is relatively smaller and hence, the change in flux linkage per ampere reduces which means the effective inductance of the coil decreases. The variation of inductance as a function of current is shown in Fig. ii.5.

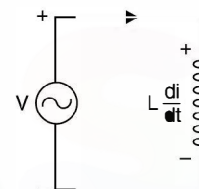

Fig. ii.4 A coil connected to ac voltage source.

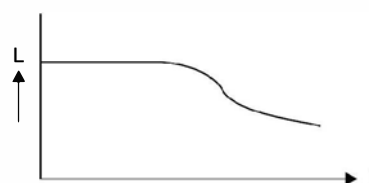

Fig. ii.5 Variation of inductance as I varies.

If we have to find out inductance of a given coil when the saturation of the core takes place we make use of equation (ii.17) and we define inductance as the ratio of differential change in flux linkages to differential change in current.

To obtain physical dimensions of the coil we make use of equation (ii.18)

$$\text{Since } \phi = \frac{MMF}{\text{Reluctance}} = \frac{Ni}{l/\mu A}$$

Substituting for ϕ in equation (ii.18) we have

$$L = \frac{N\{Ni/(l/\mu A)\}}{i} = \frac{N^2\mu A}{l} \quad (\text{ii.19})$$

i.e. the inductance of a coil is directly proportional to (i) Square of number of turns (ii) directly proportional to the permeability of the core material and area of cross-section of the core and inversely proportional to the length of the magnetic circuit. Usually it is the no. of turns are varied to obtain a desired value of inductance. It is to be noted that for small values of inductances in term of mH or μH , usually air cored coils are used as $\mu_r = 1$ for air and μ_r is quite high for magnetic materials.

ii.7 MUTUAL INDUCTANCE

In Fig. ii.6 current I_1 produces a total flux ϕ_{11} in coil 1. The subscript 11 means one-one and not eleven *i.e.* the flux of coil 1 that links coil 1. The resulting self inductance L_1 of coil 1 is

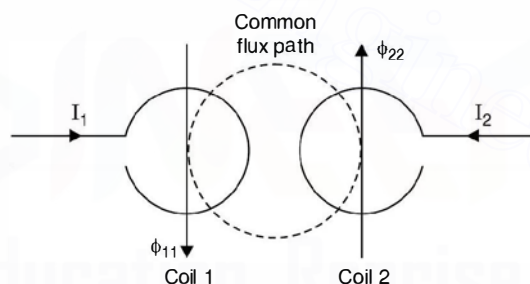

Fig. ii.6 Mutual flux and mutual inductance.

$$L_1 = \frac{N_1\phi_{11}}{I_1} \text{ H} \quad (\text{ii.20})$$

Similarly current I_2 produces a total flux ϕ_{22} in coil 2 and, therefore, the self-inductance of coil 2 is

$$L_2 = \frac{N_2\phi_{22}}{I_2} \text{ H} \quad (\text{ii.21})$$

The directions of ϕ_{11} and ϕ_{22} have been shown as per the direction of current flows in the respective coils. A part of flux ϕ_{11} links coil 2. Hence total flux in coil 2 consists of two components, its own flux ϕ_{22} plus the part of ϕ_{11} which is common. The amount of flux of coil 1 which links coil 2 is ϕ_{12} . The subscript "12" means from coil 1 to coil 2. Similarly a part of flux ϕ_{22} of coil 2 which links coil 1 is ϕ_{21} .

In Fig. ii.6, the physical placement of the coils and the direction of currents I_1 and I_2 , produce fluxes ϕ_{12} and ϕ_{21} such that these reinforce ϕ_{11} and ϕ_{22} by acting in the same direction as the original ϕ_{11} and ϕ_{22} . Thus these mutual fluxes aid the main fluxes. If, however either I_1 or I_2 is reversed, ϕ_{12} and ϕ_{21} will oppose the fluxes ϕ_{22} and ϕ_{11} . A plus sign is used when the fluxes aid each other, otherwise minus sign is used. However, it should be noted that both ϕ_{12} and ϕ_{21} should be given the same sign either plus or minus. A condition cannot exist when one is plus and the other minus.

The flux ϕ_{21} which links coil 1 having N_1 turns will have flux linkages $N_1 \phi_{21}$ and the flux ϕ_{21} is due to current I_2 in coil 2. Hence

$$M_{21} = \frac{N_1 \phi_{21}}{I_2} \quad (\text{ii.22})$$

This is the mutual inductance due to flux linkages in the coil 1. Similarly the flux ϕ_{12} which is linking coil 2 of N_2 turns and is due to current I_1 in coil 1.

Hence,
$$M_{12} = \frac{N_2 \phi_{12}}{I_1} H \quad (\text{ii.23})$$

In the discussion above we have assumed, the mutual fluxes to be additives and hence plus sign is assigned to M_{21} and M_{12} . However, if the mutual fluxes oppose the main fluxes ϕ_{11} and ϕ_{22} , then M is to be given negative sign.

We define the coefficient of magnetic coupling between the two coils as the ratio of common flux to the total flux

i.e.,
$$K_1 = \frac{\phi_{12}}{\phi_{11}} \quad \text{and} \quad K_2 = \frac{\phi_{21}}{\phi_{22}} \quad (\text{ii.24})$$

It can be shown that for any two coils K_1 and K_2 are same and M_{12} and M_{21} are also same. Hence let

$$K_1 = K_2 = K \quad \text{and} \quad M_{12} = M_{21} = M \quad (\text{ii.25})$$

Multiplying equation (ii.22) and (ii.23) and using equation (ii.25) we have

$$M^2 = M_{12} M_{21} = \frac{N_2 \phi_{12}}{I_1} \cdot \frac{N_1 \phi_{21}}{I_2} \quad (\text{ii.26})$$

From equation (ii.24) $\phi_{12} = K\phi_{11}$ and $\phi_{21} = K\phi_{22}$

Substituting values of ϕ_{12} and ϕ_{21} in equation (ii.26), we have

$$M^2 = K^2 \frac{N_1 \phi_{11}}{I_1} \cdot \frac{N_2 \phi_{22}}{I_2} = K^2 L_1 L_2$$

Hence
$$K = \frac{M}{\sqrt{L_1 L_2}} \quad (\text{ii.27})$$

or

$$M = \pm K \sqrt{L_1 L_2}$$

The coefficient of coupling represents that fraction of the flux of one coil that links a second coil. If a core is of good magnetic material, the coefficient of coupling could be as high as 0.99.

However for air cored coils, this coupling coefficient is as low on 0.05. The mutual inductance induces voltage in these coils. The coil 1 will induce a voltage $M \frac{di_1}{dt}$ in coil 2 whereas coil 2 will induce a voltage $M \frac{di_2}{dt}$ in coil 1 if the mutual fluxes are aiding. If these are opposing the main fluxes then these voltages will be $-M \frac{di_1}{dt}$ and $-M \frac{di_2}{dt}$ respectively.

ii.8 HYSTERESIS LOSS

Consider Fig. ii.7 consisting of a coil wound on a magnetic toroid. Assume that the core is initially unmagnetised. If the current i is increased *i.e.* $H = \frac{Ni}{l}$ the magnetic field intensity is increased gradually from zero value. The flux density B starts increasing as shown by oa part of the curve in Fig. ii.7 (c). The point a corresponds to a particular value of current say i_1 . If i were less than i_1 , point a will shift downwards towards o and a smaller final loop will appear.

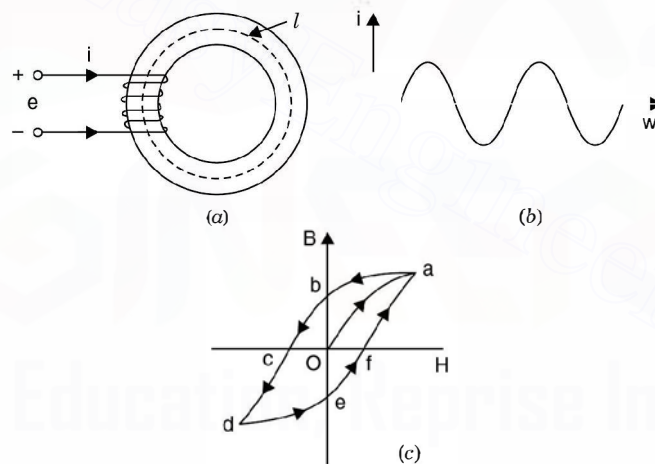

Fig. ii.7 (a) Core coil assembly (b) Existing current (c) Hysteresis loop.

Now if we decrease magnetic field intensity *i.e.* decrease current *i.e.* i , B - H curve will follow a different path, different from oa , In fact it goes along ab , point b is reached when the field intensity is zero and hence current i is zero. We see that when current through the coil is zero still there is some magnetic flux density in the core of the coil and this is known as residual flux density corresponding to point b in the Fig. ii.7 (c). If H is now reversed by reversing the flow of current i , the flux in the core will decrease and the point on the B - H curve will move along bc and when H corresponding to $-H_c$ is reached, the core is again demagnetised. The magnitude of magnetic field intensity ($-H_c$) is known as coercivity or coercive force of the magnetic core.

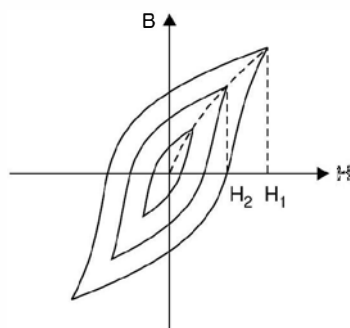

Fig. ii.8 Three hysteresis loops—magnetisations Characteristics of the magnetic core.

If H is further increased in the reverse direction the magnetic flux density will also increase in the reverse direction. If H is made corresponding current $-i_1$, the point on the B - H curve moves along the cd path. The point d corresponds to $H_d = -\frac{Ni_1}{l}$. If H is now decreased to zero and then increased to the value corresponding to current i , the B - H curve will follow the path $defa$. Usually the last point a is slightly short of the original point but for simplicity we assume that it coincides the original point while moving from d through ef and towards 'a'. However, it is found that, if the core is subjected to a few cycles of magnetisation, the loop almost closes and this loop is called hysteresis loop. The loop shows that the relationship between B and H is non linear and multivalued. It is to be noted that at point b the core is magnetised even though the current through the coil is zero. Throughout the complete cycle of magnetisation the flux density lags behind the magnetic field intensity. This lagging phenomenon in the magnetic core is known as hysteresis.

Smaller hysteresis loops can be obtained by varying maximum value of current and hence magnetic field intensity. If $i_1 > i_2 > i_3$ where i_1 , i_2 and i_3 represent three values of maximum currents and hence H_1 , H_2 and H_3 . The corresponding hysteresis loops are shown in Fig. ii.8. The locus of the tips of the hysteresis loops shown with dashed line is known as magnetisation curve. If the iron core is magnetised from an initial unmagnetised condition, the flux density will follow the magnetisation curve.

When current i is varied over one cycle, during some part of the cycle, the coil stores energy from the source and during some part, it returns energy back to the source. However, energy flowing into the coil is greater than the energy returned back to the source. Hence, during one cycle of variation of current i (Hence H) there is a net energy flow from the source to the coil core assembly. The energy difference goes to heat the core. The loss of power in the core due to hysteresis effect is known as hysteresis loss. It can be shown that the area of the hysteresis loop is proportional to the hysteresis loss.

Assuming that the coil has no resistance

$$e = N \frac{d\phi}{dt}$$

and energy transfer during time interval t_1 to t_2 is

$$W = \int_{t_1}^{t_2} ei dt \quad (\text{ii.28})$$

$$\text{or } W = \int N \frac{d\phi}{dt} i dt = \int_{\phi_1}^{\phi_2} N_i d\phi \quad (\text{ii.29})$$

$$\text{Now } \phi = B \cdot A \quad \text{and} \quad i = \frac{Hl}{N}$$

where l is the length of the magnetic path and A the area of cross-section.

Substituting these values in equation (ii.29) we have

$$W = \int_{B_1}^{B_2} N \cdot \frac{Hl}{N} \cdot A dB = lA \int_{B_1}^{B_2} H \cdot dB$$

Here lA = Volume of the magnetic circuit and the integral terms HdB represents the area shown hatched in Fig. ii.9.

The energy received by the core during one cycle is

$$\begin{aligned} W_{\text{cycle}} &= V_{\text{core}} \oint H dB \\ &= V_{\text{core}} \times \text{area of } B-H \\ &= V_{\text{core}} \times W_h \end{aligned}$$

where W_h is the energy density in the core. The power loss in the core due to hysteresis's effect is

$$P_h = V_{\text{core}} W_h f \quad (\text{ii.30})$$

where f is the frequency of current i . Since it is not possible to evaluate the area of the $B-H$ loop mathematically as the curve can't be described by some mathematical expression. Steinmetz suggested empirical relation after lot of experimentation to the area of the loop. He suggested that this can be approximated by

$$\text{Area of } B-H \text{ loop} = KB_{\text{max}}^n f \quad (\text{ii.31})$$

Where B_{max} is the maximum flux density, the value of n varies between 1.5 to 2.5 and k is a constant. Both k and n can be obtained empirically. Using equation (ii.30) and (ii.31) the hysteresis loss is given by

$$P_n = k_h B_{\text{max}}^n f \quad (\text{ii.32})$$

Here k_h depends upon the volume and ferromagnetic material of the core. Typical value for grain oriented silicon steel sheet used for electric machines is 1.6. Some typical values for k are: cast steel 0.025, silicon sheet steel 0.001, permalloy 0.0001. k is known as Steinmetz's constant.

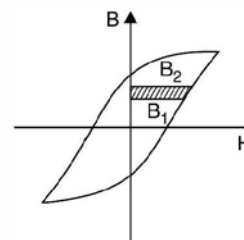

Fig. ii.9 Hysteresis loop.

ii.9 EDDY CURRENT LOSS

When a.c. voltage is applied to a coil wound on a magnetic core, the current, not only induces voltage within the coil, it induces voltage in the magnetic core also which results in what are known as circulating currents or eddy currents. These eddy currents result in a loss in magnetic materials known as eddy current loss. The circulation of these currents has been shown in Fig. ii.10. Fig. ii.10 (a) shows flow of eddy current in a solid core whereas (b) shows in a laminated core. It has been observed that eddy currents flow cross wise in the core. The magnitude of eddy current can be reduced substantially by increasing the cross-sectional resistance of the core. The cores are made of the sheets called lamination. The thickness of laminations varies from

0.5 to 5 mm in electrical machines and from 0.01 to 0.5 mm in devices used in electronic circuits which operate at frequencies. Each lamination is insulated from the others by a coating of oxides or varnish or both so that it offers a high resistance to the flow of eddy currents. The eddy current loss can also be reduced by using a high resistivity core material. Addition of a small percent of silicon say 3% to iron will increase the resistivity significantly. The eddy current loss is given by

$$P_e = K_e f^2 B_m^2 t^2 \times \text{volume}$$

where t is the thickness of laminations and K_e is a constant which depends upon the core material.

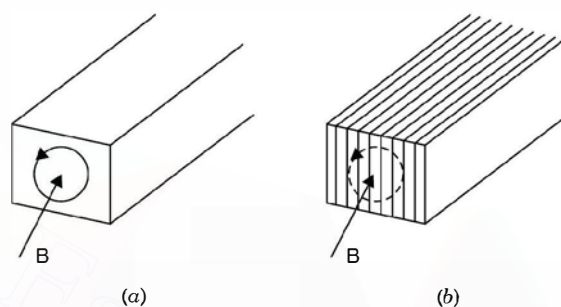

Fig. ii.10 Eddy current loss in core (a) Solid core (b) Laminated core.

The sum of the hysteresis and eddy current loss is known as core loss or iron loss. Since for a machine f and B_m are constant, the core loss is also known as constant loss of the machine.

Eddy currents can be used to advantage to electric braking purpose e.g. in moving iron and moving coil measuring instruments eddy currents are utilised to damp out the final settling of the instrument pointer. Also there are some specially designed machines which utilise eddy current braking.

Example ii.1: A wire of length 50 cms moves at right angles to its length at 50 m/sec in a uniform magnetic field of density 1 Wb/m². Determine the e.m.f. induced in the conductor when the direction of motion is (i) perpendicular to the field (ii) inclined at 30° to the direction of the field (iii) parallel to the field.

Solution. Voltage induced in a conductor is given by

$$e = Blv \sin \theta$$

(i) Here $B = 1 \text{ Wb/m}^2$, $l = 0.5 \text{ m}$, $v = 50 \text{ m/sec}$.
and $\theta = 90^\circ$

Hence $e = 1 \times 0.5 \times 50 \times 1 = 25 \text{ volts Ans.}$

(ii) Here $\theta = 30^\circ$

Hence $e = Blv \sin \theta$
 $= 1 \times 0.5 \times 50 \sin 30^\circ$
 $= 25 \times \frac{1}{2} = 12.5 \text{ volts Ans.}$

(iii) Here $\theta = 0$ since $\sin 0^\circ = 0$

Hence $e = 0 \text{ Ans.}$

Example ii.2: A square coil of 20 cms side and with 200 turns is rotated at a uniform speed of 1000 rpm about an axis at right angles to a uniform magnetic field having a flux

density of 0.5 Wb/m^2 . Determine the instantaneous value of the induced e.m.f. when the plane of the coil is (i) at right angles to the field (ii) at 30° to the field and (iii) in the plane of the field.

Solution. The velocity of the coil

$$\frac{2\pi r \times 1000}{60} = 10.467 \text{ m/sec.}$$

where $r = 10 \text{ cms}$ or 0.1 m

(i) The voltage induced for conductor is $Blv \sin \theta$

Here θ is the angle between the normal to the plane of the coil and the magnetic field

(i) In the first case plane of the coil is at right to the field therefore angle $\theta = 0$ and voltage induced is zero. **Ans.**

(ii) Plane of the coil is at 30° to the field. Hence the angle between normal to the plane and magnetic field is $90 - 30 = 60^\circ$

Hence induced voltage for 200 turns or 400 conductors, $400 Blv \sin 60^\circ$

$$400 \times 0.5 \times 0.2 \times 10.467 \times 0.866 = 362.6 \text{ volts Ans.}$$

(iii) The plane of the coil is in the plane of field i.e. normal to the plane of the coil is normal to the field and hence $\theta = 90^\circ$ and induced voltage.

$$400 \times 0.5 \times 0.2 \times 10.467 \times 1 = 418.7 \text{ volts Ans.}$$

Example ii.3: An airplane has 6.1 m wing span, flies at 800 km/hr . The vertical component of the magnetic flux density of the earth's magnetic field is $50 \mu\text{T}$. Determine the emf. induced between the wing tips.

Solution. The e.m.f. induced between the wing tips Blv

Here $B = 50 \mu\text{T}$, $l = 6.1 \text{ m}$

and $v = \frac{800 \times 1000}{3600} = 222.2 \text{ m/sec}$

Hence e.m.f. induced $= 50 \times 10^{-6} \times 6.1 \times 222.2 = 67.7 \text{ mV Ans.}$

Example ii.4: The total flux at the end of a long bar magnet is $300 \mu\text{Wb}$. The end of the magnet is withdrawn through a 500 turn coil in $1/10$ of a sec. What is the e.m.f. generated across the terminals of the coil.

Solution. e.m.f. generated $= N \frac{d\phi}{dt} = 500 \times \frac{300 \times 10^{-6}}{1/10}$
 $= 5 \times 3 \times 10^{-1} = 1.5 \text{ volt Ans.}$

Example ii.5: A circular iron core has cross sectional area of 5 cm^2 and length of magnetic path 50 cms . It has two coils A and coil B. Coil A has 200 turns and B 500 turns and the current in coil A is changed from 0 to 15 A in $\frac{1}{10}$ sec. Determine the emf induced in coil B. μ_r for the magnetic material is 250.

Solution. The total mmf due to coil A $200 \times 15 = 3000 \text{ AT}$

$$H = \frac{MMF}{\text{length}} = \frac{3000}{0.5} = 6000 \text{ AT/m}$$

$$B = \mu_0 \mu_r H = 4 \pi \times 10^{-7} \times 250 \times 6000$$

$$= 18840 \times 10^{-4} = 1.884 \text{ Wb/m}^2$$

Therefore, $\phi = BA = 1.844 \times 5 \times 10^{-4} = 9.42 \times 10^{-4}$ Wb

Hence induced emf in coil B

$$N \frac{d\phi}{dt} = 500 \times \frac{9.42 \times 10^{-4}}{1/10}$$

$$= 5 \times 9.42 \times 10^{-1} = 4.7 \text{ volts Ans.}$$

Example ii.6: A conductor 0.5 m long is placed in a uniform magnetic field of flux density 0.12 T. If the conductor carries a current of 15 A, determine the force on the conductor.

Solution. Force on conductor Bl

$$= 0.12 \times 15 \times 0.5 = 0.9 \text{ Newton}$$

Example ii.7: Determine the force per metre run between single phase bus bars (i) normally (ii) under steady short circuit condition. The normal load is 10 MVA at 15 kV and the effective impedance 10%. The bus bars are arranged 30 cms apart.

Solution. The force between two current carrying conductors is given by

$$F = \frac{\mu_0}{2\pi} \cdot \frac{I_1 I_2 l}{r}$$

where l is the length of the conductor which we will take use as 1 m as force per meter is required and r is the distance of separation which is given to be 30 cms. Since it is a single phase bus bar system $I_1 = I_2 = I$

$$I = \frac{10 \times 1000}{15} = 666.67 \text{ A}$$

$$\text{Hence force per metre} = \frac{2 \times 10^{-7} \times 666.67^2}{0.3} \text{ N} = 0.296 \text{ Newton.}$$

Since the effective impedance is 10% therefore the short circuit current will be 10 times the normal current. Hence force per metre will be 100 times that under normal condition i.e. 29.6 Newton. **Ans.**

Since the currents are flowing in opposite direction, there will be force of repulsion.

Example ii.8: The flux ϕ linked by a coil of 100 turns varies during the period T of one complete cycle as follows: from time $t = 0$ to $t = \frac{T}{2}$, $\phi = \phi_m (1 - 4t/T)$ and from $t = \frac{T}{2}$ to $t = T$, $\phi = \phi_m \left(\frac{4t}{T} - 3 \right)$. If T be $\frac{1}{50}$ sec. and $\phi_m = 0.02$ Wb, determine the maximum value of the induced emf.

Solution. Since $\phi = \phi_m (1 - 4t/T)$ $0 \leq t \leq T/2$

$$\text{and } \phi = \phi_m \left(\frac{4t}{T} - 3 \right) \quad \frac{T}{2} \leq t \leq T$$

Since the flux is a time function and the coefficient $\frac{4}{T}$ is common in the complete duration.

We take the former

$$e = -N \frac{d\phi}{dt} = N \cdot \frac{4}{T} \phi_m = 100 \times \frac{4}{1/50} \times 0.02 = 400 \text{ V Ans.}$$

Example ii.9: Calculate the inductance of a toroid 25 cm mean diameter and 6.25 cm² circular cross-section wound uniformly with 1000 turns of wire ; also the emf induced when a current increasing at the rate of 200 A/sec flows in the winding.

Solution. We know that

$$\begin{aligned} L &= \mu_0 \frac{A}{l} N^2 \text{ Henry} \\ &= \frac{4\pi \times 10^{-7} \times 6.25 \times 10^{-4} \times 1000^2}{\pi \times 25 \times 10^{-2}} \\ &= 1 \text{ mH Ans.} \end{aligned}$$

The voltage induced $L \frac{di}{dt} = -10^{-3} \times 200 = -0.2 \text{ V Ans.}$

Here minus sign as the current is increasing.

Example ii.10: An air cored coil has 1000 turns with an inductance of 120 mH. Two hundred turns are removed from the coil and a steel core is placed around the coil μ_r for steel core is 75. Determine the new value of inductance.

Solution. Since

$$L \propto N^2$$

and

$$L \propto \mu_r$$

Hence new value of inductance = $120 \times \left(\frac{800}{1000}\right)^2 \times 75 = 5.76 \text{ Henry.}$

Example ii.11: The current in an ignition coil is 3A. The inductance of the coil is 10 H. If the stored energy is uniformly dissipated in a spark plug in 20 m sec ; What is the power delivered to the spark plug ? If the voltage across the spark plug is 20 kV, determine the current.

Solution. The energy stored in the inductor is

$$\frac{1}{2} Li^2 = \frac{1}{2} \times 10 \times 3^2 = 45 \text{ Joule or watt. sec.}$$

Since the energy dissipated is in 20 m sec, hence power dissipated = $\frac{45}{20 \times 10^{-3}} = 2250$

watts

If the voltage is 20 kV, the current is $\frac{2250}{20,000} = 0.1125 \text{ A.}$

Example ii.12: There are two coils having coefficient of coupling 0.8 . The current in coil 1 is 3 A and the total flux 0.4 mWb. The voltage induced in coil 2 is 85 volts when the current in coil is reduced to zero in 3 m sec. The no of turns in coil 1 is 300. Determine L_1 , L_2 , M and N_2 .

Solution. By definition $L_1 = \frac{N_1 \phi_1}{I_1} = \frac{300 \times 0.4 \times 10^{-3}}{3} = 40 \text{ m/H}$

Now $M \frac{di}{dt} = V_2 = 85 = M \frac{3}{3 \times 10^{-3}} = 1000 M$

or $M = 0.085 \text{ H}$

$$\begin{aligned} \text{Now} \quad M &= K\sqrt{L_1L_2} \\ 85 &= 0.8\sqrt{40 \times L_2} \\ 106.25 &= \sqrt{40L_2} \quad \text{or} \quad L_2 = 282 \text{ mH} \end{aligned}$$

The flux that links the coil 2 is

$$\begin{aligned} \phi_{21} &= K\phi_1 \\ &= 0.8 \times 0.4 = 0.32 \text{ mWb} \end{aligned}$$

$$\text{Now} \quad M = \frac{N_2\phi_{21}}{i_1} = \frac{N_2 \times 0.32}{3} = 85$$

$$\text{or} \quad N_2 = \frac{85 \times 3}{0.32} = 79.7 \text{ turns Ans.}$$

Example ii.13: In a pair of coupled coils, coil 1 has 600 turns and carries a current of 2.5 A and its fluxes ϕ_{11} and ϕ_{21} are 0.4 and 0.8 m Wb respectively. If coil 2 has 2000 turns determine L_1 , L_2 , M and K .

Solution. The total flux due to coil is

$$\phi_1 = \phi_{11} + \phi_{21} = 0.4 + 0.8 = 1.2 \text{ mWb}$$

$$\text{self inductance of coil} \quad L_1 = \frac{N_1\phi_1}{I_1} = \frac{600 \times 1.2 \times 10^{-3}}{2.5} = 288 \text{ mH.}$$

$$\text{The coupling coefficient is } \frac{\phi_{21}}{\phi_1} = \frac{0.8}{1.2} = 0.67$$

$$\text{The mutual inductance} \quad M = \frac{N_2\phi_{21}}{I_1} = \frac{2000 \times 0.8}{2.5} = 640 \text{ mH}$$

$$\text{and hence} \quad K = \frac{M}{\sqrt{L_1L_2}} = 0.67$$

$$\sqrt{L_1L_2} = \frac{M}{0.67}$$

$$\text{or} \quad \sqrt{288L_2} = \frac{640}{0.67}$$

$$L_2 = 3.168 \text{ H Ans.}$$

Example ii.14: Two identical coils of 1000 turns each X and Y lie in parallel planes such that 60% of the flux produced by one coil links the other. A current of 5 A in X produces in it a flux of 0.05 mWb. If the current in X changes from 6 A to -6 A in 10 m sec. What is the emf induced in coil Y. Determine L_x , L_y and M .

Solution. $\phi_x = 0.05 \text{ mWb}$

$$L_x = \frac{N_x\phi_x}{I_x} = \frac{1000 \times 0.05 \times 10^{-3}}{5} = \frac{0.05}{5} = 10 \text{ mH}$$

Since the two coils are identical $L_x = L_y = 10 \text{ mH Ans.}$

$$\text{Since} \quad K = 0.6 = \frac{M}{\sqrt{L_1L_2}} = \frac{M}{10} \quad \text{or} \quad M = 6 \text{ mH Ans.}$$

Voltage induced in coil y $M \frac{di}{dt} = 6 \times 10^{-3} \frac{12}{10 \times 10^{-13}} = 7.2 \text{ volt Ans.}$

Example ii.15: Two coupled coils with $L_1 = 0.5H$ and $L_2 = 1.0 H$ have a co-efficient of coupling 0.8 and the no. of turns in coil 2 is 1500. If the current in coil 1 is $i_1 = 20 \sin 314 t$ amp, determine the voltage across coil 2 and the maximum flux set up by the coil 1.

Solution. Since $M = k\sqrt{L_1 L_2} = 0.8\sqrt{0.5 \times 1.0} = 0.5657 H$

Now voltage across coil 2 is

$$\begin{aligned} v_2 &= M \frac{di_1}{dt} = 0.5657 \frac{d}{dt} (20 \sin 314t) \\ &= 0.5657 \times 20 \times 314 \cos 314t \\ &= 3552.5 \cos 314t \text{ Ans.} \end{aligned}$$

$$v_2 = N_2 \frac{d\phi_{21}}{dt} = 1500 \frac{d\phi_{21}}{dt} = 3552.5 \cos 314t$$

or $d\phi_{21} = 2.37 \cos 314t dt$

$$\phi_{21} = \frac{2.37}{314} \sin 314t = 0.0075 \sin 314t$$

or $\phi_{21} = 7.5 \text{ mWb maximum value Ans.}$

Example ii.16: Determine the hourly loss of energy in a specimen of iron the hysteresis loop of which is equivalent in area of $250 J/m^3$. Frequency 50 Hz, density of iron 7.5 and weight 10 kg.

Solution. Density is 7.5 which means 7.5 gm/cm^3

or $\frac{7.5 \times 10^6}{10^3 \times m^3} = \text{kg/m}^3 = 7500 \text{ kg/m}^3$

Hence volume of the specimen $= \frac{10}{7500} = 1.33 \times 10^{-3} \text{ m}^3$

Therefore, iron loss per cycle $= 250 \times 1.33 \times 10^{-3} = 333.33 \times 10^{-3} \text{ Joule}$

Therefore, loss per second $= 333.33 \times 10^{-3} \times 50 = 16.67 \text{ Joules}$

Hence hourly loss $16.67 \times 3600 = 60,000 \text{ Joules Ans.}$

Example ii.17: The maximum flux density in a hysteresis loop is 1.5 Wb/m^2 . The abscissa is scaled as $1 \text{ cm} = 15 \text{ A/cm}$ Ordinate is $1 \text{ cm} = 1 \text{ Wb/m}^2$. The area of the hysteresis loop is 0.6 cm^2 . Determine the hysteresis loss if 1500 cm^3 of the material is subjected to an alternating flux density of 1.5 Wb/m^2 at 50 Hz.

Solution. The area of the loop 0.6 cm^2 gives the hysteresis loss per cycle

Now $1 \text{ cm} = 15 \text{ AT/cm}$ or 1500 AT/m

and $1 \text{ cm} = 1 \text{ Wb/m}^2$

Therefore, 1 cm^2 area of loop equals $1500 \times 1 = 1500 \text{ J/m}^3/\text{cycle}$

Since the area of the loop given is 0.6 cm^2

Hence hysteresis loss $= 1500 \times 0.6 \text{ J/m}^3/\text{cycle} = 900$

Volume of material 1500 cm^3 or $1.5 \times 10^{-3} \text{ cum}$

Hence, hysteresis loss per cycle $= 900 \times 1.5 \times 10^{-3}$
 $= 1350 \times 10^{-3} \text{ Joules}$

Therefore at 50 Hz the loss per second

$$1.35 \times 50 = 67.5 \text{ J/sec or } 67.5 \text{ watts.}$$

Example ii.18: The hysteresis loss in a sample of iron is found to be 4.9 W/kg at a frequency of 50 Hz and maximum flux density of 1 Wb/m². (a) Determine the coefficient η in the expression for loss in Joule/m³/cycle = $\eta B^{1.7}$. The density of iron 7.5 (b) Calculate the loss per kg at 25 Hz and 1.8 Wb/m².

Solution. The hysteresis loss J/m³/cycle is

$$\frac{4.9 \times 7500}{50} = 735$$

and this should equal $\eta(B)^{1.7} = \eta(1)^{1.7} = 735$

Hence $\eta = 735$ Ans.

(ii) To find out loss per kg at 25 Hz and 1.8 Wb/m²

$$4.9 \times \frac{25}{50} \times (1.8)^{1.7} = 6.65 \text{ watt/kg.}$$

Example ii.19: Two coils with N_1 and N_2 turns are wound on the same magnetic bar.

Show that the mutual inductance between the two coils is $M = \frac{N_1 N_2 K}{R}$ where R is the reluctance of the magnetic circuit.

Solution. $M = K \sqrt{L_1 L_2}$ and $L_1 = N_1^2 \mu_0 \frac{A}{l}$ and $L_2 = N_2^2 \mu_0 \frac{A}{l}$

or $L_1 = \frac{N_1^2}{R}$ and $L_2 = \frac{N_2^2}{R}$

Hence $M = K \cdot \frac{N_1 N_2}{R}$ Ans.

PROBLEMS

- ii.1. State and explain Faraday's laws of electromagnetic induction.
- ii.2. State and explain Lenz's law.
- ii.3. State and explain laws of electromagnetic force. Explain clearly how these forces are developed when two current carrying conductors have currents (i) same direction (ii) opposite direction.
- ii.4. Develop an expression for force developed between two parallel current carrying conductors and hence define one ampere current.
- ii.5. State and explain Fleming's right hand and left hand rules.
- ii.6. Develop an expression for force between two long parallel current carrying conductors.
- ii.7. Explain what you mean by dynamically induced emf. Develop an expression for the induced emf.
- ii.8. Explain what you mean by statically induced emf. Develop an expression for the induced emf. Hence develop an expression for induced emf for harmonically varying magnetic field.
- ii.9. Define and explain what you mean by self inductance of coil. How do you compare the inductance of an air cored coil and an iron cored coil?
- ii.10. Develop an expression for inductance of a coil in terms of its physical parameters. Explain the variation of inductance of an iron cored coil as a function of current through the coil.
- ii.11. Explain what you mean by mutual inductance between coils. Starting from first principles develop an expansion for mutual inductance.

- ii.12. Explain coefficient of magnetic coupling and develop an expression for the same. Discuss its physical significance.
- ii.13. Explain with neat diagram the process of Hysteresis in a magnetic material. How do you obtain magnetisation characteristic of a magnetic material from the hysteresis loops.
- ii.14. Develop an expression for hysteresis loss in a magnetic material. Discuss various factors which can be employed to reduce this loss.
- ii.15. Explain with the help of neat diagram eddy current loss in a magnetic material. Discuss various methods to reduce this loss.
- ii.16. The total flux at the end of a long bar magnet is $300 \mu\text{Wb}$. The end of the magnet is withdrawn through a 1000 turn coil in $1/100$ th of a sec. Determine the voltage induced across the coil.
[Ans. 30 V]
- ii.17. A coil carries a current of 60 mA and has an inductor of $300 \mu\text{H}$. Determine flux in the coil.
[Ans. $360 \mu\text{Wb}$]
- ii.18. A particular coil has 500 turns and an inductance of 120 mH. How many turns should be removed to get an inductor of 95 mH, keeping everything else unchanged ?
[Ans. 88 turns]
- ii.19. A 4-pole generator is running at 1800 rpm. The generated emf. in each conductor is 10 mV. Determine the flux required at each pole.
[Ans. $83.3 \mu\text{Wb}$]
- ii.20. A 1200 turn coil is wound on a former having a rectangular cross-section of $5 \text{ cm} \times 2.5 \text{ cm}$ and 10 cms long. The current in the coil is 200 mA. Determine the inductance of the coil and the energy stored in the magnetic field.
[Ans. 23 mH, 460 kJ]
- ii.21. Two coils of 1250 and 140 turns respectively are wound on a common iron magnetic circuit of reluctance 160000 units. Determine the mutual inductance. Neglect leakage flux
[Note: $M = \frac{N_1 N_2 K}{R}$, Take $k = 1$]
[Ans. 1.1 H]
- ii.22. Two coils having 30 and 600 turns respectively are wound side by side on a closed iron circuit of section 100 cm^2 and mean length 150 cms. (a) Determine the mutual inductance between the coils if the permeability of iron is 2000.
(b) A current in the first coil increases uniformly from zero to 10 A in 10 m/sec, determine the emf induced in the other coil.
[Ans. 0.302 H, 302 V]
- ii.23. A circuit has 1000 turns enclosing magnetic circuit 20 cm^2 in section. With 4 A the flux density is 1 Wb/m^2 and with 9 A it is 1.4 Wb/m^2 . Determine the mean value of the inductance between these current limits and the induced emf. if the current is decreased uniformly from 9A to 4 A in 50 m sec.
[Ans. 0.16 H, 16 V]
- ii.24. A magnet has a residual magnetism in the air gap of 1.3 T. The pole face at the air gap is a square section $5 \text{ cm} \times 5 \text{ cm}$. How long (time) must a conductor be moved through the air gap to produce a generated emf of 10 mV. Assume that there is no fringing in the air gap.
[Ans. 0.335 sec]

REFERENCE

1. Langsdorf A.S., *Theory of alternating current Machinery*, McGraw Hill 1953.
2. Wadhwa C.L., *Network Analysis*, New Age International Publishers 2004.
3. E. Normon Lurch, *Electric Circuit Fundamentals*, Prestice Hall.
4. Fitzgerald A.E. and Kingsley C., *Electric Machinery*, Mc Graw Hill, 1961.
5. V. Del Toro, *Electrical Engineering Fundamental*, Prentice Hall.
6. Sen P.C., *Principles of Electric Machinery and Power Electric*, John Willaey, 1989.

CHAPTER

1

A-C Circuits

1.1 INTRODUCTION

Network theory, in general, deals into three components, the network, usually consisting of a suitable combination of R , L and C , the source and the response. Mostly, it is desirable that whatever is the waveform of the source, same waveform should appear in the response (Exceptions to be ignored). We have various waveforms viz. square, triangular, trapezoidal, sinusoidal etc. Out of all these, if the circuit has resistance only, one can use any of the waveforms mentioned above and the response (v - i relation) will have the same waveform as the excitation (source). However, with L and C as the element, it is only sinusoidal waveform which satisfies the requirement of identical waveforms for source and response. If the source is voltage source the current through the inductor is proportional to the integral of the voltage wave and for the capacitor, it is the derivative of the voltage wave. It is a very useful and important property of sine waves that both it's derivative and integrals are also sinusoidal. The basis for standardization on the sine wave thus comes from both physics and calculus. Also, it is very easy to generate the sine waves using rotating machines and transmit and distribute electric energy using transformers. We next illustrate that a uniform circular motion or simple harmonic motion is a sinusoidal variation.

Sine wave is the basic waveform of a.c. circuit theory and it is necessary to learn how to handle such waves.

Let us relate a uniform circular motion or rotation to a sinusoidal wave form. We consider a rotating voltage/current phasor that has a length V_m/I_m and is coincident along x -axis Fig. 1.1. We start counting time and rotate the phasor anti-clockwise and at various instant of time we take the projection of the rotating phasor along y -axis.

At $t = 0$, the projection is zero and hence we plot a point on the right hand side along $t(\theta)$ axis. After certain time say t the phasor rotates through an angle θ and there is some finite projection along y -axis, mark this on the right hand side along $t(\theta)$ axis as shown in Fig. 1.1. As we rotate the phasor further when $\theta = 90^\circ$ the value of the projection is V_m/I_m . Mark it on the right hand side along $t(\theta)$ axis as shown. Rotate phasor further and obtain the projection along y -axis, the projections decreases beyond 90° and continues to be along $+y$ axis till $\theta = 180^\circ$ when projection is zero.

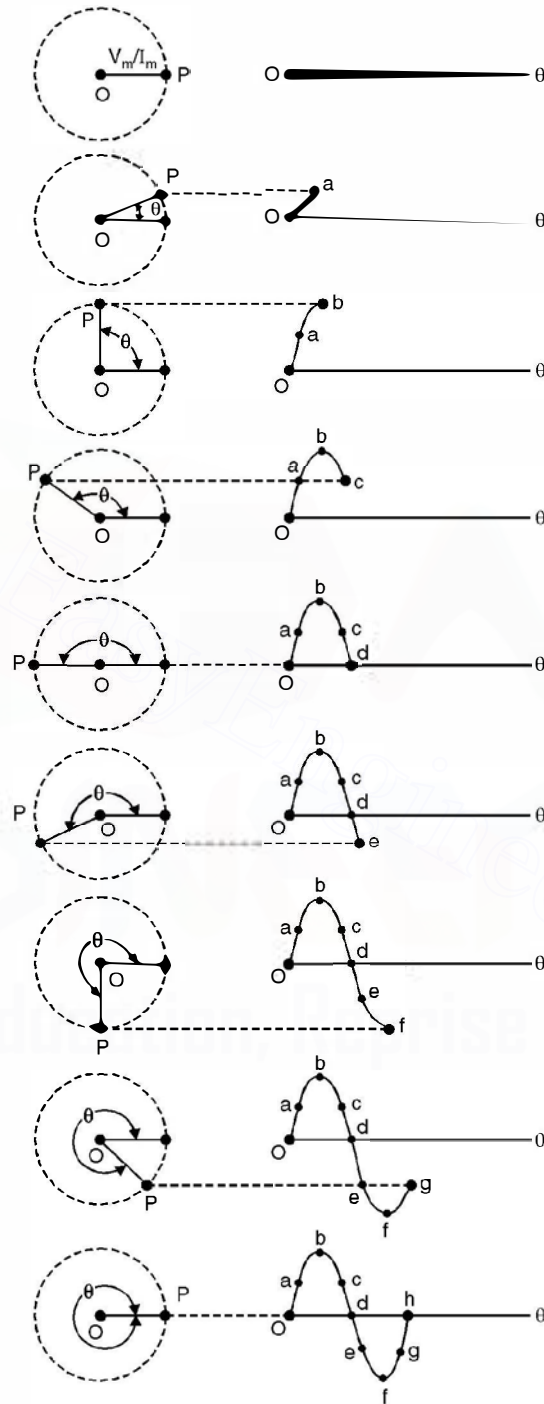

Fig. 1.1

Similarly if we rotate the phasor further through 2π radian or 360° or one cycle, we obtain a complete sine wave as shown in Fig. 1.1. Thus, if the speed of rotation is f revolutions/sec the phasor has a frequency of f hertz (Hz). Hence the angular velocity is $\omega = 2\pi f$ rad/sec.

If the instantaneous value of time at any instant of rotation is t seconds the total angle in radians from time zero upto that point is

$$2\pi ft = \omega t$$

The concept of rotating phasor is a function of time, we may substitute $2\pi ft$ or ωt for θ in the equation.

$$V = V_m \sin \theta$$

and now therefore, the instantaneous voltage in terms of time is

$$V = V_m \sin 2\pi ft = V_m \sin \omega t \quad \dots(1.1)$$

when equation 1.1 is used, the axis of the waveform is not θ but time t .

1.2 PHASE

A sinusoidal waveform having a displacement of θ to the left is shown in Fig. 1.2(a) which means that at $t = 0$ the phasor has an initial displacement of θ in counterclockwise direction. Therefore, the initial instantaneous value of voltage/current at time $t = 0$ is

$V = V_m \sin \theta$ putting $\omega t = 0$. This shift of the waveform is called a phase displacement and the angle θ is called phase angle. Fig. 1.2 (b-d) show different phase displacements of the same sine wave. The sine wave at 'a' is said to be leading the wave at 'b' as

$$V_a = V_m \sin (\omega t + \theta) \text{ and at } b$$

$$V_b = V_m \sin (\omega t - \theta)$$

Example 1.1. The equation for a voltage wave is $v = 0.02 \sin (4000t + 30^\circ)$. Find the frequency, the instantaneous voltage when $t = 320 \mu$ sec. What is the time represented by 30° phase difference?

Solution: The general expression for voltage is given as

$$V = V_m \sin (2\pi ft + \theta)$$

here $2\pi f = 4000$ or $f = \frac{4000}{2\pi} = 637 \text{ Hz.}$

When $t = 320 \mu \text{ sec.}$

$$v = 0.02 \sin \left(4000 \times 320 \times 10^{-6} \times \frac{180}{\pi} + 30^\circ \right)$$

$$v = 0.02 \sin (73.3 + 30)$$

$$= 0.02 \sin (103.3)$$

$$= 0.0195 \text{ volt}$$

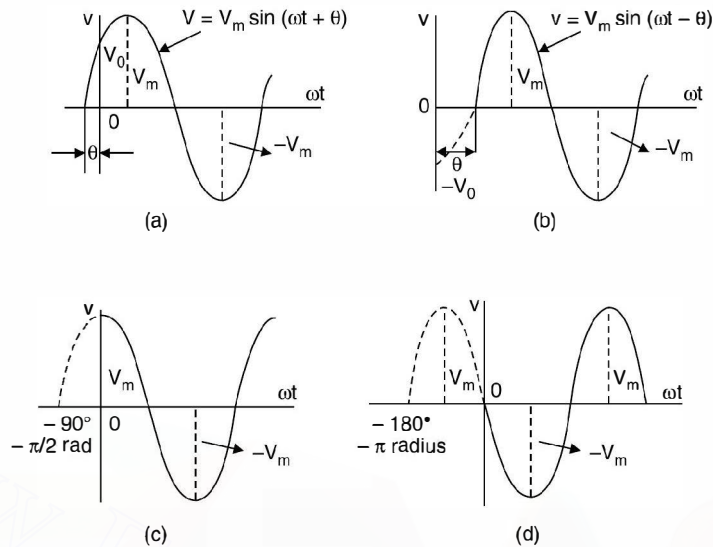

Fig. 1.2 Displaced sinusoidal voltage waveforms:

- (a) displacement of θ to the left, (b) Displacement of θ to the right,
 (c) Displacement to the left of 90° ($\pi/2$ radians), (d) Displacement of 180° (π radians).

The time of 1 cycle is

$$\frac{1}{f} = \frac{1}{637}$$

which is equal to 360° electrical degrees. Hence for 30° the time taken is

$$\frac{30}{360} \times \frac{1}{637} \text{ sec} = 0.131 \text{ m sec} \quad \text{Ans.}$$

1.3 THE AVERAGE VALUE OF A WAVEFORM

In a.c. circuit applications we are interested in finding out the average value of a waveform, that wave could be sinusoidal, triangular trapezoidal or any other shape.

The average value of a cycle of a waveform is the area under the waveform divided by the length of one cycle.

Mathematically,

$$V_{av} = \frac{1}{T} \int_0^T v \, dt = \frac{1}{2\pi} \int_0^{2\pi} v \, dt \quad \dots(1.2)$$

where T is the length of one cycle.

We first consider average value of sinusoidal waves for which we consider the following different shapes.

These are all sine waves In (a) since it is a full sine wave, the total area under the curve is zero as half of it is above ωt axis and equal half is below ωt -axis and hence the average area of the curve is zero and hence over the complete sine wave the average value is zero.

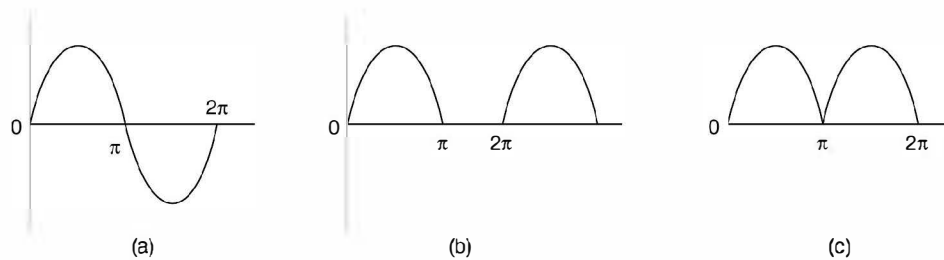

Fig. 1.3 (a) Full sine wave (b) Half-rectified wave (c) Full rectified wave

However, in Fig. 1.3(b) the average value is

$$\begin{aligned} V_{av} &= \frac{1}{2\pi} \int_0^{\pi} V_m \sin \omega t \, d\omega t \\ &= \frac{1}{2\pi} \left[-V_m \cos \omega t \right]_0^{\pi} \\ &= \frac{-V_m}{2\pi} [\cos \pi - \cos 0] \\ &= \frac{V_m}{\pi} \end{aligned}$$

For Fig. 1.3(c) the average value is just double of what we have for a half wave rectified sine wave as over the same period 2π , the area under the curve is double of what we have for the half wave.

i.e., For full rectified wave, average value is $\frac{2V_m}{\pi}$

Consider a non-sinusoidal wave shown in Fig. 1.4 and find the average value of the wave for one half cycle.

Since the wave has a trapezoidal shape the area under the curve is

$$\frac{1}{2} (\pi + \pi - 2\alpha) F_m$$

$$\text{Hence Average Value} = \frac{2(\pi - \alpha)}{2\pi} F_m$$

If $\alpha = 0$

Average Value is F_m

If $\alpha = \frac{\pi}{6}$

$$\text{Average Value is } \frac{(\pi - \pi/6)}{\pi} F_m = \frac{5}{6} F_m$$

Similarly if $\alpha = \frac{\pi}{2}$, the average value is

$$\frac{\pi - \pi/2}{\pi} F_m = \frac{F_m}{2}$$

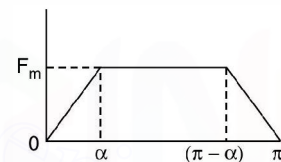

Fig. 1.4 Trapezoidal wave

1.4 THE EFFECTIVE OR RMS VALUE OF A WAVE

The *rms* or effective value of a wave is defined as that d.c. value which when allowed to flow through a particular resistance for a certain time would produce the same heating effect as that produced by the wave. This is represented mathematically as

$$I_{rms} = I_{eff} = \sqrt{\frac{1}{T} \int_0^T i^2 dt}$$

As the name *rms* (root of mean of the squared values) suggests that we have to take the square of the various ordinates and find the area of the squared wave over the period T and find the mean value of this quantity and then obtain its square root. This is the effective value.

We again take first, various sinusoidal waves as shown in Fig. 1.3(a) to (c) and find out their *rms* values Fig. 1.3(a).

As per the definition we have first to express the wave as per its instantaneous value as every instantaneous value is to be squared and then area under this curve is to be obtained. Now, for this sine wave

$$i = I_m \sin \omega t$$

Since the wave is to be squared, the negative part of the wave during π to 2π would also become positive and hence *rms* value over the complete cycle will not be zero.

Hence

$$\begin{aligned} I_{rms} &= \sqrt{\frac{1}{2\pi} \int_0^{2\pi} i^2 d\omega t} \\ &= \sqrt{\frac{1}{2\pi} \int_0^{2\pi} I_m^2 \sin^2 \omega t d\omega t} \\ &= \sqrt{\frac{I_m^2}{2\pi} \int_0^{2\pi} \frac{1 - \cos 2\omega t}{2} d\omega t} \\ &= I_m \sqrt{\frac{1}{4\pi} \left(\omega t - \frac{\sin 2\omega t}{2} \right)_0^{2\pi}} \\ &= I_m \sqrt{\frac{2\pi}{4\pi}} = \frac{I_m}{\sqrt{2}} \end{aligned}$$

For Fig. 1.3(b) where it is a half rectified sine wave, the *rms* value over the complete cycle will be

$$\begin{aligned} &\sqrt{\frac{I_m^2}{2\pi} \int_0^\pi \left(\frac{1 - \cos 2\omega t}{2} \right) d\omega t} \\ &= \frac{I_m}{2} \end{aligned}$$

i.e. *rms* value of half rectified sine wave is $\frac{1}{2}$ of its peak value.

For Fig. 1.3(c) since it is a full rectified wave and the square of each ordinate will be similar to the full sine wave, the *rms* value will be same i.e. $\frac{I_m}{\sqrt{2}}$.

Let us find out *rms* value of the wave shown in Fig. 1.4. The wave can be expressed mathematically as

$$\begin{aligned} f(\theta) &= \frac{F_m}{\alpha} \theta & 0 < \theta \leq \alpha \\ &= F_m & \alpha \leq \theta \leq \pi - \alpha \\ &= -\frac{F_m}{\alpha} \theta & (\pi - \alpha) \leq \theta \leq \pi \end{aligned}$$

Since the area under the squared ordinate in the interval 0 to α and $(\pi - \alpha)$ to α is same we have the *rms* value as

$$\begin{aligned} i_{rms} &= \sqrt{\frac{1}{\pi} \left[2 \int_0^{\alpha} \frac{F_m^2}{\alpha^2} \theta^2 d\theta + \int_{\alpha}^{\pi-\alpha} F_m^2 d\theta \right]} \\ &= \sqrt{\frac{F_m^2}{\pi} \left[2 \left(\frac{\theta^3}{3\alpha^2} \right)_0^{\alpha} + (\theta)_{\alpha}^{\pi-\alpha} \right]} \\ &= \sqrt{\frac{F_m^2}{\pi} \left[\frac{2\alpha}{3} + \pi - \alpha - \alpha \right]} \\ &= \sqrt{\frac{F_m^2}{\pi} \left(\pi - \frac{4}{3} \alpha \right)} \\ &= F_m \sqrt{\left(\pi - \frac{4}{3} \alpha \right) / \pi} \end{aligned}$$

now when $\alpha = 0$ i.e. it is a d.c. wave

$i_{rms} = F_m$ which is an expected value as the *rms* value of a d.c. wave is the d.c. value itself. Similarly the average value of a d.c. wave is the value of the d.c. wave.

If $\alpha = \frac{\pi}{6}$

$$\begin{aligned} i_{rms} &= F_m \sqrt{\left(\pi - \frac{4}{3} \frac{\pi}{6} \right) / \pi} \\ &= \sqrt{\frac{7}{9}} F_m \end{aligned}$$

when

$$\begin{aligned} \alpha &= \frac{\pi}{2} \\ i_{rms} &= F_m \sqrt{\left(\pi - \frac{4}{3} \cdot \frac{\pi}{2} \right) / \pi} = \frac{F_m}{\sqrt{3}} \end{aligned}$$

1.4.1 Form Factor

It is defined as the ratio of *rms* value of a wave and the average value of the wave.

i.e. Form factor = $\frac{\text{rms value of the wave}}{\text{Average value of the wave}}$

For a sinusoidal wave

$$\begin{aligned}\text{Form factor} &= \frac{V_m}{\sqrt{2}} \cdot \frac{\pi}{2V_m} \\ &= 1.11\end{aligned}$$

1.4.2 Peak Factor or Crest Factor

It is the ratio of the peak value of the wave to its *rms* value.

For a sinusoidal wave

$$\text{Peak factor} = \frac{V_m}{V_m/\sqrt{2}} = \sqrt{2} = 1.414$$

It is sometimes misunderstood that the operating voltages e.g. 110 V, 220 V, 132 KV are used because of form factor which is 1.11 i.e. multiple of 11. In fact these voltages have been standardized as standardization has its own economic and operating advantages. In fact there are many other operating voltages e.g. 400 V, 400 KV, 765 KV which are not multiple of 11. So it is the standardization which has selected certain voltages as operating voltages.

Form factor does not have much of significance except when two wave forms one with higher form factor when applied to magnetic materials, produces higher hysteresis loss per loop as compared to one with lower form factor.

Crest factor has an indication of electric stresses developed in insulating material as the stresses are a function of the peak value of the wave.

1.5 PHASOR DIAGRAM

Consider Fig. 1.5 which shows time waves of a sinusoidal current waveform lagging a sinusoidal voltage waveform by θ degrees. The same aspect can be represented by two phasors rotating counter clockwise at the angular velocity ω .

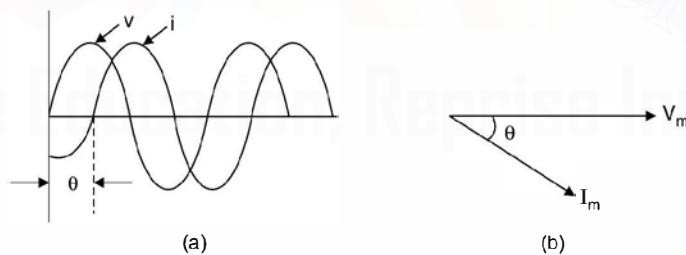

Fig. 1.5 (a) *V-i* sinusoidal wave (b) Phasor representation of (a)

At each point on the time waveform, the angle of current lag is θ because the angle between the phasors V_m and I_m is at all time θ . Therefore, either the time waveform of the rotating phasors or the phasor diagram, can be used to describe the system. Since both the diagrams, the time diagram and the phasor diagram convey the same information, the phasor diagram being much more simpler, it is used for an explanation in circuit theory analysis. Since electrical data is given in terms of *rms* value, we draw phasor diagram with phasor values as *rms* rather than peak value used so far.

1.5.1 Phasor Algebra

Consider a phasor V in Fig. 1.6. This can be represented mathematically in the following ways :

$$V = V_x + jV_y \text{ (Cartesian Co-ordinates)}$$

$$V = |V| \angle \theta \text{ in polar coordinates.}$$

Here V_x is the component of V along x -axis and V_y is the component of V along y -axis and j is an operator which when multiplied to a phasor rotates the phasor 90° anticlockwise and

$$j = \sqrt{-1} \quad \text{or} \quad j^2 = -1$$

Addition and subtraction of phasors is very simple in cartesian coordinates as each phasor is to be decomposed into two components, one along x -axis and the other along y -axis and algebraic addition or subtraction can be carried out with ease.

Multiplication and division is very simple in polar coordinates. As the multiplication of various phasor equals the multiplication of magnitude of individual phasor and the angle is the algebraic sum of the phase angle of individual phasors i.e.

$$\begin{aligned} V &= |V_1| \angle \theta_1 |V_2| \angle \theta_2 |V_3| \angle -\theta_3 \\ &= |V_1| |V_2| |V_3| \angle \theta_1 + \theta_2 - \theta_3 \end{aligned}$$

Similarly, division of two phasors is the division of the magnitude of the two phasors and the angle is the difference of the angles of the two phasors e.g.

$$V \angle \theta = \frac{V_1 \angle \theta_1}{V_2 \angle -\theta_2} = \left| \frac{V_1}{V_2} \right| \angle \theta_1 + \theta_2$$

Let us now consider phase relations between voltages and currents when sinusoidal voltages are applied to R , L and C elements.

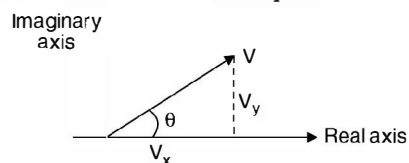

Fig. 1.6 Representation of phasor

1.6 RESISTANCE CONNECTED ACROSS A SINUSOIDAL VOLTAGE

Fig. 1.7 shows resistance connected to a sinusoidal source of V_m as peak voltage

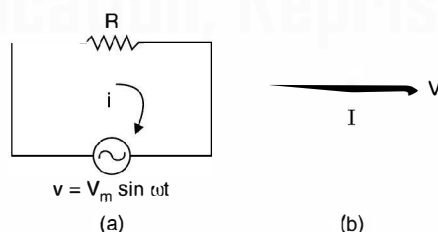

Fig. 1.7 Resistance across a c supply.

The instantaneous value of current in the circuit is

$$\begin{aligned} i &= \frac{v}{R} = \frac{V_m}{R} \sin \omega t \\ &= I_m \sin \omega t \end{aligned}$$

Since the two phasors voltage and current have exactly similar representation except for the magnitude, the two phasors are in phase i.e. they are represented as in Fig. 1.7(b) where V and I are the *rms* values of voltage and current.

Now power

$$\begin{aligned}
 p &= \frac{1}{2\pi} \int_0^{2\pi} vi \, d\omega t \\
 &= \frac{1}{2\pi} \int_0^{2\pi} I_m V_m \sin \omega t \sin \omega t \, d\omega t \\
 &= \frac{V_m I_m}{2\pi} \int_0^{2\pi} \sin^2 \omega t \, d\omega t \\
 &= \frac{V_m I_m}{2\pi} \int_0^{2\pi} \frac{1 - \cos 2\omega t}{2} \, d\omega t \\
 &= \frac{V_m I_m}{4\pi} \left[\omega t - \frac{\sin 2\omega t}{2} \right]_0^{2\pi} \\
 &= \frac{V_m I_m}{4\pi} \cdot 2\pi \\
 &= \frac{V_m I_m}{4\pi} \\
 &= VI
 \end{aligned}$$

Hence average power in a resistive element equals the product of the *rms* voltage and current across and through the resistance respectively.

1.6.1 Inductor Across Sinusoidal Source

Whenever an *ac* source is connected across an inductor a voltage is induced in the inductor and the instantaneous value of this voltage is given by

$$v_L = -L \frac{di}{dt}$$

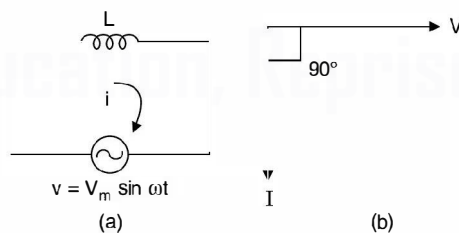

Fig. 1.8

and this voltage opposes the increase in current in the inductor and hence

$$v_L = -v$$

Hence

$$v = L \frac{di}{dt}$$

or

$$di = \frac{v}{L} dt$$

$$\begin{aligned}
 i &= \frac{1}{L} \int V_m \sin \omega t \, dt \\
 &= -\frac{V_m}{L} \frac{\cos \omega t}{\omega} \\
 &= -\frac{V_m}{\omega L} \cos \omega t \\
 &= \frac{V_m}{\omega L} \sin (\omega t - 90^\circ)
 \end{aligned}$$

Since $\frac{V_m}{\omega L}$ dimensionally should be current and it is the ratio of voltage to ωL , therefore, the denominator should be something like resistance in d.c. circuit. The term ωL is known as inductive reactance as it is due to an inductance and we see that the two phasors v and i for an inductor are not identical. If we compare expression for v and i we find that current i lags the voltage exactly by 90° as shown in Fig. 1.8(b).

Now
$$I = \frac{I_m}{\sqrt{2}} \quad \text{and} \quad V = \frac{V_m}{\sqrt{2}}$$

Hence the ratio of the two phasors

$$\begin{aligned}
 \frac{V \angle 0}{I \angle -90^\circ} &= \frac{V_m / \sqrt{2}}{\frac{V_m}{\sqrt{2}} \angle -90^\circ} = \omega L \angle 90^\circ \\
 &= j\omega L \\
 &= jX_L
 \end{aligned}$$

The average power in the circuit.

$$\begin{aligned}
 p &= \frac{1}{2\pi} \int_0^{2\pi} v i \, d\omega t \\
 &= \frac{1}{2\pi} \int_0^{2\pi} V_m \sin \omega t I_m \sin (\omega t - 90^\circ) \, d\omega t \\
 &= \frac{1}{2\pi} \int_0^{2\pi} V_m I_m \sin \omega t \cos \omega t \, d\omega t \\
 &= \frac{1}{2\pi} \cdot V_m I_m \int_0^{2\pi} \frac{\sin 2\omega t}{2} \, d\omega t = 0
 \end{aligned}$$

This shows that the power consumed in a purely inductive circuit is zero.

1.6.2 Capacitor Connected Across Sinusoidal Source

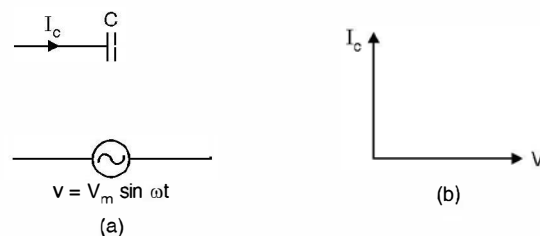

Fig. 1.9

The voltage and current in a capacitor are related as

$$\begin{aligned} i &= C \frac{dv}{dt} \\ &= CV_m \omega \cos \omega t \\ &= V_m \omega C \sin (\omega t + 90) \\ &= \frac{V_m}{1/\omega C} \sin (\omega t + 90) \end{aligned}$$

This shows that in a purely capacitive circuit the current through the capacitor leads the voltage across it as shown in Fig. 1.9(b). Here $\frac{1}{\omega C}$ represents reactance of the capacitor. Taking the ratio of the voltage phasor and current phasor we have

$$\begin{aligned} \frac{V \angle 0}{I \angle 90} &= \frac{(V_m / \sqrt{2}) \angle 0}{\frac{V_m}{\sqrt{2}} \cdot \frac{1}{\omega C} \angle 90} = \frac{1}{\omega C} \angle -90^\circ \\ &= \frac{-j}{\omega C} = -jX_C \end{aligned}$$

The average power in a capacitor

$$\begin{aligned} p &= \frac{1}{2\pi} \int_0^{2\pi} V_m I_m \sin \omega t \sin (\omega t + 90^\circ) d\omega t \\ &= \frac{1}{2\pi} \int_0^{2\pi} V_m I_m \sin \omega t \cos \omega t d\omega t \\ &= \frac{1}{2\pi} \int_0^{2\pi} V_m I_m \frac{\sin 2\omega t}{2} d\omega t \\ &= 0 \end{aligned}$$

This again shows that the power consumed in a purely capacitive circuit is zero.

1.6.3 Series R-L Circuit Connected to Sinusoidal Source

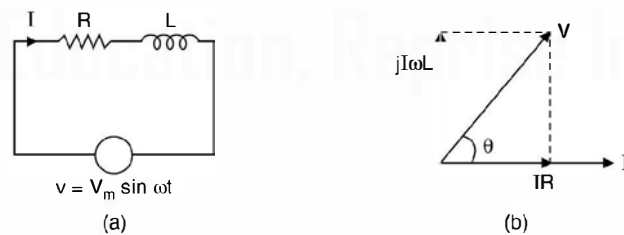

Fig. 1.10

Since current is same through R and L we take it as a reference phasor. The voltage across resistance is in phase with I , hence IR is drawn in phase with I , voltage across inductor is leading the current hence a phasor corresponding to voltage across inductor should lead phasor I by 90° as shown in Fig. 1.10. The sum of the voltage across R and L should equal the supply voltage V .

From the phasor diagram

$$V = IR + jI\omega L$$

or
$$\frac{V}{I} = R + j\omega L$$

From the phasor diagram it is seen that the phase angle between V and I is neither 0° to represent the ratio $\frac{V}{I}$ as resistance nor it is 90° to represent the ratio $\frac{V}{I}$ as reactance

Hence we call this ratio something different from resistance or reactance, we call it impedance. It is to be noted that if we divide the phasor diagram by I we will have another diagram as shown in Fig. 1.10.1.

Impedance even though is a ratio of two phasors it is not a phasor by itself as R and X_L are not function of time and hence while drawing impedance triangle, arrows should not be attached with R and X_L . Angle θ between R and Z is same as the angle between I and V and hence is the phase angle of the impedance and impedance is to be represented by $Z = |Z| \angle \theta$ if it is an inductive circuit and $Z = |Z| \angle -\theta$ if it is a capacitive circuit.

From Fig. 1.10.1 it is seen that

$$R = Z \cos \theta, \quad X_L = Z \sin \theta$$

and
$$Z = \sqrt{R^2 + X_L^2}$$

and
$$\theta = \tan^{-1} \frac{X_L}{R}$$

If V and I correspond to the same circuit and θ is the angle between the two phasors then power in the circuit is given by $P = VI \cos \theta$ where θ is known as power factor angle and $\cos \theta$ is known as power factor of the circuit. The product of V and I is known as apparent power. Hence power factor can be defined as

$$\cos \theta = \frac{P}{VI} = \frac{\text{Real Power}}{\text{Apparent Power}}$$

The component of current along the voltage phasor ($I \cos \theta$) gives real power or actual power whereas the component of current at right angle to the voltage phasor gives what is known as reactive power i.e. the power which does not do any useful work but is present in the system. In fact reactive power is associated with the energy storing elements L and C . The analogy for this can be drawn between force applied to an object. The component of the force along the displacement produces useful work whereas the force applied at right angle to the displacement produces no work.

1.6.4 RC Series Circuit Connected to Sinusoidal Source

Here again since current is same through both the elements, it is taken as the reference phasor. The voltage across R is in phase with I and voltage across C lags the current by 90° as shown in Fig. 1.11(b). The resultant phasor sum of IR and $-jIX_C$ is the supply voltage V .

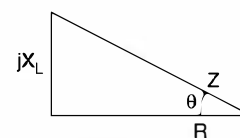

Fig. 1.10.1

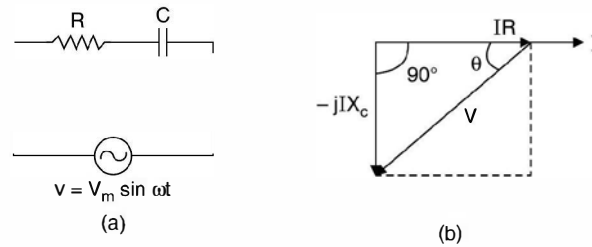

Fig. 1.11

$$V = IR - jIX_C$$

$$\frac{V}{I} = (R - jX_C) = Z$$

Hence

$$Z = R - jX_C = \sqrt{R^2 + X_C^2}$$

$$R = Z \cos \theta, \quad X_C = Z \sin \theta \quad \text{and} \quad \tan \theta = \frac{-X_C}{R}$$

Example 1.2. The impedance of a circuit placed across a 120V, 50 Hz source is $(10 + j20)$. Find current and the power.

Solution: Taking voltage as the reference we have $V = (120 + j0)$

Hence current
$$I = \frac{V}{Z} = \frac{120 + j0}{(10 + j20)}$$

or

$$I = \frac{(120 + j0)(10 - j20)}{(10 + j20)(10 - j20)} = \frac{12 - j24}{5}$$

$$= 2.4 - j4.8 \text{ Amp.}$$

This shows that the current lags the voltage by an angle

$$\theta = \tan^{-1} \frac{-4.8}{2.4} = -63.4^\circ$$

$$I = \sqrt{2.4^2 + 4.8^2} \angle -63.4$$

$$= 5.36 \angle -63.4$$

Power

$$P = VI \cos \theta = 120 \times 5.36 \cos 63.4$$

$$= 288 \text{ watt}$$

The same problem can be solved using polar coordinates as follows :

Taking voltage as reference

$$V = 120 \angle 0$$

Impedance
$$Z = \sqrt{10^2 + 20^2} \tan^{-1} \frac{20}{10}$$

$$= 22.36 \angle 63.4$$

$$I = \frac{V}{Z} = \frac{120 \angle 0}{22.36 \angle 63.4}$$

$$= 5.37 \angle -63.4$$

Power $P = 120 \times 5.37 \cos 63.4 = 288$ watts

Power can also be calculated using the relation

$$P = \text{Real} [VI^*]$$

In Cartesian co-ordinates

$$V = 120 + j0$$

$$I = 2.4 - j4.8$$

Hence $I^* = 2.4 + j4.8$

and
$$P = \text{Re} [(120 + j0)(2.4 + j4.8)]$$

$$= 120 \times 2.4$$

$$= 288 \text{ watts}$$

Example 1.3. A 15 V source is applied to a capacitive circuit that has an impedance of $(10 - j25) \Omega$. Determine the current and the power in the circuit.

Solution: Taking voltage as reference and using j -notation method we have

$$I = \frac{(15 + j0)(10 + j25)}{(10 - j25)(10 + j25)}$$

$$= \frac{150 + j375}{10^2 + 25^2} = \frac{6 + j15}{29}$$

$$= 0.2 + j0.517 \text{ A}$$

This means the current leads the voltage

$$I = 0.55 \tan^{-1} \frac{0.517}{0.2} = 0.55 \angle 68.85$$

which means the current leads the supply voltage by 68.85° which, in this case is also the angle of the impedance $(10 - j25)$.

$$\tan \theta = \frac{-25}{10}, \quad \theta = -68.2^\circ$$

This being capacitive circuit the impedance triangle is as shown here in Fig. E1.3.

The power loss $\text{Re} [VI^*]$

$$= \{15[0.2 - j0.517]\}$$

$$= 3 \text{ watts}$$

This can also be obtained using the formula

$$P = VI \cos \theta$$

$$= 15 \times 0.55 \cos 68.8$$

$$= 3 \text{ watts}$$

Since it is a series circuit and the current through the circuit is 0.55 A and resistance is 10Ω , the power consumed by the circuit is I^2R

$$0.55^2 \times 10 = 3 \text{ watts}$$

The reactive power $Q = VI \sin \theta = 15 \times 0.55 \sin (-68.8)$

$$= -7.7 \text{ Var}$$

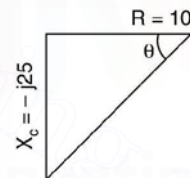

Fig. E1.3

Here reactive power is negative as it is a capacitive circuit. However, for inductive circuits the reactive power is positive.

This is because an inductor absorbs reactive power whereas a capacitor supplies reactive power. This is why, capacitor is also known as reactive power generator.

The current can also be obtained using polar co-ordinates.

$$\begin{aligned} \text{Impedance } z &= \sqrt{10^2 + 25^2} \tan^{-1} \frac{-25}{10} \\ &= 26.95 \angle -68.2^\circ \end{aligned}$$

$$\begin{aligned} \text{Hence current } I &= \frac{15}{26.95 \angle -68.2} \\ &= 0.55 \angle 68.2 \end{aligned}$$

1.6.5 R-L-C Series Circuit Connected to Sinusoidal Source

Refer to Fig. 1.12

Taking current as reference, the phasor diagram for the circuit is shown in Fig. b below. Depending upon which reactance is larger, the current will lead or lag the supply voltage

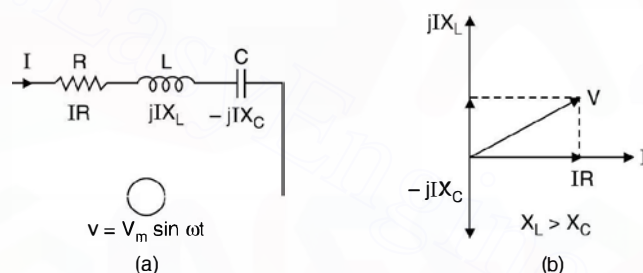

Fig. 1.12

If $X_C > X_L$, current will lead the supply voltage as the net circuit is capacitive otherwise it will lag as the net circuit becomes inductive.

Example 1.4. A 100Ω resistor, $20 \mu F$ capacitor and a $2H$ inductor are connected in series. At what frequency is the phase angle 45° .

Solution: There are two possibilities for angle to be 45° , one when the total circuit is inductive i.e. when $X_L > X_C$ and the other when $X_C > X_L$.

For $\theta = 45^\circ$, $\tan \theta = 1$ for inductance load and when

$$\theta = -45^\circ, \tan \theta = -1$$

$$\text{Now} \quad \tan \theta = \frac{X_L}{R} = 1$$

$$\text{Therefore} \quad X_L = R$$

where X_L is the net inductive reactance

$$\begin{aligned} X_L &= X_{LT} - X_C \\ &= \omega L - \frac{1}{\omega C} \end{aligned}$$

$$100 = 2\pi f_1(2) - \frac{10^6}{2\pi f_1 \times 20}$$

$$= 12.56f_1 - \frac{7.96 \times 10^3}{f_1}$$

or $f_1^2 - 7.96 f_1 - 633 = 0$

or $f_1 = 29.5 \text{ Hz}$

For the second case

$$X_C - X_{LT} = 100$$

$$\frac{10^6}{2\pi f_2 \times 20} - 2\pi f_2(2) = 100$$

or $f_2^2 + 7.96 f_2 - 633 = 0$

or $f_2 = 21.5 \text{ Hz}$

One can check that by using these frequencies the difference of the two reactances in both the cases comes out to be 100 Ω .

Example 1.5. A 120 V, 500 W lamp is used with a series choke on a 230 V, 60 Hz line, what is the inductance of the required choke if the choke has a Q of 2?

Solution: Here we have a 500 W lamp rated at 120 volt whereas the supply voltage is 230 V. Naturally we have to connect some circuit element R , L or C so that the bulb gets 120 V. The resistance of the lamp is given by

$$\frac{V^2}{R} = 500 = \frac{120^2}{R}$$

or $R = \frac{120^2}{500} = 28.8 \Omega$

Here it is suggested to connect a choke which has both resistance as well inductance.

It is also given that Q of the coil is 2

i.e. $\frac{\omega L}{R} = 2$ where R is the resistance of the choke itself.

Now $\omega = 2\pi \times 60 = 376.8 \text{ rad/sec.}$

$$376.8L = 2R$$

or $R = 188.4 L$

Now current in the circuit is

$$120 \times I = 500$$

or $I = \frac{500}{120} = 4.167A$

Hence impedance of the circuit is

$$\frac{230}{4.167} = 55.2 \Omega$$

Also that impedance is

$$(28.8 + 188.4L)^2 + (376.8L)^2 = 55.2^2$$

The solution gives $L = 87 \text{ mH.}$

1.7 PARALLEL R-L CIRCUIT ACROSS SINUSOIDAL SUPPLY

Refer to Fig. 1.13

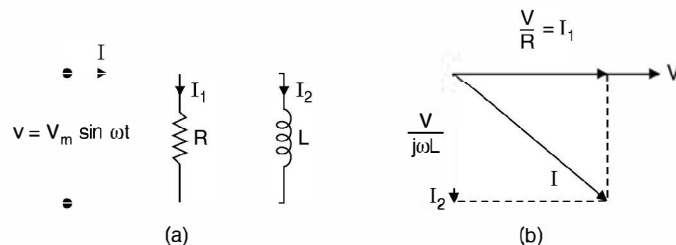

Fig. 1.13

We have taken here V as the reference quantity as it is the voltage which is common to both the elements R and L and not the current. Now current through R will be in phase with the voltage across it whereas current through inductor will lag by 90° the voltage across it. Hence, the phasor diagram in Fig. (b) follows and current I supplied by the source equals the phasor sum of the current I_1 and I_2 .

$$\text{Now} \quad I = I_1 + I_2 = \frac{V}{R} + \frac{V}{j\omega L}$$

Here $\frac{1}{R}$ is the reciprocal of resistance and is termed as conductance whereas $\frac{1}{j\omega L}$ is the reciprocal of the inductive reactance and is known as inductive susceptance.

From the equation above we have

$$\frac{I}{V} = \frac{1}{R} + \frac{1}{j\omega L} \quad \dots(1.3)$$

Now dimensionally $\frac{I}{V}$ is reciprocal of impedance and is known as admittance. The above equation can be rewritten as

$Y = G - jB$ where Y is admittance G the conductance and B the susceptance.

$$Y = \frac{1}{Z}, \quad G = \frac{1}{R} \quad \text{and} \quad B = \frac{1}{\omega L}$$

It is to be noted that whereas for an inductive circuit $z = R + j\omega L$, the admittance is

$$Y = G - jB$$

whereas for a capacitive circuit.

$$Z = R - jX_C \quad \text{the admittance is}$$

$$Y = G + j\omega C = G + jB$$

and hence ωC is the capacitive susceptance. The same observation can also be made as follows :
By definition

$$Y = \frac{1}{Z} = \frac{1}{R + jX} \text{ or inductive circuit}$$

$$= \frac{R - jX}{R^2 + X^2} = \frac{R}{R^2 + X^2} - j \frac{X}{R^2 + X^2}$$

where R and X are connected in series.

The units of admittance is *mho* or siemens and denoted by \mathfrak{U} or S respectively.

The power consumed by the circuit is again $P = VI \cos \theta$ where I is the total current and θ is the angle between V and I .

From equation 1.3 we have

$$\frac{1}{Z} = \frac{1}{R} + \frac{1}{j\omega L}$$

if $Z_1 = R$ and $Z_2 = j\omega L$ we have

$$\frac{1}{Z} = \frac{1}{Z_1} + \frac{1}{Z_2} \quad \dots(1.4)$$

or

$$Z = \frac{Z_1 Z_2}{Z_1 + Z_2}$$

i.e. if there are two impedances Z_1, Z_2 connected in parallel, their equivalent impedance equals the ratio of the product of the two impedance to the sum of the two impedances. Also from equation (1.4)

$$Y = Y_1 + Y_2$$

i.e. if there are two admittances Y_1 and Y_2 connected in parallel, the equivalent admittance is the sum of the two admittances.

1.7.1 Parallel R-C Circuit Across Sinusoidal Source

Refer to Fig. 1.14

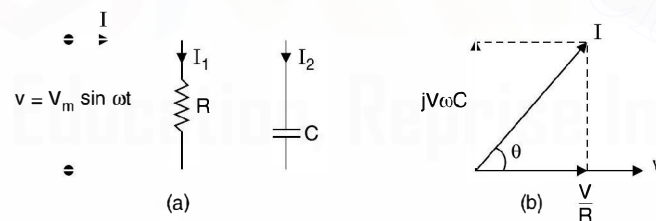

Fig. 1.14

From the phasor diagram

$$I = \frac{V}{R} + jV\omega C$$

or

$$\frac{I}{V} = \frac{1}{R} + j\omega C$$

$$Y = G + jB$$

Example. 1.6. The impedance of a parallel RC circuit is $(10 - j30) \Omega$ at 1 MHz. Determine the values of the components.

Solution: The admittance of the circuit is

$$Y = \frac{1}{Z} = \frac{1(10 + j30)}{(10 - j30)(10 + j30)} = \frac{10 + j30}{1000} = \frac{1}{100} + j \frac{3}{100}$$

i.e. $G = \frac{1}{R} = \frac{1}{100}$ and $B = \omega C$

i.e. $R = 100 \Omega$ and $B = \frac{3}{100} = 10^6 C \cdot 2\pi$

or $C = \frac{3}{100} \times \frac{1}{2\pi \times 10^6} = \frac{3}{200\pi} \mu F = 4.7 \text{ nF}$.

Example 1.7. A 4700Ω resistor and a $2 \mu F$ capacitor are connected in parallel across a 240 V 60 Hz source. Determine the circuit impedance and the line current.

Solution:

Current $I_R = \frac{240}{4700} = 0.051 \text{ A}$

$$I_C = j\omega CV$$

$$= j2\pi \times 60 \times 2 \times 10^{-6} \times 240$$

$$= j0.1808$$

Total current $= I_R + I_C = 0.051 + j0.1808$

$$= \frac{V}{R} + jV/1/\omega C$$

Therefore, impedance of the circuit is $\frac{V}{I}$

$$= \frac{240}{0.188 \angle 74.3}$$

$$= 1276 \angle -74.3 \Omega$$

1.7.2 Series Parallel Circuits of R, L and C

Refer to Fig. 1.15

The current I_C will of course lead the reference voltage V by 90° . Regarding RL series circuit, let the impedance angle be θ . Since it is an inductive circuit, current I_L will lag the voltage across it (supply voltage here) by angle θ . Hence total line current I is phasor sum of I_L and I_C as shown in Fig. 1.15(b).

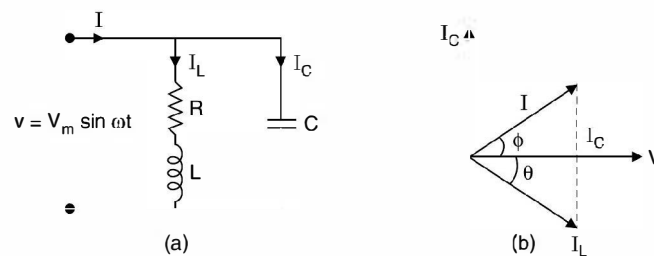

Fig. 1.15

Example 1.8: Determine the line current and the total impedance and admittance of the circuit shown in Fig. E 1.8.

Solution:

$$Z_1 = 25 + j50 = 55.9 \angle 63.4$$

$$Z_2 = 40 \angle -90$$

$$\begin{aligned} \text{Hence } Z_{eq} &= \frac{Z_1 Z_2}{Z_1 + Z_2} = \frac{55.9 \angle 63.4 \cdot 40 \angle -90}{25 + j50 - j40} \\ &= \frac{2236 \angle -26.6}{26.9 \angle 21.8} \\ &= 83.12 \angle -48.4^\circ \end{aligned}$$

$$\begin{aligned} \text{Admittance } Y &= \frac{1}{Z} = \frac{1}{83.12 \angle -48.4} \\ &= 1.2 \times 10^{-2} \angle 48.4^\circ \end{aligned}$$

$$\begin{aligned} \text{Total current } I &= VY = 100 \times 1.2 \times 10^{-2} \angle 48.4^\circ \\ &= 1.2 \angle 48.4^\circ \text{ A } \quad \text{Ans.} \end{aligned}$$

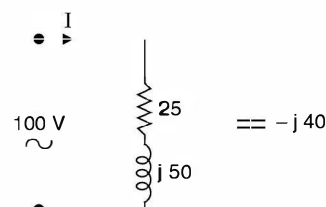

Fig. E 1.8

1.8 RESONANCE

Whenever the natural frequency of oscillation of a system (could be electrical, mechanical or a civil structure or a hydraulic) coincides with the frequency of the driving force (a voltage source in an electric circuit or a wind force in a civil structure etc.), the two system resonate with respect to each other and the system has maximum response to a fixed magnitude of driving force. This phenomenon is known as resonance. This phenomenon may be useful under certain conditions and sometimes it may prove to be disastrous for the system.

There are many engineering applications of resonance. In a refrigerator, the reciprocating compressor is mounted on a support designed to minimize the vibrations transmitted to the cabinet. A suspension bridge in Washington showed tendencies to oscillate up and down during construction and only a few months after construction, it began to build up oscillations under a moderate wind and within an hour the multi-billion dollar bridge was reduced to pieces. This is a typical example of designing a bridge ignoring the possibility of phenomenon of resonance on the bridges.

In case of a series compensated power system if the difference between the normal power frequency and the natural frequencies of oscillation of the system after compensation coincides with one of the natural torsional frequencies of the machine's shaft system (Turbine, or combination of turbine and generator), torsional oscillation may be excited which may build up sufficiently to break the shaft of these machines. This is known as subsynchronous resonance as the resonance occurs at a frequency less than the normal supply frequency.

A power transformer is normally operated at the knee-point of its B-H curve due to economic reasons. If somehow the system voltage increases due to Ferranti effect or due to rejection of load, the transformer operates along the saturation region of the B-H curve where the inductance offered by the winding decreases and keeps on changing depending upon the dynamic behaviour of increase of system voltage. Saturation of transformers subjected to over

voltages can produce high currents rich in harmonics and in the presence of sufficient capacitance there is risk of phenomenon of resonance taking place which may result in further increase in system voltages which may prove disastrous for the system insulation. This is known as Ferro-resonance as it is due to the non-linear behaviour of the iron core of the transformer. In such a situation it may be necessary to disconnect shunt capacitors very quickly to reduce the chances of occurrences of Ferro-resonance.

In an electric circuit with inductance and capacitor in series, there is always a frequency at which the two reactances just cancel resulting in the minimum impedance (resistive circuit) characteristic of series resonance. In electronic circuits many a times resonance condition is desired for maximum response for a given magnitude of excitation.

In general there are two types of resonance in the electric circuits :

- (a) Series resonance,
- (b) Parallel resonance.

We now study basic features and characteristic of these phenomena.

1.9 SERIES RESONANCE

Consider a series *RLC* circuit connected to a variable frequency voltage source as shown in Fig. 1.16.

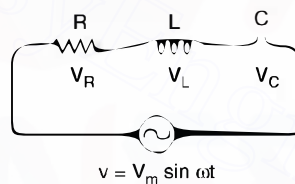

Fig. 1.16 Series RLC circuit with a.c. source.

The impedance of the circuit at any frequency ω is given as

$$\begin{aligned} Z &= R + j\omega L - \frac{j}{\omega C} \\ &= R + j \left(\omega L - \frac{1}{\omega C} \right) \end{aligned} \quad \dots(1.5)$$

Since resistance is independent of frequency the circuit will have minimum impedance at some frequency.

$$\text{When} \quad Z = R \quad \dots(1.6)$$

$$\text{or when} \quad \omega_0 L - \frac{1}{\omega_0 C} = 0$$

$$\begin{aligned} \text{or} \quad \omega_0 &= \frac{1}{\sqrt{LC}} \\ f_0 &= \frac{1}{2\pi\sqrt{LC}} \end{aligned} \quad \dots(1.7)$$

Here f_0 is the frequency of resonance i.e. if a circuit has fixed values of R , L and C , resonance will take place if the supply frequency

$f_0 = \frac{1}{2\pi\sqrt{LC}}$ when the impedance of the circuit is purely resistive i.e. the power factor of the circuit is unity, the supply voltage and current are in phase. However, it is to be noted that the phase relations between the voltage and current in the individual elements R , L and C are not same. The current in the inductor lags its voltage by 90° and in the capacitor it leads its voltage by 90° .

The variation of impedance of the three elements as a function of frequency is shown in Fig. 1.17.

Since R is independent of frequency it is shown by a horizontal line $Z = R$.

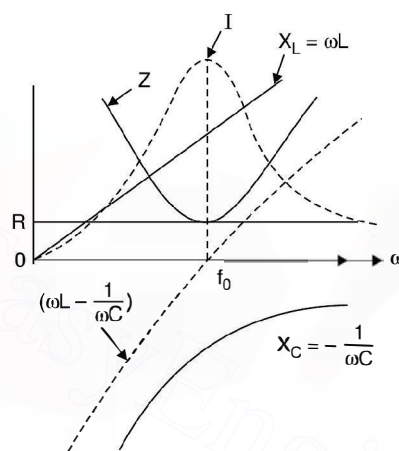

Fig. 1.17 $ZV_s \omega$ for RLC series circuit.

Also $X_L = \omega L$ the inductive reactance is a straight line passing through the origin and inductive reactance is taken as +ve, whereas $X_C = \frac{1}{\omega C}$ the capacitive reactance as a function of ω is a rectangular hyperbola and the reactance is taken as -ve. The net impedance is shown a positive quantity. The resonance frequency is f_0 where $\left(\omega L - \frac{1}{\omega C}\right)$ is zero and at this frequency the impedance curve has minimum value equal to R . The variation of current is also shown in Fig. 1.17 as a function of frequency and is maximum at f_0 whereas on either side the current decreases. It is to be noted that at $\omega = 0$, the current in the RLC series circuit is zero as the capacitor reactance is infinite and, therefore, the graph starts from origin whereas it is again zero at $\omega = \infty$ and hence the graph should not be passing through zero rather it should have some finite value as indicated in the diagram.

Again, it can be seen that the series circuit is capacitive for all frequency $\omega < \omega_0$ and at $\omega = \omega_0$ the circuit is resistive. Fig. 1.18 shows the current response of the RLC series circuit for certain voltage V when one of the three parameters is changed at a time.

It is seen that the current response curve must always start from origin and the frequency of resonance can be varied by varying either L , or C or both. The steepness of the response curve can be varied by varying the resistance of the circuit.

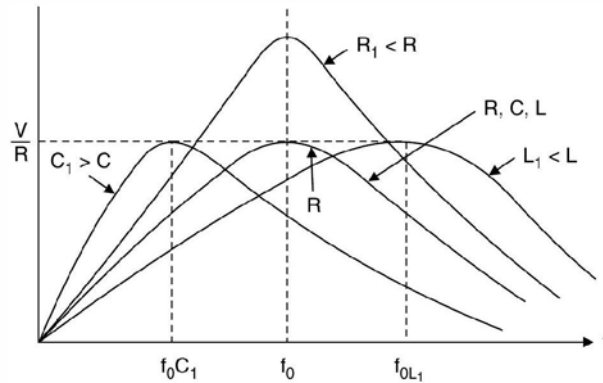

Fig. 1.18 Current response for RLC series circuit.

There are various applications of a series resonant circuit where the frequency is fixed and either L or C is varied to obtain the condition of resonance. A typical example is that of tuning a radio receiver to a particular desired station that is operating at a fixed frequency. Here a circuit or L and C is adjusted to resonance at the operating frequency of the desired station. The capacitor C (parallel plate) is variable in most portable radio receivers and the inductance of the coil is usually varied in tuning of an automobile radio receiver.

Example 1.9. For the Fig. E 1.9 shown determine the maximum current, the frequency at which it occurs and the resulting voltage across the inductance and capacitance.

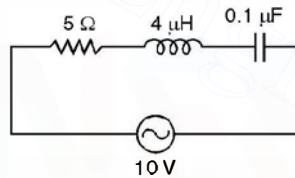

Fig. E1.9

Solution: The frequency at which the current is maximum is

$$\omega_0 = \frac{1}{\sqrt{4 \times 10^{-3} \times 0.1 \times 10^{-6}}}$$

$$= 5 \times 10^4 \text{ rad/sec.}$$

The current at resonance is $\frac{V}{R} = \frac{10}{5} = 2\text{A}$

The voltage across the inductance

$$= \omega_0 LI = 5 \times 10^4 \times 4 \times 10^{-3} \times 2$$

$$= 400 \text{ V}$$

and voltage magnitude across the capacitor is

$$= \frac{1}{\omega_0 C} = \frac{2}{5 \times 10^4 \times 0.1 \times 10^{-6}}$$

$$= 400 \text{ V}$$

It is seen that the voltage across L or C under resonance is greater than the voltage across all the three elements i.e. the supply voltage.

Fig. E 1.9 shows phasor diagram of the RLC series circuit corresponding to $\omega < \omega_0$, $\omega = \omega_0$ and $\omega > \omega_0$. We have taken current as the reference phasor as it is a series circuit and current is same through all the elements.

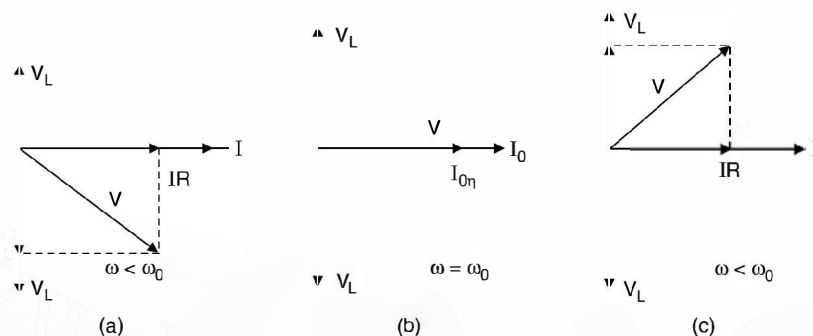

Fig. E1.9 Phasor diagram of RLC series circuit (a) $\omega < \omega_0$ (b) $\omega = \omega_0$ (c) $\omega > \omega_0$.

In Fig. 1.9(a) since $\omega < \omega_0$, the circuit is predominantly capacitive hence the net supply voltage lags behind the circuit current. However the voltage across the inductor leads the current by 90° , the voltage across the resistor is in phase with the circuit current whereas voltage across the capacitor lags behind the current by 90° . The voltage across inductor and capacitor are 180° out of phase with reference to each other. Since the circuit at this frequency is capacitive the net voltage lags behind the circuit current by some angle.

In Fig. E 1.9(b) since $\omega = \omega_0$ the circuit is resistive as the voltage drop across inductance exactly cancels the voltage across the capacitance as these are equal in magnitude but opposite in phase relation. It is to be seen that under this condition voltage across L or C individually may far exceed the supply voltage.

Next we find expression for voltage drops across individual elements under resonance condition.

Under resonance

$$I_0 = \frac{V}{R} \quad \dots(1.8)$$

Therefore,

$$V_R = I_0 R = \frac{V}{R} \cdot R = V \text{ the supply voltage} \quad \dots(1.9)$$

$$\begin{aligned} V_L = I_0 \omega L &= \frac{V}{R} \omega_0 L = V \cdot \frac{\omega_0 L}{R} \\ &= VQ \end{aligned} \quad \dots(1.10)$$

where Q is known as the quality factor of the series network. Usually $Q \gg 1$, hence it is also known as voltage gain, as the voltage across the inductor is much greater than the supply voltage.

Also
$$V_C = \frac{I_0}{\omega_0 C} = V \cdot \frac{1}{\omega_0 CR}$$

$$= VQ \quad \dots(1.11)$$

Hence
$$V_L = V_C \gg V$$

Therefore, extreme care must be taken when working on series circuits that may become resonant when connected to power line sources.

Example 1.10. In an RLC series circuit shown in Fig. E1.10 determine (i) the necessary value of capacitor (ii) the supply voltage to produce a voltage of 5 volts across the capacitance if resonance frequency is 5 KHz (iii) If the capacitance is made 1/2 of at (i), determine the frequency of resonance, the Q of the new circuit.

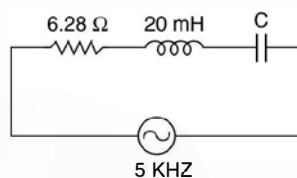

Fig. E1.10

Solution:

$$5000 = \frac{1}{2\pi\sqrt{20 \times 10^{-3} \times C \times 10^{-6}}}$$

$$C = 0.0507 \mu F$$

$$V_C = 5 = V \cdot \frac{1}{2\pi \times 5 \times 10^3 \times 0.0507 \times 10^{-6} \times 6.28}$$

or
$$V = 0.05 \text{ volt}$$

(iii) If the capacitance is halved, the frequency of resonance would be $\sqrt{2} f_0$

$$= \sqrt{2} \times 5000 = 7071 \text{ Hz}$$

and Q of the coil
$$= \frac{2\pi \times 7071 \times 20 \times 10^{-3}}{6.28}$$

$$= 141.4 \text{ Ans.}$$

1.9.1 Quality Factor Q

In a practical circuit R is essentially resistance of the coil since practical capacitors have very low loss in comparison to practical inductor. Hence Q is a measure of the energy storage property (LI^2) in relation to the energy dissipation property (I^2R) of a coil or a circuit. The Q is, therefore, defined as

$$Q = 2\pi \cdot \frac{\text{maximum energy stored}}{\text{energy dissipated per cycle}} \quad \dots(1.12)$$

In electric circuit energy is stored in the form of electromagnetic field in the inductance where as in electrostatic form of energy across a capacitance. It can be proved that at any instant at a certain frequency the sum of energy stored by the inductor and the capacitor is

constant. At the extreme situation when the current through the inductor is maximum, the voltage across the capacitor is zero hence the total energy is

$$\frac{1}{2} L(\sqrt{2}I)^2 = LI^2 \quad \dots(1.13)$$

where $\sqrt{2}I$ is the instantaneous maximum value of the current. At this since V_C is zero, therefore maximum energy stored is LI^2 . The power consumed per cycle is the energy per sec divided by f_0 under resonance condition. Therefore $P_R = \frac{I^2 R}{f_0}$

Hence
$$Q = \frac{2\pi LI^2 f_0}{I^2 R} = \frac{\omega_0 L}{R} \quad (1.14)$$

Q can also be looked as the ratio of

$$\begin{aligned} & \frac{\text{Time rate of change of energy stored}}{\text{Time rate of change of energy dissipated}} \\ &= \frac{\text{Reactive power absorbed by the inductor}}{\text{Active power consumed by the resistor}} \quad \dots(1.15) \end{aligned}$$

The great advantage of this definition of Q is that it is also applicable to more complicated lumped circuits, to distributed circuits such as transmission lines and to non-electrical circuits.

Q is also a measure of the frequency selectivity of the circuit. A circuit with high Q will have a very sharp current response curve as compared to one which has a low value of Q . To understand this let us consider Fig. 1.19. Here we find that the current response is maximum at f_0 and on either side of f_0 , the current decreases sharply.

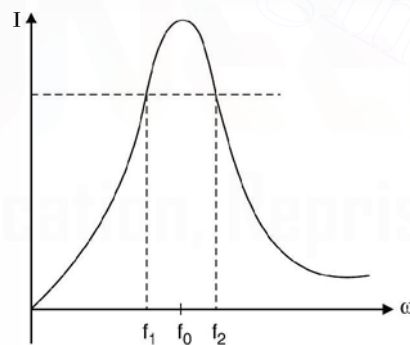

Fig. 1.19 Frequency selectivity.

In order to obtain quantitative analysis of this reduction in current, we specify two frequencies f_1 and f_2 at which the magnitude $(X_L - X_C)$ is equal to R .

Since at f_1 the circuit is capacitive X_C is greater than X_L , therefore, at f_1 ,

$$X_C - X_L = R \quad \dots(1.16)$$

and at f_2

$$X_L - X_C = R \quad \dots(1.17)$$

The corresponding impedances are :

$$Z_1 = \sqrt{R^2 + R^2} \angle \tan^{-1} \frac{-R}{R} = \sqrt{2} R \angle -45^\circ \quad \dots(1.18)$$

and
$$Z_2 = \sqrt{R^2 + R^2} \angle \tan^{-1} \frac{-R}{R} = \sqrt{2} R \angle 45^\circ \quad \dots(1.19)$$

The current at these two frequencies are :

$$I_1 = \frac{V \angle 45^\circ}{\sqrt{2} R} \quad \dots(1.20)$$

and
$$I_2 = \frac{V \angle -45^\circ}{\sqrt{2} R} \quad \dots(1.21)$$

Since $\frac{V}{R} = I_0$ the current at resonance at f_0 .

$$I_1 = 0.707 I_0 \angle 45^\circ \quad \dots(1.22)$$

and
$$I_2 = 0.707 I_0 \angle -45^\circ \quad \dots(1.23)$$

Frequencies f_1 and f_2 are known as half-power frequencies as at these frequencies the power dissipated by the circuit is half of that dissipated at f_0 .

The band width of a resonant circuit is defined as the frequency range between the 70.7% current points.

i.e.
$$BW = f_2 - f_1 \quad \dots(1.24)$$

At f_1
$$X_C - X_L = R \quad \dots(1.25)$$

$$\frac{1}{2\pi f_1 C} - 2\pi f_1 L = R \quad \dots(1.26)$$

and at f_2

$$X_L - X_C = R \quad \dots(1.27)$$

$$2\pi f_2 L - \frac{1}{2\pi f_2 C} = R \quad \dots(1.28)$$

On subtracting (1.28) from (1.26) we have

$$\left(\frac{1}{\omega_1} + \frac{1}{\omega_2} \right) \frac{1}{C} - (\omega_1 + \omega_2)L = 0$$

or
$$\frac{\omega_2 + \omega_1}{\omega_1 \omega_2} = LC (\omega_1 + \omega_2)$$

or
$$\frac{1}{\omega_1 \omega_2} = LC = \frac{1}{\omega_0^2}$$

or
$$\omega_0 = \sqrt{\omega_1 \omega_2} \quad \dots(1.29)$$

This means the resonance frequency is the geometric mean of the half-power frequencies.

Now on addition of (1.26) and (1.28) we have

$$\frac{1}{\omega_1 C} - \frac{1}{\omega_2 C} + \omega_2 L - \omega_1 L = 2R$$

$$\text{or } \frac{\omega_2 - \omega_1}{\omega_1 \omega_2 C} + (\omega_2 - \omega_1)L = 2R$$

$$\text{or } (\omega_2 - \omega_1) \left(\frac{1}{\omega_0^2 C} + L \right) = 2R$$

$$\text{or } (\omega_2 - \omega_1) \left(\frac{2}{\omega_0^2 C} \right) = 2R$$

$$\text{or } (\omega_2 - \omega_1) = \omega_0^2 CR$$

$$\frac{\omega_2 - \omega_1}{\omega_0} = \omega_0 CR = \frac{1}{Q}$$

$$f_2 - f_1 = \frac{f_0}{Q} \quad \dots(1.30)$$

Bandwidth is thus given by the ratio of the frequency of resonance to the quality factor and selectivity is defined as the ratio of resonant frequency to the bandwidth $f_0/(f_2 - f_1)$. This, therefore, shows that the larger the value of Q the smaller is $(f_2 - f_1)$ and hence sharper is the current response.

Example 1.11. For the circuit shown determine the value of inductance for resonance if $Q = 50$ and $f_0 = 175$ KHZ. Also find the circuit current the voltage across the capacitor and the bandwidth of the circuit.

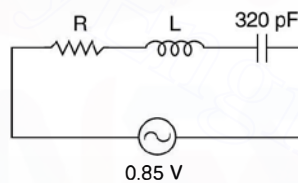

Fig. E1.11

Solution:

$$f_0 = \frac{1}{2\pi\sqrt{LC}}$$

$$175 \times 10^3 = \frac{1}{2\pi\sqrt{320 \times 10^{-12} L}}$$

$$\text{or } L = 2.58 \text{ mH}$$

The reactance of the coil at resonance is

$$2\pi \times 175 \times 10^3 \times 2.58 \times 10^{-3} = 2840 \Omega$$

Since $Q = \frac{\omega_0 L}{R}$

$$\text{or } R = \frac{\omega_0 L}{Q} = \frac{2840}{50} = 56.8 \Omega$$

The impedance of the circuit at resonance is

$$Z = R = 56.8 \Omega$$

Therefore, current $I_0 = \frac{0.85}{56.8} = 14.96 \text{ mA}$

$$\begin{aligned} \text{The voltage across the capacitor} &= QV \\ &= 50 \times 0.85 = 42.5 \text{ volt} \end{aligned}$$

$$\text{The bandwidth of the circuit is } \frac{f_0}{Q} = \frac{175 \times 10^3}{50}$$

$$\begin{aligned} \frac{f_0}{Q} &= 3.5 \times 10^3 \text{ Hz} \\ &= 3.5 \text{ KHz.} \end{aligned}$$

Example 1.12. For the circuit shown, determine the impedance magnitude at resonance, at 1 KHz below resonance and, at 1 KHz above resonance.

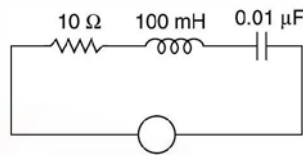

Fig. E1.12

Solution:

$$\begin{aligned} f_0 &= \frac{1}{2\pi\sqrt{100 \times 10^{-3} \times 0.01 \times 10^{-6}}} \\ &= 5.03 \text{ KHz} \end{aligned}$$

$$\text{Frequency } f_1 = 5.03 - 1 = 4.03 \text{ KHz}$$

$$\text{and } f_2 = 5.03 + 1 = 6.03 \text{ KHz}$$

Note these f_1 and f_2 are not necessarily half power frequencies and hence Z_1 need not necessarily equal Z_2 .

$$Z_1 = \sqrt{10^2 + (2.53 - 3.95) \times 10^6}$$

Since 10 is negligibly small as compared to X_L and X_C which are in $K\Omega$, therefore,

$$Z_1 = -j1.42 \text{ K}\Omega$$

$$Z_2 = j3.79 - j2.64 = j1.15 \text{ K}\Omega \quad \text{Ans.}$$

Before we move to parallel resonance, let us summarize the characteristics of series resonance circuit.

1. At resonance power factor of the circuit is unity.
2. Therefore, supply voltage and current are in phase.
3. The reactive component of the input impedance is zero and hence the circuit is resistive and hence current drawn by the circuit is maximum.
4. The frequency of resonance is given by

$$f_0 = \frac{1}{2\pi\sqrt{LC}}$$

5. Even there is voltage across the individual reactive element but across both the elements the net voltage is zero as the two voltages are equal in magnitude but 180° out of phase. The voltage across each reactive element is QV where Q is the quality factor of the element and V is the supply voltage.

6. The quality factor

$$Q = \frac{\omega_0 L}{R} = \frac{1}{\omega_0 CR} \quad \dots(1.31)$$

7. For $\omega < \omega_0$ the circuit is capacitive

$\omega = \omega_0$ the circuit is resistive

$\omega > \omega_0$ circuit is inductive.

8. The band width $f_2 - f_1 = \frac{f_0}{Q}$

and
$$f_0 = \sqrt{f_1 f_2}$$

Example 1.13. For the circuit shown in Fig. E1.13 $R_1 = 0.5 \Omega$, $R_2 = 1.5 \Omega$, $R_3 = 0.5 \Omega$, $C_1 = 6 \mu F$ and $C_2 = 12 \mu F$, $L_1 = 25 \text{ mH}$ and $L_2 = 15 \text{ mH}$. Determine (i) the frequency of resonance (ii) Q of the circuit (iii) Q of coil 1 and coil 2 individually

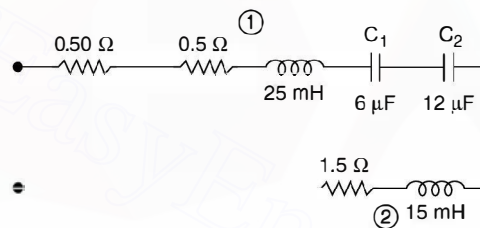

Fig. E1.13

Solution:

Total inductance of the circuit $25 + 15 = 40 \text{ mH}$

Total capacitance of the circuit $\frac{6 \times 12}{18} = 4 \mu F$

$$\begin{aligned} \text{The frequency of resonance} &= \frac{1}{2\pi\sqrt{40 \times 10^{-3} \times 4 \times 10^{-6}}} \\ &= \frac{10^4}{8\pi} \text{ Hz or } \omega_0 = 2.5 \times 10^3 \text{ rad/sec} \end{aligned}$$

$$\begin{aligned} Q \text{ of the circuit} &= \frac{\omega_0 L_{eq}}{R_{eq}} = \frac{2.5 \times 10^3 \times 40 \times 10^{-3}}{2.5} \\ &= 40 \text{ Ans.} \end{aligned}$$

$$Q \text{ of coil 1 } \frac{\omega_0 L_1}{R_1} = \frac{2.5 \times 10^3 \times 25 \times 10^{-3}}{0.5} = 125$$

$$\begin{aligned} Q \text{ of coil 2 } \frac{\omega_0 L_2}{R_2} &= \frac{2.5 \times 10^3 \times 15 \times 10^{-3}}{1.5} = \frac{2.5 \times 15}{1.5} \\ &= 25 \text{ Ans.} \end{aligned}$$

$$\begin{aligned}\text{Bandwidth of the circuit} &= \frac{f_0}{Q} \\ &= \frac{10^4}{8\pi \times 40} = 9.95 \text{ Hz.}\end{aligned}$$

Example 1.14. A coil having a 5 ohm resistor is connected in series with a $50 \mu\text{F}$ capacitor. The circuit resonates at 100 Hz (a) Determine the inductance of the coil. (b) If the circuit is connected across a 200 V 100 Hz a.c. source, determine the power delivered to the coil (c) the voltage across the capacitor and the coil (d) the bandwidth of the circuit.

Solution: At resonance $\omega_0 = \frac{1}{\sqrt{LC}}$

$$2\pi \times 100 = \frac{1}{\sqrt{50 \times 10^{-6} L}}$$

or $L = \frac{25}{500} = 50 \text{ mH}$

The current at resonance $= \frac{200}{5} = 40 \text{ A}$

Therefore, power dissipated $40^2 \times 5 = 8000 \text{ watts.}$

$$= 8 \text{ kW.}$$

Voltage across capacitor

$$= IX_c$$

$$= \frac{40}{50 \times 10^{-6} \times 100 \times 6.28}$$

$$= \frac{40 \times 10^6}{5 \times 10^3 \times 6.28} = \frac{8000}{6.28}$$

The impedance of the coil $R + j\omega_0 L$

$$= 5 + j628 \times 50 \times 10^{-3}$$

$$= 5 + j31.40$$

The voltage

$$V_L = 40(5 + j31.4)$$

$$\approx 1256 \text{ volts Ans.}$$

The Q_0 of the coil

$$= \frac{31.4}{5} \approx 6.3$$

The bandwidth

$$= \frac{f_0}{Q_0} = \frac{100}{6.3} \approx 16 \text{ Hz}$$

1.10 PARALLEL RESONANCE

Consider Fig. 1.20 where L and C are connected in parallel. In series with these elements, resistances shown are their own resistances. Coil will have its own resistance and the capacitor may have some loss component. In general there could be external resistance in series with these elements.

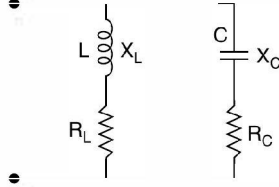

Fig. 1.20 Parallel resonance.

The input admittance is the sum of the admittances of the two branches.

$$\begin{aligned}
 Y_{e\theta} &= \left(\frac{R_c}{R_c^2 + X_c^2} + j \frac{X_c}{R_c^2 + X_c^2} \right) + \left(\frac{R_L}{R_L^2 + X_L^2} - j \frac{X_L}{R_L^2 + X_L^2} \right) \\
 &= \left(\frac{R_c}{R_c^2 + X_c^2} + \frac{R_L}{R_L^2 + X_L^2} \right) + j \left(\frac{X_c}{R_c^2 + X_c^2} - \frac{X_L}{R_L^2 + X_L^2} \right)
 \end{aligned}$$

Now at resonance the imaginary part (susceptance) of admittance is zero.

Therefore,

$$\frac{X_c}{R_c^2 + X_c^2} = \frac{X_L}{R_L^2 + X_L^2} \quad \dots(1.32)$$

or

$$X_{c_0} R_L^2 + X_{c_0} X_{L_0}^2 = X_{L_0} R_c^2 + X_{L_0} X_{c_0}^2$$

$$\frac{1}{2\pi f_0 C} R_L^2 + \frac{1}{2\pi f_0 C} \cdot (2\pi f_0 L)^2 = 2\pi f_0 L R_c^2 + \frac{2\pi f_0 L}{(2\pi f_0 C)^2}$$

Multiplying by $2\pi f_0 C$ we have

$$R_L^2 + 4\pi^2 f_0^2 L^2 = 4\pi^2 f_0^2 R_c^2 LC + \frac{L}{C}$$

or

$$4\pi^2 f_0^2 LC \left(R_c^2 - \frac{L}{C} \right) = R_L^2 - \frac{L}{C}$$

or

$$4\pi^2 f_0^2 = \frac{1}{LC} \cdot \frac{R_L^2 - L/C}{R_c^2 - L/C}$$

or

$$f_0 = \frac{1}{2\pi\sqrt{LC}} \cdot \sqrt{\frac{R_L^2 - L/C}{R_c^2 - L/C}} \quad \dots(1.33)$$

This is the frequency of resonance of the general parallel RLC circuit.

The equivalent input admittance is real and is given as

$$Y_{e\theta_0} = G_0 = \frac{R_c}{R_c^2 + X_c^2} + \frac{R_L}{R_L^2 + X_L^2} \quad \dots(1.34)$$

Here if R_c is the equivalent series resistance of the capacitance, it can be ignored as it usually is small in magnitude, the equivalent circuit then is given in Fig. 1.21.

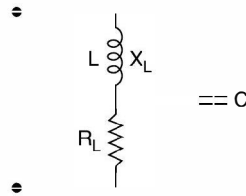

Fig. 1.21 Parallel LC circuit with $R_c = 0$.

The resonance frequency for the circuit is given by the following expression when $R_c = 0$ in the general circuit expression.

$$\begin{aligned} f_0 &= \frac{1}{2\pi\sqrt{LC}} \cdot \sqrt{\frac{R_L^2 - L/C}{-L/C}} \\ &= \frac{1}{2\pi\sqrt{LC}} \cdot \sqrt{1 - R_L^2 \frac{C}{L}} \end{aligned} \quad \dots(1.35)$$

The general expression for Y_{in} in this case is obtained by putting $R_c = 0$ in the expression for Y_{eq} and variation of Z_{in} and I_{input} vs ω are drawn in Fig. 1.22 (a) and (b).

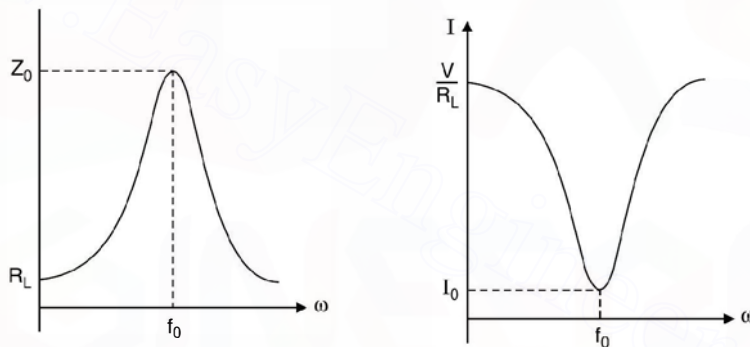

Fig. 1.22 (a) Z Vs f (b) I Vs f for parallel resonance.

The shape of curve for current and Y_{in} will be identical as $I = Y_{in} V$.

It is seen that at resonance the circuit has maximum impedance and hence the current is minimum. At this frequency since the susceptance of the circuit is zero, the power factor of the circuit is unity.

At frequency $f < f_0$ since the capacitance acts as an open circuit the net circuit is inductive and at higher frequencies $f > f_0$ the inductor acts as an open circuit the net circuit is capacitive.

If we now consider that in the general circuit if R_L is also zero besides R_c being zero, we have the equivalent circuit (Fig. 1.23).

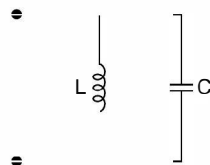

Fig. 1.23 Parallel LC circuit.

For this the frequency of resonance is

$$f_0 = \frac{1}{2\pi\sqrt{LC}} \quad \dots(1.36)$$

and it can be seen that at the frequency the input impedance is

$$\frac{j X_L(-j X_c)}{j X_L - j X_c} = \frac{j X_L(-j X_c)}{0} = \infty$$

and hence theoretically the current drawn from the source is zero. This means there will be current in each parallel path but the net current from the supply is zero i.e. there will be exchange of energy between the inductance and the capacitance of the circuit. Actually because of the small winding resistance of the coil some power is lost so the reactive currents are not exactly identical and there is a small current from the source to take into account this loss.

If we assume that

$$R_L = R_c = \sqrt{\frac{L}{C}} = \sqrt{\frac{\omega L}{\omega C}} = \sqrt{X_L X_c}$$

Therefore,
$$Y_{in} = \frac{R_c}{X_L X_c + X_c^2} + \frac{R_L}{X_L X_c + X_L^2} + j \left(\frac{X_c}{X_L X_c + X_c^2} - \frac{X_L}{X_L X_c + X_L^2} \right)$$

The imaginary part

$$= \frac{X_L X_c^2 + X_c X_L^2 - X_L^2 X_c - X_L X_c^2}{(X_L X_c + X_c^2)(X_c X_L + X_L^2)} = 0$$

Therefore, Y_{in} is resistive at all frequencies that means resonance will occur at all frequencies.

Consider Fig. 1.21. The impedance of the parallel circuit is

$$Z_T = \frac{(R + jX_L) \cdot (-jX_c)}{R + jX_L - jX_c} \quad \dots(1.37)$$

Let

$$X_L = X_c$$

Therefore,

$$Z_T = \frac{(X_L - jR)X_c}{R} \quad \dots(1.38)$$

Let

$$\frac{X_L}{R} = Q \text{ the quality factor of the coil,}$$

$$Z_T = (Q - j1)X_c$$

Usually $Q \gg 1$, therefore,

$$\dots(1.39)$$

At resonance

$$Z_T = Q X_{C0} \quad \dots(1.40)$$

Since this impedance is effectively a pure resistance, for the high Q -circuit, resonance occurs when $X_{L0} = X_{C0}$.

and

$$f_0 = \frac{1}{2\pi\sqrt{LC}}$$

These relations hold good only when $Q \gg 1$ (should be greater than 5). Similarly bandwidth of the circuit is

$$BW = \frac{f_0}{Q}$$

Example 1.15. For the circuit shown in Fig. E 1.15 determine the current through the parallel branches and, the supply current.

(b) If the frequency is made $f_0/2$ and $2f_0$ determine the currents from the source under these conditions.

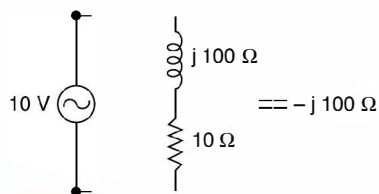

Fig. E1.15 Value at resonance.

Solution: (a) $Z_0 = QX_{C0} = \frac{100}{10} \times 100 = 1000 \Omega$

The current $I_0 = \frac{V}{Z_0} = \frac{10}{1000} = 10 \text{ mA}$

The current through the capacitor branch

$$I_C = \frac{10}{-j100} = j100 \text{ mA}$$

$$I_L = \frac{10}{j100} = -j100 \text{ mA}$$

The current through capacitor and inductor are QI_0 . These large currents in L and C are called oscillating currents because they are confined within the L and C of the parallel resonant circuit. The supply current is 10 mA which supplies the losses of the parallel resonance circuit. The input power from the source is $10 \times 10 = 100 \text{ mW}$.

The I^2R loss in the 10Ω resistor is

$$(0.01)^2 \times 10 = 100 \text{ mW}$$

If however, the frequency is reduced to $f_0/2$ the inductive reactance become 50Ω and capacitor 200Ω .

The net impedance $= \frac{(10 + j50)(-j200)}{10 + j50 - j200}$
 $= 68.8 \angle 75^\circ$

The current $I = \frac{10 \angle -75^\circ}{68.8}$
 $= 0.145 \angle -75^\circ$

If the frequency is doubled

$$X_L = j200 \quad \text{and} \quad X_C = -j50$$

$$Z_T = \frac{(10 + j200)(-j50)}{10 + j200 - j50}$$

$$= 66.4 \angle -89^\circ$$

The current
$$I = \frac{10 \angle 89^\circ}{66.4}$$

$$= 0.151 \angle 89^\circ$$

This shows that impedance at resonance is maximum and the current is minimum. The currents through the parallel branches gets magnified at resonance and is QI_0 . The circuit is inductive for $f < f_0$ and is capacitive for $f > f_0$.

If we load this parallel resonant circuit with some resistance R the effective resistance will be less than QX_{C0} . Let the resistance be $R' = Q' X_{C0}$. Therefore, Q' is smaller than Q and hence the bandwidth of the circuit is increased when the resonant circuit is shunted with the resistance R .

1.10.1 Q of Parallel RLC Circuit

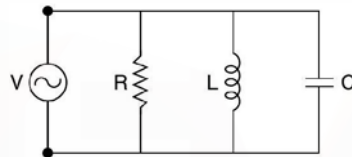

Fig. 1.24 Parallel RLC circuit.

At resonance there will be exchange of energy between the inductor and the capacitor. When the inductor is carrying maximum current, the voltage across capacitor is zero and hence the electrostatic energy is zero.

The time rate of change of energy through inductor is $\frac{V^2}{\omega_0 L}$ and the time rate of change of power is $\frac{V^2}{R}$.

Therefore,
$$Q_0 = \frac{V^2}{\omega_0 L} \cdot \frac{R}{V^2} = \frac{R}{\omega_0 L}$$

$$= \frac{V^2 \omega_0 C R}{V^2} = \omega_0 C R \quad \dots(1.41)$$

and bandwidth
$$= \frac{f_0}{Q}$$

Example 1.16. Consider Fig. E1.16 determine the original bandwidth of the circuit and the loaded circuit bandwidth.

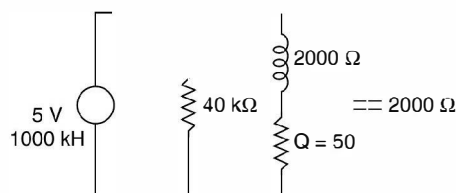

Fig. E1.16

The original equivalent circuit is

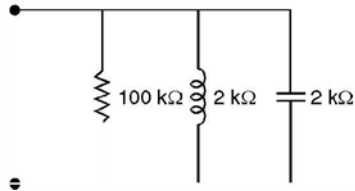

Fig. E1.16 (a)

$$Z_0 = Q X_{C0} = 50 \times 2 = 100 \text{ k}\Omega$$

The bandwidth $= \frac{f_0}{Q} = \frac{1000}{50} = 20 \text{ kHz}$

The equivalent circuit with loading resistance is

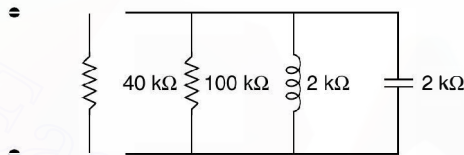

Fig. E1.16 (b)

$$Q' X_{C0} = \frac{40 \times 100}{140} = \frac{200}{7}$$

Therefore, $Q' = \frac{200}{7} \times \frac{1}{2} = \frac{100}{7}$

Therefore, bandwidth $= \frac{1000}{100} \times 7 = 70 \text{ kHz}$

It is to be noted that bandwidth in case of parallel resonance is obtained when net impedance of the circuit is 70.7% of the maximum value.

For a parallel *RLC* circuit the admittance is given as

$$Y_{in} = \frac{1}{R} + j \left(\omega C - \frac{1}{\omega L} \right) \quad \dots(1.42)$$

Since $Q_0 = \omega_0 CR$ we have

$$\begin{aligned} Y_{in} &= \frac{1}{R} + j \left(\frac{\omega \omega_0 CR}{\omega_0 R} - \frac{\omega_0}{\omega \omega_0 L} \right) \\ &= \frac{1}{R} + \frac{j}{R} \left(\frac{\omega \omega_0 CR}{\omega_0} - \frac{\omega_0 R}{\omega \omega_0 L} \right) \\ &= \frac{1}{R} \left[1 + j \left(\frac{\omega}{\omega_0} Q_0 - \frac{\omega_0}{\omega} Q_0 \right) \right] \\ &= \frac{1}{R} \left[1 + j Q_0 \left(\frac{\omega}{\omega_0} - \frac{\omega_0}{\omega} \right) \right] \quad \dots(1.43) \end{aligned}$$

Since at resonance the equivalent admittance of the circuit is $1/R$ at $1/2$ power frequencies it would be $\frac{\sqrt{2}}{R}$. Therefore, at $\frac{1}{2}$ power frequencies the imaginary quantity should be equal to unity so that

$$Y_{in} = \left| \frac{\sqrt{2}}{R} \right|$$

Therefore,

$$Q_0 \cdot \frac{\omega_1}{\omega_0} - \frac{\omega_0}{\omega_1} Q_0 = -1 \quad \dots(1.44)$$

or
$$\omega_1^2 - \omega_0^2 = -\frac{\omega_1 \omega_0}{Q_0}$$

or
$$\omega_1^2 + \frac{\omega_1 \omega_0}{Q_0} - \omega_0^2 = 0$$

or
$$\omega_1 = \frac{-\frac{\omega_0}{Q_0} + \sqrt{\left(\frac{\omega_0}{Q_0}\right)^2 + 4\omega_0^2}}{2}$$

$$= \omega_0 \left[\sqrt{\left(\frac{1}{2Q_0}\right)^2 + 1} - \frac{1}{2Q_0} \right] \quad \dots(1.45)$$

Similarly at ω_2

$$Q_0 \cdot \left[\frac{\omega_2}{\omega_0} - \frac{\omega_0}{\omega_2} \right] = 1$$

This gives on solution

$$\omega_2 = \omega_0 \left[\sqrt{\left(\frac{1}{2Q_0}\right)^2 + 1} + \frac{1}{2Q_0} \right] \quad \dots(1.46)$$

Hence bandwidth $\Delta\omega = \omega_2 - \omega_1 = \frac{\omega_0}{Q_0}$

or
$$f_2 - f_1 = \frac{f_0}{Q_0}$$

Similarly using the equations (1.45) and (1.46) it can be proved that

$$\omega_1 \omega_2 = \omega_0^2 \quad \text{or} \quad \omega_0 = \sqrt{\omega_1 \omega_2} \quad \dots(1.47)$$

Summarising the characteristics of a parallel resonance we have

1. At resonance the input impedance is maximum or the input admittance is minimum and the circuit is purely resistive and hence power factor is unity.
2. The circuit is capacitive for frequencies $f > f_0$. It is inductive for $f < f_0$.
3. The current through the inductor and capacitor are equal in magnitude but opposite in phase and the current is amplified by the factor Q , hence the current in each branch is QI_0 where I_0 is current from the source.

4. Quality factor is given as $Q_0 = \frac{R}{\omega_0 L} = \omega_0 CR$.
5. The resonance frequency when $R_L \rightarrow 0$ and $R_C \rightarrow 0$ is given by

$$f_0 = \frac{1}{2\pi\sqrt{LC}}.$$

6. Bandwidth is given as $f_2 - f_1 = \frac{f_0}{Q_0}$.
7. $f_0 = \sqrt{f_1 f_2}$ where f_1 and f_2 are the lower and upper half power frequencies respectively.

Example 1.17. Show that the sum of energy stored by the inductor and the capacitor connected in series at resonance at any instant is constant and is given by LI^2 .

Solution: Let i and v be the instantaneous current through inductor and the voltage across the capacitor at any time t .

Let $i = I_m \cos \omega_0 t$

The energy stored is $\frac{1}{2} Li^2 = \frac{1}{2} LI_m^2 \cos^2 \omega_0 t$

The energy stored in the capacitor $\frac{q^2}{2C} = \frac{1}{2C} \left[\int_0^t i dt \right]^2$

$$= \frac{1}{2C} \cdot I_m^2 \left[\int_0^t \cos \omega_0 t dt \right]^2$$

$$= \frac{1}{2C} I_m^2 \left[\left(\frac{\sin \omega_0 t}{\omega_0} \right)_0^t \right]^2$$

$$= \frac{I_m^2}{2} L \sin^2 \omega_0 t$$

Therefore total energy

$$= \frac{1}{2} LI_m^2 (\cos^2 \omega_0 t + \sin^2 \omega_0 t)$$

$$= \frac{1}{2} I_m^2 L$$

$$= LI^2$$

Example 1.18. Show that the sum of energy stored by the inductor and the capacitor in a parallel RLC circuit at any instant is constant at resonant frequency and is equal to CV^2 .

Solution: Let $v = V_m \cos \omega_0 t$

The energy stored by the capacitor is

$$= \frac{1}{2} CV_m^2 \cos^2 \omega_0 t$$

The energy stored by the inductor is $\frac{1}{2} Li^2$

Now

$$v = L \frac{di}{dt}$$

$$di = \frac{v}{L} dt$$

$$i^2 = \left(\int \frac{v}{L} dt \right)^2$$

$$= \frac{V_m^2}{L^2} \cdot \frac{\sin^2 \omega_0 t}{\omega_0^2} = \frac{V_m^2}{L^2} \cdot \sin^2 \omega_0 t LC$$

$$i^2 = \frac{V_m^2 C}{L^2} \sin^2 \omega_0 t$$

Energy

$$= \frac{1}{2} LC^2 = \frac{1}{2} L \cdot \frac{V_m^2 C}{L} \sin^2 \omega_0 t$$

$$= \frac{C}{2} V_m^2 \sin^2 \omega_0 t$$

Therefore total energy = $\frac{1}{2} C V_m^2 = CV^2$. Hence proved.

Example 1.19. A coil having a resistance of 50Ω and inductances 10 mH is connected in series with a capacitor and is supplied at constant voltage and variable frequency source. The maximum current is 1 A at 750 Hz . Determine the bandwidth and half power frequencies.

Solution: Q of the coil = $\frac{\omega_0 L}{R} = \frac{2\pi \times 750 \times 10 \times 10^{-3}}{50}$

$$= 0.9425$$

Bandwidth = $\frac{f_0}{Q} = \frac{750}{0.9425} = 795.8 \text{ Hz}$

i.e. $f_2 - f_1 = 795.8 \text{ Hz}$

and $f_0 = \sqrt{f_1 f_2}$

$$750^2 = f_1 f_2$$

$$(f_2 + f_1)^2 = 795.8^2 + 4 \times 750^2$$

$$= 1697.8^2$$

or $f_2 + f_1 = 1697.8$

$$f_2 - f_1 = 795.8$$

$$2f_2 = 2493.6$$

$$f_2 = 1246.8 \text{ Hz}$$

and $f_1 = 451 \text{ Hz}$.

Example 1.20. Two branches of a parallel circuit have element $R_L = 6 \Omega$ $L = 1 \text{ mH}$ and $R_C = 4 \Omega$ and $C = 20 \mu\text{F}$. Determine the frequency of resonance. Also determine the maximum value of R_C for which resonance can occur.

Solution: We know that for such a circuit

$$\omega_0 = \frac{1}{\sqrt{LC}} \cdot \sqrt{\frac{R_L^2 - L/C}{R_C^2 - L/C}}$$

$$\begin{aligned}
 &= \sqrt{\frac{1}{1 \times 10^{-3} \times 20 \times 10^{-6}}} \cdot \sqrt{\frac{6^2 - \frac{10^{-3}}{20 \times 10^{-6}}}{4^2 - \frac{10^{-3}}{20 \times 10^{-6}}}} \\
 &= \frac{10^4}{\sqrt{200}} \sqrt{\frac{14}{34}} \\
 &= 4537 \text{ rad/sec.}
 \end{aligned}$$

In order for resonance to take place the quantity within the square root sign should be positive. Since $R_L^2 < \frac{L}{C}$, R_c^2 should also be less than $\frac{L}{C}$ or $R_c < \sqrt{\frac{L}{C}}$ or $R_c < 7.07 \Omega$ **Ans.**

Example 1.21. In the problem of example 1.20 if $R_c = 5 \Omega$ and R_L is variable, the circuit is fed from a sinusoidal source at a frequency f such that $X_c = 6 \Omega$ and $X_L = 15 \Omega$. Determine the value of R_L for which resonance can take place.

Solution: At resonance

$$X_c - X_L = R_c^2 - R_L^2 = 5^2 - R_L^2 = 25 - R_L^2 = 0$$

$$\text{or } \frac{5}{61} - \frac{15}{R_L^2 + 225} = 0$$

$$\text{or } R_L^2 + 225 = 183$$

$$\text{or } R_L^2 = -42$$

This means R_L should be negative which is not possible. Hence no value of R_L will be able to bring resonance in the circuit at the given condition.

Example 1.22. A coil has an inductance of 1.3 mH and resonates at 600 KHz and its $Q = 30$. If the bandwidth required is 50 KHz what resistor should be connected across the coil?

Solution: The reactance of the coil $= 2\pi(600 \times 10^3) \times 1.3 \times 10^{-3}$
 $= 4900 \Omega$

Since at resonance $X_{L0} = X_{C0}$
 $X_{C0} = 4900$

The input resistance $= Z_{T0} = QX_{C0}$
 $= 30 \times 4900$
 $= 147000 \Omega$

The required bandwidth is 50 kHz

Therefore, required Q of the circuit is $\frac{f_0}{50}$
 $= \frac{600}{50} = 12$

The equivalent input resistance required is
 $Z'_{T0} = Q X_{C0} = 12 \times 4900$
 $= 58800$

The resistance required for shunting is say R'

$$58800 = \frac{147000R'}{147000 + R'}$$

or $147000 \times 58800 = 147000R' - 58800R'$

or
$$R' = \frac{147000 \times 58800}{88200}$$

$$= 98 \text{ k}\Omega. \text{ Ans.}$$

1.11 MAGNETIC CIRCUITS

Oersted in 1819 discovered that a current flowing in a straight conductor deflected the needle of a compass and it shows that the paths of magnetic force are concentric circle around the conductor. Similarly if a current is passed through circular (loop) conductor the magnetic flux are found to be concentric to the circular conductor and the magnetic flux density at the centre of the circular conductor is given by (loop)

$$B = \frac{\mu I}{2r}$$

where B is the magnetic flux density in Wb/m^2 or in Tesla, I the current flowing through the circular loop of the conductor and r the radius of the circular loop, μ the permeability of the material around which the loop is wound.

$$\mu = \mu_0 = 4\pi \times 10^{-7} \text{ H/m}$$

if the coil is wound on a non-magnetic material or it is air cored and $\mu = \mu_0 \mu_r$,

where μ_r is the relative permeability of the magnetic material. The magnetic flux density is related to magnetic field intensity through μ as given below.

$$B = \mu_0 \mu_r H$$

where H is the magnetic field intensity and its units are Ampere turns per meter. μ_r has no units as it is a relative permeability, μ is permeability of the material and its units are Henry/m.

We know that the electrostatic potential V and electric field intensity are related by

$$E = -\nabla V$$

Similarly, the scalar magnetic potential V_m is related to magnetic field intensity H as

$$H = -\nabla V_m$$

In dealing with magnetic circuits it is convenient to call V_m the magnetomotive force or mmf as it has analogy with electromotive force in electric circuits. Just as an electromotive force drives the electric current or conventional current through a conductor the magnetomotive force similarly creates and drives magnetic flux through a magnetic material or in space. The units of mmf are ampere-turns when current is passed through N no. of coils or turns of a conductor.

The electric potential difference between two points is given as

$$V_{ab} = \int_a^b E \cdot dl$$

Similarly, if we consider a current carrying conductor (current going into the paper), this gives rise to magnetic

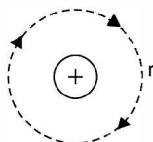

Fig. 1.24(a) Magnetic Field due to a current carrying conductor.

field or magnetic flux which encircle the conductor clockwise. The direction of flux lines is given by cork-screw rule or Fleming right-hand thumb rule. If the screw is pushed into the cork (driven into the paper) then screw should be moved clockwise and hence the direction of flux line shown in Fig. 1.24(a). Similarly according to Fleming right hand thumb rule means if we hold our thumb in the direction of flow of current; here normal and into the paper the twist in the fingers gives the direction of flux lines on the surface of the paper.

Now magnetic field intensity at a distance r from the centre of the conductor is given as

$$H = \frac{I}{2\pi r}$$

and if there are N such conductors, then

$$H = \frac{NI}{2\pi r}.$$

The line integral of H over the complete line here a circle of radius r will give

$$\oint \frac{NI}{2\pi r} dl = NI = V_{mab}$$

and its units are ampere turns and thus is known as magnetomotive force. The above integrated equation is known as Ampere's circuital law and V_{mab} denotes the ampere turns enclosed by the assumed closed flux line path.

However, in an electric circuit the voltage source is a part of the closed path, in the magnetic circuit the current carrying coil will surround or link the magnetic circuit. In tracing a magnetic circuit we will not be able to identify a pair of terminals at which the magnetomotive force (mmf) is applied.

1.11.1 Analogies between Magnetic and Electric Circuits

As far as analysis of magnetic circuits is concerned, it is analogous to electric circuits. The analogous quantities are listed below.

Electric Circuits

e.m.f. (Volts)

Current (Ampere)

Resistance, ohm

Magnetic Circuits

mmf (amp. Turns)

Flux (Webers)

Reluctance, R

Conductance S	Permeability Henry/m
Electric field intensity, E V/m	Magnetic field Intensity, H AT/m
Electric flux density D coulomb/m ²	Magnetic flux density Wb/m ²

Simple magnetic circuits can be analysed based on Ohm's law in electric circuits according to Ohm's law

$$\frac{V}{I} = R$$

where V is the e.m.f., I the current and R the resistance. Picking up analogous quantities in magnetic circuits from the relations given above we have

$$\frac{mmf}{flux} = \text{Reluctance}$$

$$\frac{NI}{\phi} = \text{Reluctance}$$

where N is the number of turns in the circular coil.

Now $\phi = BA$ where A is the area of cross section of the core on which the coil is wound.

$$\text{Now } B = \mu_0 \mu_r H$$

and $H = \frac{NI}{l}$ where l is the length of the magnetic path.

$$\begin{aligned} \text{Hence reluctance } R &= \frac{NI}{\mu_0 \mu_r \frac{NI}{l} \cdot A} \\ &= \frac{l}{\mu_0 \mu_r A} \text{ AT/Wb} \end{aligned}$$

In electric circuit, the emf drives current to flow which is limited by the resistance of the path of the current, in magnetic circuit, mmf creates and drives flux through a magnetic circuit but the flux value is limited by what is known as reluctance of the magnetic circuit which is defined by the above expression. No specific name is given to the dimension of reluctance except to refer it to as so many units of reluctance.

From the above expression for reluctance it is found that the impediment to the flow of flux which a magnetic circuit presents is directly proportional to the length and inversely proportional to the permeability and cross-sectional area. The results are in consistence which the actual physical conditions.

Series Magnetic Circuit

If there are one or more than one magnetic paths connected in series there could even be an air gap in the path of the same flux (same current in a series electric circuit), the net reluctance is the sum total of the individual magnetic paths.

Parallel Magnetic Circuits

Analogous to electric circuit, the magnetic circuit will be analysed using Kirchhoff's laws as shown in Fig. 1.25.

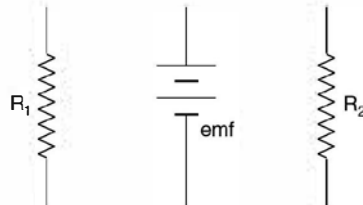

Fig. 1.25. Analogous parallel electric circuits.

Let us take a few examples to illustrate the application of what we have studied about the magnetic circuits.

Example 1.23. An iron ring of mean length 50 cms has an air gap of 1 mm and a winding of 200 turns. If the relative permeability of air is 300 when a current of 1 A flows through the coil, find the flux density.

Solution.

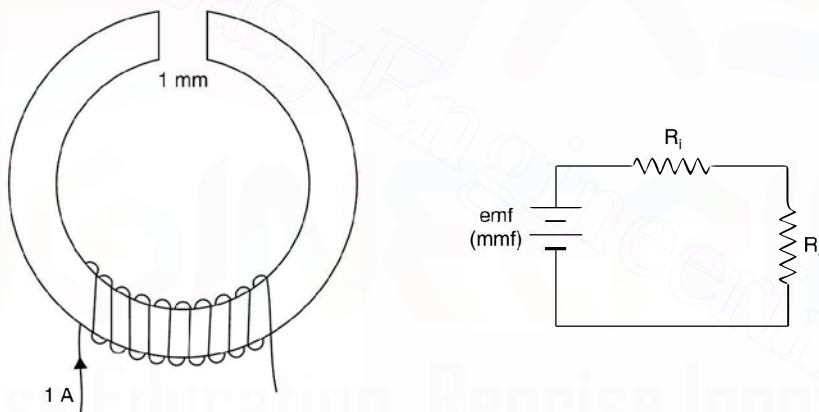

Fig. E1.23. (a) Magnetic Circuit (b) Electric analog.

The reluctance of magnetic path R ,

$$\begin{aligned} &= \frac{50 \times 10^{-2}}{4\pi \times 10^{-7} \times 300 A} \\ &= \frac{50 \times 1000}{12\pi A} = \frac{1326}{A} \end{aligned}$$

Now reluctance of air gap R_2

$$R_2 = \frac{1 \times 10^{-3}}{4\pi \times 10^{-7} \times 1 \times A} = \frac{796}{A} \quad \text{as } \mu_r = 1 \text{ for air}$$

$$\text{Total reluctance} = \frac{1326}{A} + \frac{796}{A} = \frac{2122}{A}$$

$$\begin{aligned}\phi &= \frac{MMF}{\text{Reluctance}} = \frac{200 \times 1A}{2122} \\ &= 94.2 \times 10^{-3} A\end{aligned}$$

or
$$B = \frac{\phi}{A} = 94.2 \text{ mwb/m}^2 \quad \text{Ans.}$$

Example 1.24. A cast steel electromagnet has an air gap of length 2 mm and an iron path of length 30 cms. Find the number of ampere turns necessary to produce a flux density of 0.8 wb/m² in the air gap. Assume $H = 700 \text{ AT/m}$ for the flux density of 0.8 wb/m² for the cast steel.

Solution. Here again there are two reluctances in series, one due to cast steel (say R_1) and the other due to air gap (say R_2)

$$R_1 = \frac{30 \times 10^{-2}}{4\pi \times 10^{-7} \mu_r A}$$

Since

$$\begin{aligned}B &= \mu_0 \mu_r H \\ 0.8 &= 4\pi \times 10^{-7} \mu_r \times 700 \\ \mu_r &= 910\end{aligned}$$

Hence

$$R_1 = \frac{30 \times 10^{-2}}{4\pi \times 10^{-7} \times 910 A} = \frac{262.4}{A}$$

and

$$R_2 = \frac{2 \times 10^{-3}}{4\pi \times 10^{-7} \times 1 \times A} = \frac{1592}{A}$$

Hence total reluctance

$$= \frac{1592 + 262.4}{A} = \frac{1854.4}{A}$$

Now

$$\phi = \frac{NI}{R}$$

$$0.8 \times A = \frac{NI \cdot A}{1854.4}$$

or
$$NI = 1854.4 \times 0.8 \simeq 1485 \text{ AT} \quad \text{Ans.}$$

Example 1.25. Fig. E1.12(a) shows a three limb electromagnetic circuit. The central limb has an air gap of 2 mm. Assume $\mu_r = 800$, determine the current in the 600 turn exciting coil to establish a flux of $100 \times 10^{-3} \text{ mwb}$ in the air gap.

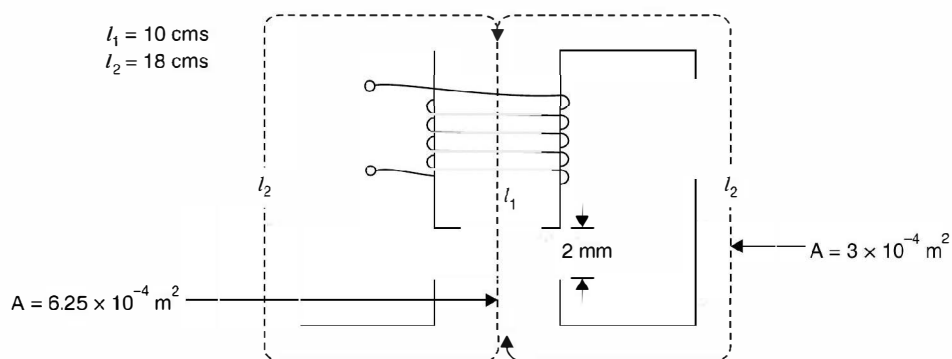

Fig. E1.25(a)

Solution. Since the flux in the air gap is 100×10^{-3} mwb, the flux in the outer limbs will be 50×10^{-3} mwb. The analogous electric circuit is as shown.

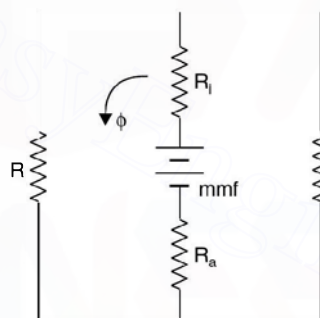

Fig. E1.25(b)

$$R_a = \frac{2 \times 10^{-3}}{4\pi \times 10^{-7} \times 6.25 \times 10^{-4}}$$

$$= 25.47 \times 10^5$$

$$R_i = \frac{10 \times 10^{-2}}{4\pi \times 10^{-7} \times 800 \times 6.25 \times 10^{-4}}$$

$$= 159200 = 1.592 \times 10^5$$

$$= 27.062 \times 10^5$$

Total reluctance

Hence

$$mmf = \phi R = 100 \times 10^{-6} \times 27.062 \times 10^5$$

$$= 27.06 \times 10 = 270.6$$

Reluctance of one of the parallel paths

$$= \frac{18 \times 10^{-2}}{4\pi \times 10^{-7} \times 800 \times 3 \times 10^{-4}}$$

$$= \frac{18 \times 10^9}{4\pi \times 800 \times 3} = 5.97 \times 10^5$$

Hence *mmf* required for one of the parallel paths is $50 \times 10^{-6} \times 5.97 \times 10^5$
 $= 29.85$

Hence total *mmf* $270.6 + 29.85 = 300.45 \text{ AT}$

$$\text{The current} = \frac{300.45}{600} \simeq 0.5 \text{ A} \quad \text{Ans.}$$

We have taken one of the parallel paths as, to find out *mmf* (e.m.f. in electrical analog) we need complete one loop.

Example 1.26. A 680 turn coil is wound on the central limb of the cast steel frame shown. A total flux of 1.6 mwb is required in the gap. Find the current required. Dimensions are in cms. Assume $H = 900 \text{ A T/m}$ for $B = 1 \text{ Wb/m}^2$.

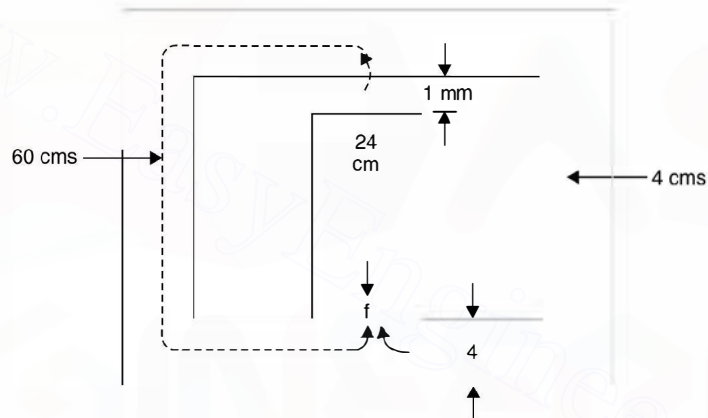

Fig. E1.26

Solution.

$$B = \mu_0 \mu_r H$$

$$1 = 4\pi \times 10^{-7} \mu_r \times 900$$

or
$$\mu_r = \frac{10^5}{4\pi \times 9} = 885$$

$$\text{Reluctance for the air gap} = \frac{1 \times 10^{-3}}{4\pi \times 10^{-7} \times 1 \times 16 \times 10^{-4}}$$

$$= \frac{10^8}{4\pi \times 16} = 497610 \text{ AT/Wb}$$

$$\text{Reluctance of the central limb} = \frac{24 \times 10^{-2}}{4\pi \times 10^{-7} \times 885 \times 16 \times 10^{-4}}$$

$$= \frac{24 \times 10^9}{4\pi \times 885 \times 16} = 13.49 \times 10^4 \text{ AT/Wb}$$

Total reluctance of the central limb

$$= 63.25 \times 10^4 \text{ AT/Wb}$$

MMf required for the central limb

$$= 63.25 \times 10^4 \times 1.6 \times 10^{-3} \\ = 1012 \text{ AT}$$

Now reluctance of one of the outer limbs

$$13.49 \times 10^4 \times \frac{60}{24} = 33.72 \times 10^4$$

Hence AT required

$$= 33.72 \times 0.8 \times 10^{-3} \times 10^4 \\ = 269.8$$

$$\text{Total AT required} = 1012 + 269.8 = 1281.8$$

Since the two paths are identical it is necessary to consider mmf for only one of them.

Hence total mmf required

$$1012 + 269.8 = 1281.8$$

$$\text{Hence current required} = \frac{1281.8}{680} = 1.9 \text{ Amp.}$$

1.11.2 Leakage Flux

In order to understand the concept of leakage flux refer to Fig. 1.26.

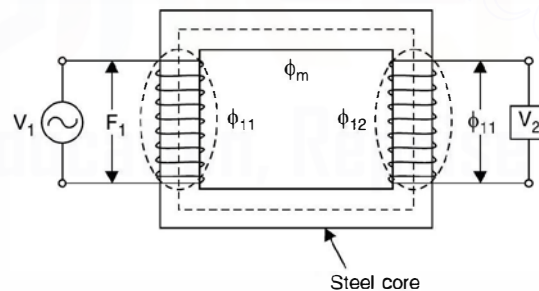

Fig. 1.26 Leakage flux.

As we connect voltage source across primary, current is drawn by the primary winding depending upon the state of secondary. If the secondary winding is open it draws current corresponding to exciting current which gives rise to magnetic flux in the steel core and meets the core loss requirements. The steel core is carefully designed to keep the magnetic flux contained within the steel core. Any magnetic flux that is outside the confines of the magnetic steel core is termed as leakage flux. In Fig. 1.26 ϕ_{11} and ϕ_{12} are the leakage fluxes of primary and secondary winding respectively as these fluxes are flowing and completing their path

through air rather than steel core. ϕ_m is the flux which is linking both the windings and is known as mutual flux or common flux.

The total flux linking the primary winding is divided into two components (i) the resultant mutual flux confined essentially to the steel core and produced by the combined effect of the primary and secondary currents (if secondary is loaded) and (ii) the primary leakage flux which links only the primary. These components have been identified in the basic transformer in Fig. 1.26 where for simplicity the primary and secondary windings are shown on separate (opposite) legs of the core. In an actual transformer with interleaved windings (usually low voltage winding is placed near the core and then sufficient insulation is provided and high voltage is placed above the primary *i.e.*, both the limbs have primary as well as secondary winding), the details of the flux map are more complicated but the essential features remain the same. Since the leakage path is mainly through the air, the leakage flux and the voltage induced by it vary linearly with primary current. The effect on the primary circuit is simulated by assigning to the primary a leakage inductance which by definition is equal to leakage flux linkage (leakage flux \times No. of turn of primary) per unit primary current or it is equivalent to leakage reactance *i.e.* $2\pi f \times$ leakage inductance.

Similarly the effect of secondary leakage flux can be simulated on the secondary winding of the transformer.

1.11.3 Fringing of Flux

To understand fringing of magnetic flux consider Fig 1.27. In the air gap the magnetic flux line bulge outwards somewhat as shown in Fig. 1.27 this is known as fringing of flux. The effect of the fringing is to increase the cross sectional area of air gap. The flux density in the air gap reduce as compared to one in the core therefore, a correction due to fringing is required. The usual correction is to add the gap dimension to each dimension of air gap *e.g.* if the core dimensions are 3 cm by 3 cm and air gap g is 0.05 cm, the corrected area would be $A_g = (3 + 0.05)(3 + 0.05) = 9.3 \text{ cm}^2$, thereby the gap reluctance decreases by about 3% for the uncorrected gap.

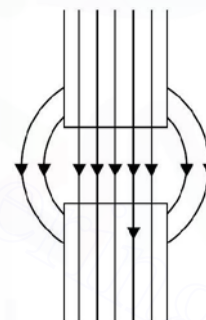

Fig. 1.27 Fringing flux.

1.12 DOT CONVENTION FOR COUPLED CIRCUITS

The significance of dot convention is explained with the help of Fig. 1.28.

Suppose a time varying voltage source is connected across the primary of the transformer and at any given instant the voltage source has the polarity shown and current $i(t)$ is in the direction shown by the arrow and is increasing with time entering the dotted terminal, this current induces a voltage in the secondary which is positive at the dotted terminal.

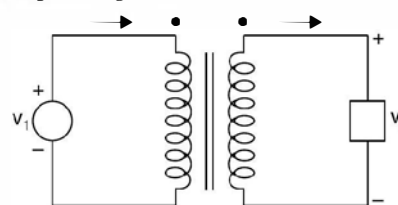

Fig. 1.28. A circuit for dot convention.

Conversely if the current in the primary is increasing and is leaving the dotted terminal this will induce the voltage polarity in the secondary such that the undotted end will become positive and hence dotted terminals of both the windings will be negative simultaneously. The following experimental procedure can be used to establish dotted ends of the transformer windings. Mark a dot arbitrarily on one end of the primary winding and connect a d.c. source with positive terminal connected to the dotted end and the negative terminal to the undotted end of the winding through a switch. Connect a MC voltmeter across the secondary winding. The end of the secondary winding which goes positive momentarily on closing the switch on the primary side as measured by the voltmeter, is the terminal to be dotted.

If there are more than two windings, similar procedure can be followed for identifying relationship between each pair of windings. For each pair of winding different forms of dots (\cdot \diamond \blacksquare \otimes) should be used to avoid any confusion.

Suppose we are required to write loop equations for a mutually coupled circuit shown in Fig. 1.29.

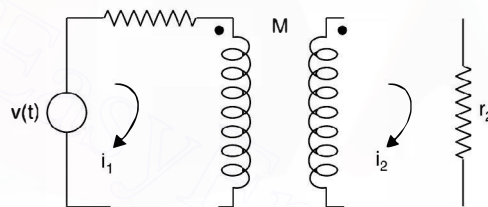

Fig. 1.29. Coupled circuit.

For primary loop the drops are $i_1 r_1 + L_1 \frac{di_1}{dt}$ + drop in primary loop due to current in secondary loop. The voltage induced in primary will be determined by the direction of i_2 with respect to its dot in secondary loop. Since current is going away from the dot, the polarity of voltage on the primary side will be positive at the undotted terminal. Therefore, for current i_1 it will be rise in voltage and the equation will be

$$i_1 r_1 + L_1 \frac{di_1}{dt} - M \frac{di_2}{dt} = v(t)$$

and for the secondary loop, similarly

$$i_2 r_2 + L_2 \frac{di_2}{dt} - M \frac{di_1}{dt} = 0$$

The equivalent two loops are as shown in Fig. 1.30.

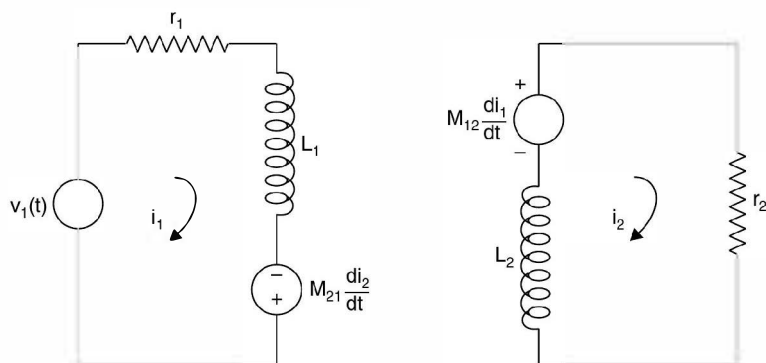

Fig. 1.30. Equivalent of Fig. 1.29.

Consider Fig. 1.31 which is a magnetically coupled network.

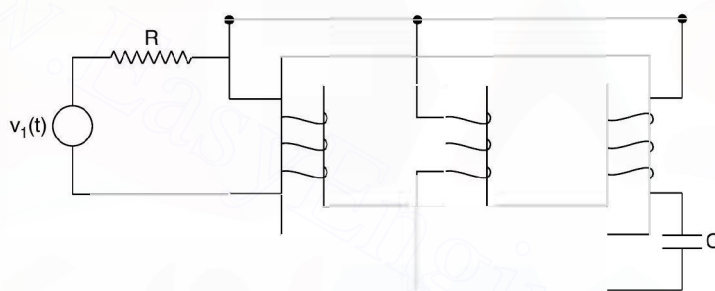

Fig. 1.31. Magnetically coupled network.

The equivalent with dots is given in Fig. 1.32.

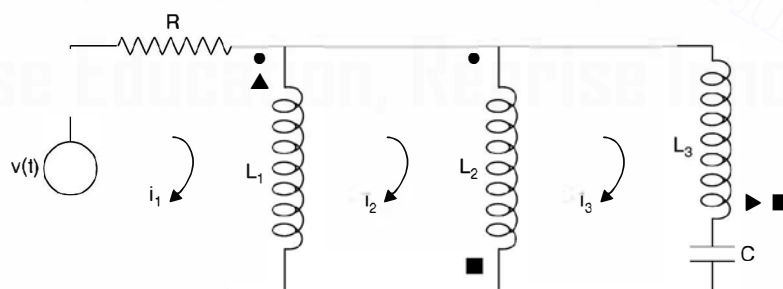

Fig. 1.32. Equivalent of Fig. 1.31.

Since all the three coils are mutually coupled, each coil will induce voltage in the other two coils, the magnitude will depend upon the current flowing through the coil and the polarity its relative direction of flow with respect to dot of the coil.

Voltage induced in coil 1

Due to coil 2, the current through coil 2 is $(i_2 - i_3)$ entering the circular dot, therefore the voltage induced in coil 1 will be with positive polarity at the dot. Due to coil 3, since the current i_3 is leaving the triangular dot, the polarity will be -ve at the corresponding dot in coil 1.

Voltage induced in coil 2

Due to coil 1, the current $(i_1 - i_2)$ enters the dot, therefore positive polarity at the dot of coil 2.

Due to coil 3, the current i_3 leaves the dot (square), the polarity +ve will be at the undotted terminal of coil 2.

Voltage induced in coil 3

Due to coil 1 the current entering the dot is $(i_1 - i_2)$ hence the positive polarity at the dotted terminal of coil 3. Due to coil 2 current $(i_2 - i_3)$ leaves the dot (square), the positive polarity will be at the undotted terminal. Hence the equivalent circuit given as follows :

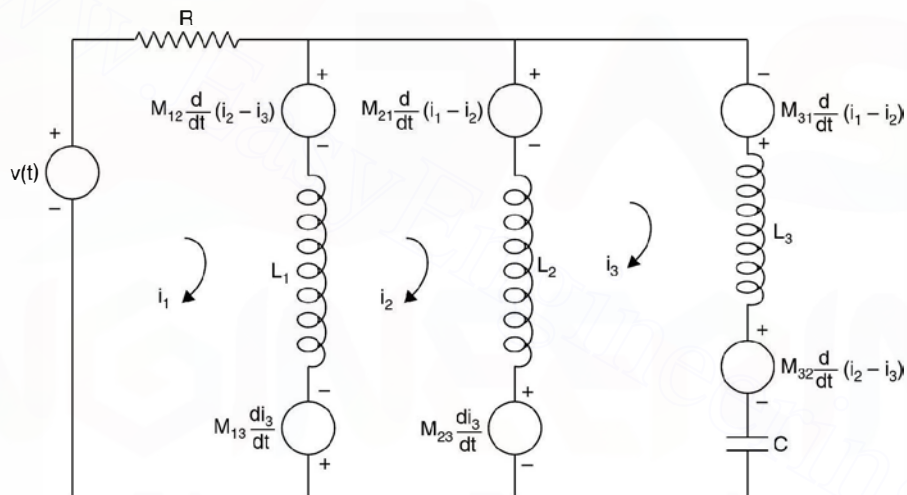

Fig. 1.33. Equivalent of Fig. 1.29 with voltage sources.

The loop equations can be written as follows :

Loop 1

$$Ri_1 + M_{12} \frac{d(i_2 - i_3)}{dt} + L_1 \frac{d(i_1 - i_2)}{dt} - M_{13} \frac{di_3}{dt} = v(t)$$

Loop 2

$$M_{13} \frac{di_3}{dt} + L_1 \frac{d(i_2 - i_1)}{dt} - M_{12} \frac{d(i_2 - i_3)}{dt} + M_{21} \frac{d(i_1 - i_2)}{dt} + L_2 \frac{d(i_2 - i_3)}{dt} + M_{23} \frac{di_3}{dt} = 0$$

Loop 3

$$L_2 \frac{d(i_2 - i_3)}{dt} - M_{23} \frac{di_3}{dt} - M_{21} \frac{d(i_1 - i_2)}{dt} - M_{31} \frac{d(i_1 - i_2)}{dt} + L_3 \frac{di_3}{dt} + M_{32} \frac{d(i_2 - i_3)}{dt} + \frac{1}{C} \int i_3 dt = 0$$

The above example explains clearly how voltage sources (corresponding to induced voltages) are inserted in the coils which are magnetically coupled and the dots have been assigned.

When the two coils are to be interconnected it is important to know whether the mutual inductance M is aiding or opposing. However, it is known that the effect on each of the two coils must be the same. Refer to Fig. 1.34(a) where the mutual inductance is aiding their self inductances whereas in (b) it is opposing. If L_1 and L_2 are the self inductances of the two coils and M the mutual inductance, the total inductance say if is L_A in case of Fig. 1.32(a) and L_B that in Fig. 1.32(b) then,

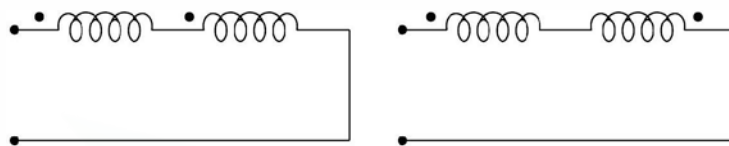

Fig. 1.34. (a) Two coils aid and (b) Oppose.

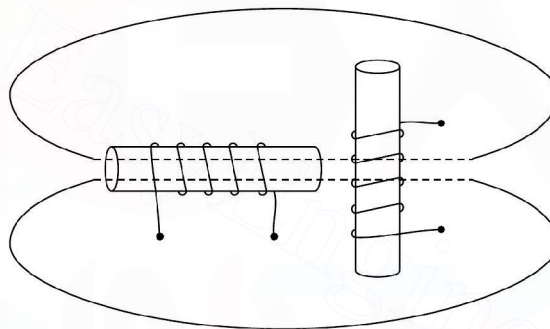

Fig. 1.35. The coils at right angles.

$$L_A = L_1 + L_2 + 2M$$

$$L_B = L_1 + L_2 - 2M$$

and

Therefore,
$$M = \frac{L_A - L_B}{4}$$

This method provides a very convenient way of determining the value of mutual inductance between the coils.

The co-efficient of coupling and the mutual inductance between the two coils shown in Fig. 1.33 are both zero. Although the flux of one coil appears to pass through the other coil, it does not actually link the turns of the other coil.

Therefore, the linkages are zero and the value of M is zero. It is only when one coil is rotated with respect to other that a linking occurs.

Example 1.27. Determine the inductance of the individual winding and the equivalent inductance when mutual inductance is $8H$.

Since the flux through the two coils opposes each other, the mutual inductance is subtractive from each coil and hence

$$L_1 = 15 - 8 = 7\text{H}$$

and

$$L_2 = 16 - 8 = 8\text{H}$$

Therefore equivalent inductance between the terminals

$$L = \frac{L_1 L_2}{L_1 + L_2} = \frac{7 \times 8}{15} = 3.73\text{H}$$

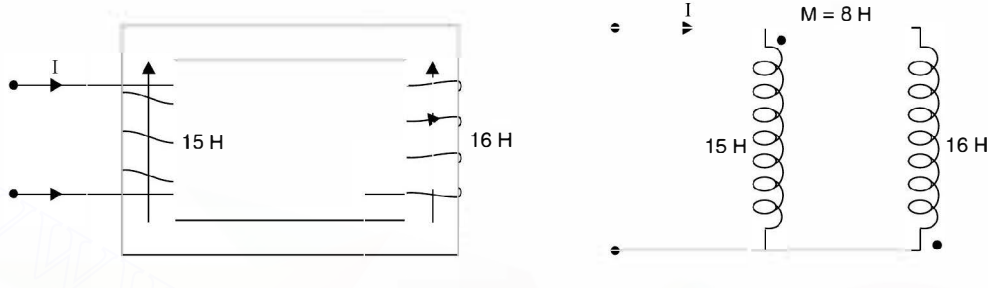

Fig. E1.27

Example 1.28. Determine the inductance between the terminals for a three coil system shown below:

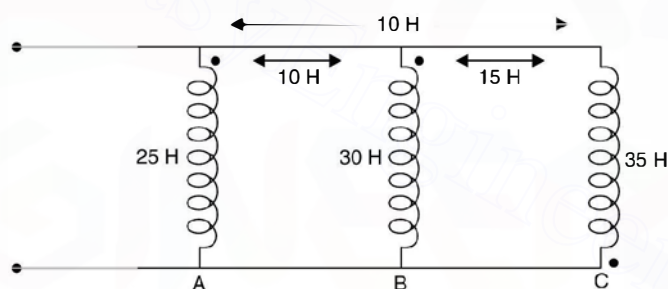

Fig. E1.28

From the Fig. 15

$$L_A = 25 + 10 - 10 = 25\text{H}$$

$$L_B = 30 + 10 - 15 = 25\text{H}$$

$$L_C = 35 - 15 - 10 = 10\text{H}$$

Therefore,

$$\frac{1}{L_{eq}} = \frac{1}{25} + \frac{1}{25} + \frac{1}{10} = \frac{2+2+5}{50}$$

or

$$L_{eq} = \frac{50}{9} = 5.55\text{H}$$

Example 1.29. A sinusoidally varying alternating current of frequency 50 Hz has a maximum value of 20 A.

- (i) Write down the equation for the instantaneous value.
 (ii) Determine the value of current after 1/100 sec.
 (iii) Determine the time taken to reach 10 A for the first time.
 (iv) Determine the average and the rms value.

Solution: The general expression is

$$i(t) = I_m \sin \omega t \text{ where } \omega = 2\pi f \\ = 2\pi \times 50 = 314$$

- (i) Hence the instantaneous value of the current is given as

$$i(t) = 20 \sin 314t$$

- (ii) Substituting $t = 1/100$ we have

$$i(t) = 20 \sin \frac{314}{100} = 20 \sin 3.14 \\ = 20 \sin \pi = 0. \quad \text{Ans.}$$

- (iii) $10 = 20 \sin 314t$
 or $\sin 314t = 0.5$

$$= \sin \frac{\pi}{6}$$

- or $314t = \frac{\pi}{6}$ or $t = \frac{\pi}{314 \times 6} = 0.00166 \text{ sec.} \quad \text{Ans.}$

- (iv) The average value of this sinusoidal wave over complete cycle is zero. **Ans.**

The rms value is given as $\frac{I_m}{\sqrt{2}} = \frac{20}{\sqrt{2}} = 14.14 \text{ A.} \quad \text{Ans.}$

Example 1.30. Two alternating currents are represented by

$$i_1(t) = 20 \sin (314t + 30^\circ)$$

and

$$i_2(t) = 40 \sin (314t + 45^\circ)$$

Determine the resultant current $i(t) = i_1(t) + i_2(t)$.

Solution: $i_1(t) = 20 \sin (314t + 30^\circ)$

and $i_2(t) = 40 \sin (314t + 45^\circ)$

The two phasors are represented as shown here.

Resolving the two currents along x and y-axes.

We have

$$20 \cos 30^\circ + j20 \sin 30^\circ \\ = 10\sqrt{3} + j10$$

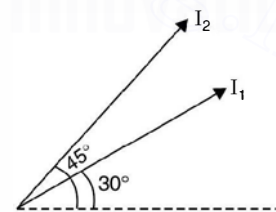

Fig. E1.30

and

$$\begin{aligned} i_2 &= 40 \cos 45^\circ + j 40 \sin 45^\circ \\ &= \frac{40}{\sqrt{2}} + j \frac{40}{\sqrt{2}} \end{aligned}$$

Adding the x and y components we have

$$\begin{aligned} &\left(10\sqrt{3} + \frac{40}{\sqrt{2}} \right) + j \left(10 + \frac{40}{\sqrt{2}} \right) \\ &(17.32 + 28.28) + j(10 + 28.28) \end{aligned}$$

The resultant current is (maximum value) is

$$\sqrt{45.6^2 + 38.28^2} = 59.54 \text{ A}$$

and its phase angle is $\phi = \tan^{-1} \frac{38.28}{45.6} = 40^\circ$

Hence $i(t) = 59.54 \angle 40^\circ$.

Example 1.31. Two sinusoidally varying voltages are given as

$$v_1 = 110 \sin \omega t \quad \text{and} \quad v_2 = 80 \sin (\omega t - \pi/6)$$

Determine the expressions of voltage for (i) sum and (ii) difference of the two voltages.

Solution: (i) Taking v_1 as reference i.e., x component is 110 volts and x component of v_2 is

$$80 \cos 30 = \frac{80\sqrt{3}}{2} = 40\sqrt{3}$$

and y component $80 \sin 30 = 40$

Hence the sum of the two voltages peak value

$$(110 + 40\sqrt{3}) + j 40$$

Hence $V_{max} = \sqrt{(110 + 40\sqrt{3})^2 + 40^2} = 183.7 \text{ volt}$

and phase $\phi = \tan^{-1} \frac{40}{179.3} = 12.57^\circ$

Hence $v(t) = 183.7 \sin (\omega t - 12.57^\circ)$ **Ans.**

Here y component is $-ve$ as $y = 110 \sin 0^\circ - 80 \sin \pi/6 = -40$

(ii) The V_{max} for difference of two voltages is

$$\sqrt{(110 - 40\sqrt{3})^2 + 40^2} = 57 \text{ volts}$$

and phase $\phi = \tan^{-1} \frac{40}{40.72} = 44.5^\circ$

Hence $v(t) = 57 \sin (\omega t + 44.5^\circ)$

Here y component is positive as

$$y = 110 \sin 0 - 80 \sin \frac{-\pi}{6} = 0 + 80 \sin \frac{\pi}{6} = 40$$

Example 1.32. The voltage applied to a circuit is $v = 230 \sin(\omega t + 30^\circ)$ and the current through the circuit is $i = 10 \sin(\omega t - 30^\circ)$. Determine the parameters of the circuit, power consumed in the circuit and p.f. of the circuit.

Solution: (i) The impedance of this circuit is

$$z = \frac{v}{i} = \frac{230}{10} = 23 \Omega$$

and since the current is lagging the voltage, it is an inductive circuit and the impedance angle is $30 + 30 = 60^\circ$. The impedance triangle is shown here

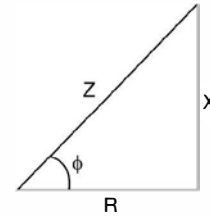

Fig. E1.32

Hence $R = z \cos \phi = 23 \cos 60 = 11.5 \Omega$

and $X = 23 \sin 60^\circ = 23 \times \frac{\sqrt{3}}{2} = 19.9 \Omega$

(ii) $P = VI \cos \phi = \frac{230}{\sqrt{2}} \cdot \frac{10}{\sqrt{2}} \cos 60^\circ = 575 \text{ watts}$

and p.f. of the circuit is $\cos 60 = 0.5$ **Ans.**

Example 1.33. An iron cored coil takes 5 A when connected to 40 V dc supply and takes 5 A when connected to 200 V ac supply and consumes 500 watts. Determine (i) the impedance (ii) the iron loss (iii) the inductance of the coil (iv) p.f. of the coil.

Solution: When coil is connected to dc supply it offers only resistance (d.c. resistance)

and hence the resistance of the coil is $\frac{40}{5} = 8 \Omega$ and the impedance of the coil is $\frac{200}{5} = 40 \Omega$.

$$\begin{aligned} \text{The iron loss} &= \text{Total loss} - \text{Power loss in ohmic resistance} \\ &= 500 - 5^2 \times 8 \\ &= 500 - 200 = 300 \text{ watts} \end{aligned}$$

$$\text{The effective resistance of the coil} = \frac{P}{I^2} = \frac{500}{5^2} = 20 \Omega$$

Hence inductive reactance

$$\sqrt{40^2 - 20^2} = 34.6 \Omega$$

$$\text{The inductance of coil} = \frac{34.6}{314} = 0.11 \text{ H} \quad \text{Ans.}$$

Example 1.34. A non-inductive load takes 10 A at 100 V. Determine the inductance of a reactor to be connected in series in order that the same current be supplied from 220 V, 50 Hz mains. Determine the phase angle between the 220 V mains and the current neglect resistance of the reactance.

Solution: The resistance of the non-inductive load is $\frac{100}{10} = 10 \Omega$ and the impedance of

the reactor and the non-inductive load is $\frac{220}{10} = 22 \Omega$

$$\text{Hence reactance of coil} = \sqrt{22^2 - 10^2} = 19.6 \Omega$$

$$\text{Hence inductance} = \frac{19.6}{314} = 0.062 \text{ H} \quad \text{Ans.}$$

$$\text{and phase angle } \phi = \tan^{-1} \frac{X}{R} = \tan^{-1} \frac{19.6}{10} = 63^\circ \quad \text{Ans.}$$

Example 1.35. An iron cored coil of resistance 5Ω takes 10 A when connected to 200 V , 50 Hz supply and the power dissipated is 750 W . The coil is assumed to be equivalent to a series combination of R and L , determine (i) the iron loss (ii) the inductance at the given value of current and the (iii) p.f.

Solution: (i) Since the total power dissipated is 750 W and power dissipated in the resistance part of the coil is $10^2 \times 5 = 500 \text{ watts}$, hence iron loss is $750 - 500 = 250 \text{ watts}$. **Ans.**

$$(ii) \text{ The impedance of the coil } \frac{200}{10} = 20 \Omega$$

$$\text{Hence its reactance} = \sqrt{20^2 - 5^2} = 19.36 \Omega$$

$$\text{Hence its inductance } \frac{19.36}{314} = 0.0616 \text{ H}$$

$$\text{and p.f.} \quad \frac{750}{200 \times 10} = 0.375 \quad \text{Ans.}$$

Example 1.36. Determine the resonant frequency, the source current and the input impedance for the circuit shown in Fig. E1.36 for the following case:

$$R_L = 150 \Omega \quad R_C = 100 \Omega$$

The resonant frequency

$$f_0 = \frac{1}{2\pi \sqrt{LC}} \cdot \sqrt{\frac{R_L^2 - L/C}{R_C^2 - L/C}}$$

$$= \frac{1}{2\pi \sqrt{0.24 \times 3 \times 10^{-6}}} \cdot \sqrt{\frac{150^2 - \frac{0.24 \times 10^6}{3}}{100^2 - \frac{0.24 \times 10^6}{3}}}$$

$$= 170 \text{ Hz}$$

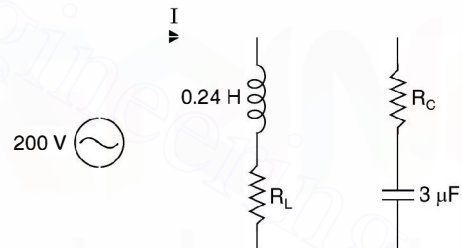

Fig. E1.36

Example 1.37. For the circuit shown in Fig. E1.37 determine (a) Q of the coil (b) Capacitance C (c) Q of the circuit (d) bandwidth of the circuit (e) maximum energy stored in the capacitor of the circuit (f) power dissipated in the resistor.

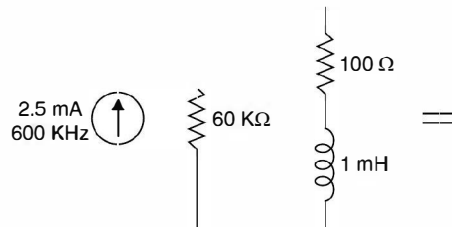

Fig. E1.37

Solution:

$$(a) \quad Q \text{ of the coil} = \frac{\omega_0 L}{R} = \frac{2\pi \times 600 \times 1000 \times 1 \times 10^{-3}}{100}$$

$$= 2\pi \times 6 = 6.28 \times 6 = 37.68$$

$$(b) \quad 600 \times 10^3 = \frac{1}{2\pi \sqrt{1 \times 10^{-3} C}}$$

$$C = \frac{10^{-3}}{4\pi^2 \times 36 \times 10^4}$$

$$= \frac{10^{-7}}{1419.78} = 70.43 \text{ pF}$$

(c) Q of the circuit

The equivalent resistance of coil and capacitor

$$= Q_c X_{c_0} = 37.68 \times \frac{10^{12}}{2\pi \times 600 \times 10^3 \times 70.43} = 3.78 \text{ k}\Omega$$

$$\text{The equivalent resistance} \frac{60 \times 3.78}{63.78} = 3.56 \text{ k}\Omega$$

$$\text{Therefore } Q \text{ of the circuit} = \omega_0 R_{e_q} C$$

$$= 2\pi \times 600 \times 10^3 \times 3.56 \times 10^3 \times 70.43 \times 10^{-12}$$

$$= 9.45 \quad \text{Ans.}$$

$$(d) \text{ Bandwidth of the circuit} = \frac{f_0}{Q} = \frac{600 \times 10^3}{9.45} = 63.5 \text{ KHz}$$

(e) The voltage across the capacitor at resonance

$$IR_{e_q} = 2.5 \times 10^{-3} \times 3.56 \times 10^3$$

$$= 8.75 \text{ volt}$$

Maximum energy stored by the capacitor

$$Cv^2 = 70.43 \times 10^{-12} \times 8.75^2$$

$$= 5392 \times 10^{-12} \text{ joule}$$

(f) Power dissipated in the resistor

$$= 2.5 \times 2.5 \times 3.56 \times 10^3$$

$$= 22.25 \text{ mW} \quad \text{Ans.}$$

Example 1.38. The circuit shown is connected across a voltage source of such that voltage across capacitor is $V_c = 20\sqrt{2} \sin 0.5t$. Determine the instantaneous energy stored in the capacitor and inductor (b) Q of the circuit.

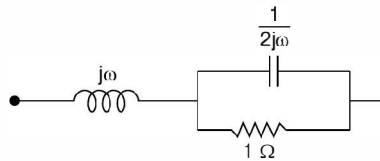

Fig. E1.38

Solution: The input impedance of the circuit is

$$j\omega + \frac{1 \times \frac{1}{2j\omega}}{1 + \frac{1}{2j\omega}} = j\omega + \frac{1}{1 + 2j\omega}$$

$$= j\omega + \frac{1}{1 + 4\omega^2} - j \frac{2\omega}{1 + 4\omega^2}$$

Putting the imaginary quantity to zero for resonance

$$\omega = \frac{2\omega}{1 + 4\omega^2}$$

or

$$\omega + 4\omega^3 = 2\omega$$

$$1 + 4\omega^2 = 2 \quad \text{or} \quad 4\omega^2 = 1$$

$$\omega = \frac{1}{2} = 0.5 \text{ rad/sec}$$

Taking capacitor voltage as reference

Since the voltage across capacitor is $20\sqrt{2} \sin 0.5t$ the current through capacitor is

$$C \frac{d}{dt} (20\sqrt{2} \sin 0.5t).$$

The current $I_c = \frac{20}{1/j2\omega_0} = j20 \text{ A}$

Current through resistor $= \frac{20}{1} = 20 \angle 0^\circ$

Therefore, current through the inductor

$$20 \angle 90^\circ + 20 \angle 0^\circ$$

$$= 20\sqrt{2} \angle 45^\circ$$

Hence the instantaneous current through the inductor = $20\sqrt{2}\sqrt{2}\sin(0.5t + 45^\circ)$

The instantaneous energy through the capacitor

$$\begin{aligned}\frac{1}{2}cv^2 &= \frac{1}{2} \times 2 (20\sqrt{2}\sin 0.5t)^2 \\ &= 800 \sin^2 0.5t\end{aligned}$$

Energy through the inductor

$$\begin{aligned}\frac{1}{2}Li^2 &= \frac{1}{2} \times 1 \times [40\sin(0.5t + 45^\circ)]^2 \\ &= 800 \sin^2(0.5t + 45^\circ)\end{aligned}$$

$$Q \text{ of the circuit} = \frac{2\pi \text{ Energy stored | max}}{\text{Energy dissipated}}$$

$$\text{loss in the resistor} = 400 \text{ watts}$$

$$\text{loss per cycle} = \frac{400}{f_0}$$

$$\text{Now } w_c(t) + w_L(t) = 800 \left[1 + \frac{\sin t - \cos t}{2} \right] = 800 \left[1 + \frac{\sqrt{2}}{2} \right]$$

$$\begin{aligned}\text{Therefore, } Q_0 &= \frac{0.5 \times 800}{400} \left[1 + \frac{1}{\sqrt{2}} \right] \\ &= 1 + \frac{1}{\sqrt{2}} = 1.707 \text{ Ans.}\end{aligned}$$

Example 1.39. Determine the current through all the branches of the given network.

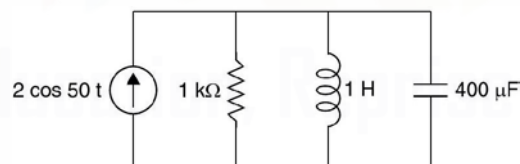

Fig. E1.39

Solution: The natural angular frequency

$$= \frac{1}{\sqrt{1 \times 400 \times 10^{-6}}} = \frac{1000}{20}$$

$$= 50 \text{ rad/sec}$$

Therefore, current source at $\omega = 50$ rad/sec produces resonance in the circuit.

The current i supplied by the source is 2 A peak

The voltage across the source is

$$iR = 2 \times 1000 = 2000 \text{ volts}$$

$$v(t) = 2000 \sin 50 t$$

The current through the inductor

$$\begin{aligned} \frac{2000}{j \times 50 \times 1} &= -j 40 \\ &= 40 \cos (50t - 90^\circ) = 40 \sin 50t \end{aligned}$$

Current through capacitor

$$\begin{aligned} i_c(t) &= \frac{v(t)}{1/j\omega_0 C} \\ &= j 2000 \times 50 \times 10^{-6} \times 400 \\ &= j 40 \text{ A} = 40 \cos (50t + 90^\circ) \\ &= -40 \sin 50t \quad \text{Ans.} \end{aligned}$$

Example 1.40. Fig. 1.40 represents the magnetic circuit of an attracted armature relay. The coil has 500 turns and the mean core length is 400 mm when the air gap lengths are 1.0 mm each a flux density of 0.8 Tesla is required to actuate the relay. The magnetic field intensity is 500 AT/m for the material at the given flux density. Determine (i) the current required to operate the relay (ii) the permeability and μ_r of the core and (iii) the current required if the gap is zero.

Solution. Since the air gap is small flux fringing can be neglected. Hence the flux density is same in both the core the air gap.

The mmf required for the core is $500 \times 0.4 = 200 \text{ AT}$

$$\begin{aligned} \text{mmf for the air gap} &= 2 \times 1 \times 10^{-3} \times \frac{0.8}{4\pi \times 10^{-7}} \\ &= 2 \times 10^4 \times \frac{0.8}{4\pi} = 1273 \text{ AT} \end{aligned}$$

Hence total mmf required = $1273 + 200 = 1473 \text{ AT}$

(i) Since the number of turns is 500, the current required to operate the relay is

$$\frac{1473}{500} = 2.95 \text{ A}$$

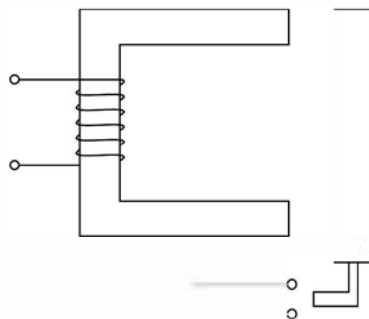

Fig. E1.40

It is to be noted that even though the air gap is only 2mm whereas the length of the magnetic path is 400 mm, most of the mmf required is to overcome the air gap reluctance

$$(ii) \quad \mu = \frac{B}{H} = \frac{0.8}{500} = 1.6 \times 10^{-3}$$

$$\mu_r = \frac{\mu}{\mu_0} = \frac{1.6 \times 10^{-3}}{4\pi \times 10^{-7}} = 1273$$

(iii) If the gap is zero, total mmf required is 200 AT. Hence the current required $\frac{200}{500} = 0.4$ A.

Example 1.41. A toroid is composed of three ferromagnetic materials, nickel-iron alloy, silicon steel and cast steel each having mean arc lengths 0.3 m, 0.2 m and 0.1 m respectively (Total length of toroid 0.6 m) Area of cross-section of Toroid is $1 \times 10^{-3} \text{ m}^2$. The toroid has a coil of 100 turns. Determine (i) the mmf required to establish a magnetic flux of $\phi = 6 \times 10^{-4} \text{ Wb}$ (ii) the current through the coil (iii) the relative permeability – and reluctance of each ferromagnetic material. Assume the magnetic field intensities for $B = 0.6$ Tesla for the three materials as 10 AT/m, 77 AT/m and 270 AT/m respectively.

Solution. Since magnetic field intensities in the three materials are known, the total mmf required

$$(i) \quad 10 \times 0.3 + 77 \times 0.2 + 270 \times 0.1 = 45.4 \text{ AT}$$

$$\text{The magnetic flux density } B = \frac{\phi}{A} = \frac{6 \times 10^{-4}}{10^{-3}} = 0.6 \text{ Tesla}$$

$$(ii) \quad \text{The current required } \frac{45.4}{100} = 0.454 \text{ A}$$

(iii) Relative permeability of nickel iron.

$$\text{Since} \quad \mu = \frac{B}{H} = \frac{0.6}{10} = 0.06 \text{ H/m}$$

$$\text{Therefore} \quad \mu_r = \frac{\mu}{4\pi \times 10^{-7}} = \frac{6 \times 10^{-2}}{4\pi \times 10^{-7}} = 47750. \quad \text{Ans.}$$

$$\text{Now reluctance} = \frac{\text{mmf}}{\text{flux}} = \frac{3}{6 \times 10^{-4}} = 5000. \quad \text{Ans.}$$

Following the same procedure the μ_r and reluctance of the other two materials respectively are

$$\begin{array}{ll} \mu_r = 6210 & \text{Reluctance } 25670 \\ \mu_r = 1768 & \text{Reluctance } 45000. \quad \text{Ans.} \end{array}$$

The equivalent electrical analog is

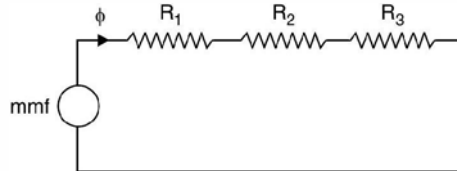

Fig. E1.41a

Example 1.42. For the toroid of the previous example, determine the magnetic flux approximately produced if the mmf applied is 35 AT.

Solution. It is slightly difficult to obtain exact value of flux as for that we need to know reluctance of each part of the magnetic corresponding to a new value of flux density which is possible if we know flux ϕ right at the start. However, assuming that the reluctance does not change materially corresponding to new B or H , hence

$$\phi = \frac{\text{mmf}}{\text{reluctance}} = \frac{35}{47750 + 25670 + 45000} = 0.0003 \text{ Wb. Ans.}$$

Example 1.43. Determine the (i) mmf (ii) magnetic flux (iii) reluctance and (iv) flux density for the following case : A steel ring 30 cm mean diameter and of circular section 2 cms in diameter has an air gap 1 mm long : it is wound uniformly with 600 turns of wire carrying a current of 2.5 A. Neglect magnetic leakage. The iron path takes about 40% of the total mmf.

Solution. The mmf is $600 \times 2.5 = 1500$ AT. The mmf required for air gap is

$$1500 \times 0.6 = 900 \text{ AT}$$

$$\begin{aligned} \text{Reluctance of air gap} &= \frac{l}{\mu_0 A} = \frac{1 \times 10^{-3}}{4\pi \times 10^{-7} \times \pi \times 10^{-4}} \\ &= \frac{10^8}{4\pi^2} = \frac{100 \times 10^6}{4\pi^2} = 2.535 \times 10^6 \end{aligned}$$

$$\begin{aligned} \text{Hence flux through the gap} &= \frac{400 \times 10^{-6}}{2.53} \\ &= \frac{9 \times 10^{-4}}{2.53} = 0.355 \text{ mWb} \end{aligned}$$

Since flux through the air gap and steel is same therefore reluctance of the steel

$$\frac{600 \times 10^3}{0.355} = \frac{6}{0.353} \times 10^5 = 1.69 \times 10^6$$

$$\text{Hence total reluctance} = (2.535 + 1.69) \times 10^6 = 4.22 \times 10^6$$

$$\text{Flux density } B = \frac{\phi}{A} = \frac{0.355 \times 10^{-3}}{\pi \times 10^{-4}} = \frac{3.55}{\pi} = 1.13 \text{ Wb/m}^2. \text{ Ans.}$$

A given network will always have a unique solution in terms of its nodal voltages and loop currents. It is, therefore, required to write down a set of linearly independent simultaneous equations equal to the number of unknowns, and smaller the number of unknowns fewer the linear simultaneous equations and less time consuming will be the solution of these equations. It would be seen that sometimes it is more convenient to use nodal voltages as independent variables, sometimes loop currents as independent variables and yet sometimes a suitable combination of both from the point of view of minimum independent variables required to describe the network and hence the number of equations to seek solution of the network.

If 'n' is the number of nodes and 'b' the number of branches in a given network, the minimum number of independent nodal voltages (nodal analysis) minimum number of independent loop currents (loop analysis) to describe the network uniquely is given by $(n - 1)$ or $(b - n + 1)$ respectively. Therefore, from solution point of view, whichever is smaller of the two should be used for analysis of a given network. However, it may be mentioned here that there could be situations when it could be mandatory to use only a particular kind of variables (viz. nodal voltages) as we may not be interested in the other kind of variables (viz. loop currents).

PROBLEMS

- 1.1. Determine the average value of the waveform shown

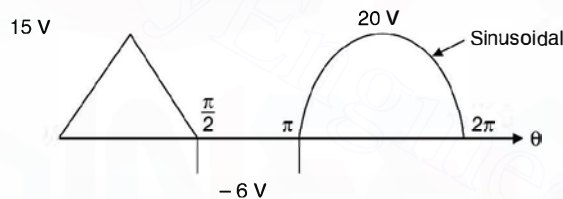

Fig. P1.1

[Ans. 6.74]

- 1.2. Determine the effective value for the waveform shown

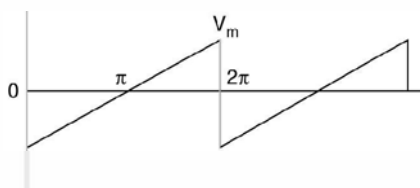

Fig. P1.2

[Ans. $V_m / \sqrt{3}$]

- 1.3. The power in a 20 ohm load is 10 W. What is the peak to peak sinusoidal voltage across the load.

[Ans. 40 V]

- 1.4. A resistor and a capacitor in series are connected to a 120 V, 60 Hz supply. The impedance of the circuit is 86 ohms and the power consumed is also 86 W. Determine the value of R and C .
[Ans. 44.17 Ω , 35.9 μF]
- 1.5. A 200 ohm resistor is in series with a capacitor across 240 V, 60 Hz. Supply. The power is 100 W. Determine C and I .
[Ans. 9.67 μF , 0.707 A]
- 1.6. The resistance of a coil is 140 Ω and its inductance 0.85 H. Determine the current, the p.f. and the circuit impedance when the coil is connected to 120 V, 60 Hz supply.
[Ans. 0.344 $\angle -66.4$, 0.4, 349 $\angle 66.4$]
- 1.7. A 240 V, 50 KVA generator operates at a leading p.f. of 0.8. Determine the equivalent series impedance of the load.
[Ans. 0.922 – $j0.691$]
- 1.8. A 0.1 H inductor is in series with a 5 Ω resistor. The series combination is placed across a 120 V, 60 Hz supply. Determine the current in rectangular and polar coordinates.
[Ans. 0.415 – $j3.128$ A]
- 1.9. Two appliances are operated in parallel from a 120 V supply. One draws 12 A at a lagging p.f. of 0.8 and the other draws 8A at 0.75 p.f. lead. Determine the total current and the power.
[Ans. 15.6 – $j1.91$ A, 1872 W]
- 1.10. Two branches connected in parallel have impedances of 120 + $j180 \Omega$ and 150 – $j130 \Omega$ respectively. Determine the branch currents, the line current and the power delivered to the circuit if it is connected across 115 V supply.
[Ans. 0.53 $\angle -56.3$, 0.58 $\angle 40.9$, 0.732 A, 84.2 W]
- 1.11. Two circuits, the impedances of which are given by $Z_1 = 10 + j15 \Omega$ and $Z_2 = 6 - j8 \Omega$ are connected in parallel. If the total current supplied is 15 A, what is the power taken by each branch?
[Ans. 737 W, 1430 W]
- 1.12. Discuss various characteristics of a series RLC resonant circuit. Derive mathematical expressions in support of your discussion.
- 1.13. Define Q of a coil and Q of a series RLC circuit. Show that the voltage across the inductor or capacitor in a series RLC circuit is Q times the supply voltage at resonance.
- 1.14. What are half-power frequencies in a series RLC resonance circuit? Derive an expression for bandwidth of the circuit.
- 1.15. Discuss various characteristics of a general parallel RLC circuit at resonance. Derive resonance frequency when (a) coil is loss free (b) capacitor is loss free (c) both are loss free. Draw the equivalent circuit when Q of the circuit is high.
- 1.16. Derive an expression for Q of a parallel resonance circuit from first principles. A given parallel circuit has certain bandwidth. If it is required to obtain a lower bandwidth what measure should be taken to achieve this?
- 1.17. Explain what you mean by selectivity of a circuit and explain how it can be improved.
- 1.18. A 70 ohm resistor, a 5 mH coil and a 15 pF capacitor are in series across a 110 volt supply. Determine the resonant frequency the Q of the circuit at this frequency, the voltage across the capacitor at resonance.
[Ans. 581 kHz, 261, 28.71 kV]
- 1.19. A variable inductor is connected in series with a resistor and a capacitor. The circuit is connected to a 200 volt 50 Hz supply and the maximum current obtainable by varying inductance is 0.314 A. The voltage across the capacitor then is 300 V. Determine the circuit constants.
[Ans. 3.3 μF , 637 Ω , 3.04 H]
- 1.20. A coil of 20 Ω resistance and 0.2 H inductance is connected in parallel with a capacitor of 100 μF capacitance. Find the frequency of resonance and the effective impedance at resonance.
[Ans. 31.8 Hz, 100 Ω]

- 1.21. A series circuit consists of a 115Ω resistor, a $0.024 \mu\text{F}$ capacitor and coil of inductance L . If the resonant frequency of the circuit is 1000 Hz determine L and the bandwidth.
[Ans. 1.055 H , 17.3 Hz]
- 1.22. Three coils are interconnected with winding sense shown by dots. The self inductance of the coils are 2 H each and the mutual inductance 1 H each. Determine L_{eq} between $11'$.

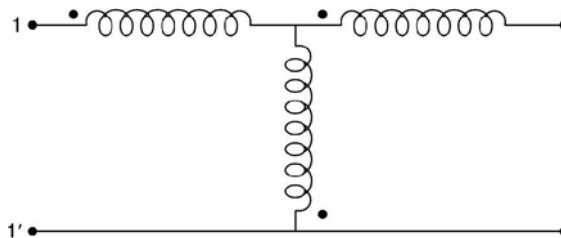

Fig. P1.22

- 1.23. Two coils are wound on the same core and have negligible resistance as shown in the Fig. 1.23. Determine the current in the 1000 ohm resistor and its phase angle with respect to the applied voltage of 100 volt at a frequency of $\frac{5000}{2\pi} \text{ Hz}$ when the coils act (i) in the same sense (ii) in opposite sense.

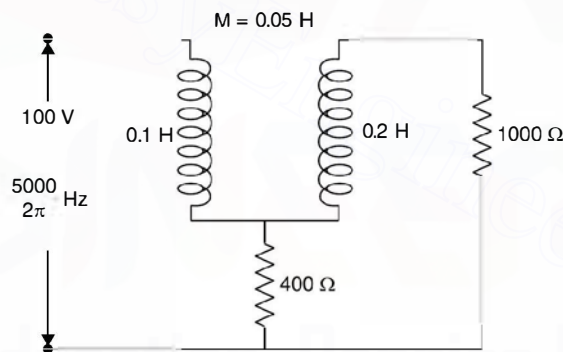

Fig. P1.23

- 1.24. A cast steel ring has a circular cross sections 3 cm in diameter and a mean circumference of 80 cm . The ring is uniformly wound with a coil of 600 turns. (a) Estimate the current required to produce a flux of 0.5 mWb in the ring (b) if a saw cut 2 mm wide is made in the ring, find approximately the flux produced by the current found in (a). (c) Find the current which will give the same flux as in (a). Assume $H = 650 \text{ AT/m}$ for $B = 0.707 \text{ wb/m}^2$.
- 1.25. A ring of cast steel has an external diameter of 24 cms and a square section of 3 cm side. Inside and across the ring an ordinary steel bar $18 \times 3 \times 0.4 \text{ cm}$ is fitted with negligible gap. Calculate the number of ampere turns to be applied to one half of the ring to produce a flux density of 1 wb/m^2 in the other half.
- 1.26. An iron ring with a mean circumference of 140 cm and cross section 12 cm^2 is wound with 500 turns of wire. When the exciting current is 2 A , the flux is found to be 1.2 mwb . Determine relative permeability of iron.

- 1.27. An iron magnetic circuit has a uniform cross sectional area of 5 cm^2 and a length of 25 cm. A coil of 120 turns is wound uniformly over the magnetic circuit. When the current in the coil is 1.5 A, the total flux is 0.3 mwb and when the current is 5 A, the total flux is 0.6 mwb. For each value of current calculate H and μ_r .
- 1.28. Define the following terms. Magnetic flux density, magnetic field intensity, mmf, reluctance.
- 1.29. Discuss briefly analogies between magnetic and electric circuits.
- 1.30. A two limb magnetic circuit has magnetic path of 30 cms and an air gap of 5 mm. The area of cross section of magnetic path is 9 cm^2 . The relative permeability of core is 5000 and the circuit has 500 turns wound on one limb. The magnetic flux density required is 1 Wb/m^2 . Determine (i) the current (ii) Flux ϕ and flux linkage. [Ans. (i) 0.89 A (ii) $9 \times 10^{-4} \text{ Wb}$, 0.45 Wb turns]
- 1.31. The total flux in the gap of a permanent magnet is 0.0075 Wb. The diameter of the circular pole faces are 12.7 cm and the length of the air gap is 4.57 cm. Determine the values of B and H in the gap. Assume that there is no fringing. [Ans. 0.592 T , $4.7 \times 10^5 \text{ A/m}$]
- 1.32. A long wire of radius R carries dc current I ampere uniformly distributed over the cross section. Determine magnetic field intensity for all distances $r \leq R$ and $r > R$.
 [Ans. $H = \frac{Ir}{2\pi R^2}$, $H = \frac{I}{2\pi r}$]
- 1.33. A long horizontal wire carrying 20 A is placed crosswise to the earth's magnetic field . At what point does the magnetic field of the wire just cancel terrestrial magnetism ? The earth's magnetic field acts downwards at an angle of 30° from the vertical with a magnetic flux density of $60 \mu\text{T}$. [Ans. 0.067m]
- 1.34. Fig. Q1.34 shows the magnetic circuit. The central limb has a cross section of 800 mm^2 and each of the outer limb has a cross section of 500 mm^2 .

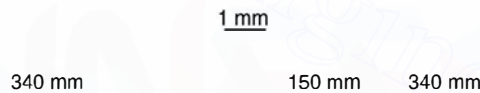

Fig. Q1.34

Determine the mmf required to produce a flux of 1 mWb in the central limb. Neglect leakage and assume H for $B = 1.25 \text{ Wb/m}^2$ as 825 AT/m and for $B = 1 \text{ Wb/m}^2$ assume $H = 350 \text{ AT/m}$.

[Ans. 1238 AT]

CHAPTER

2

Network Theory

2.1 INTRODUCTION

Kirchhoff's postulated two basic laws way back in 1845 which are used for writing network equations. These laws concern the algebraic sum of voltages around a loop and currents entering or leaving a node. The word algebraic is used to indicate that summation is carried out taking into account the polarities of voltages and direction of currents. While traversing a loop we will take voltage drops as positive and voltage rises as negative. Also while considering currents at a node, the currents entering the node will be taken as positive and those leaving would be taken as negative.

2.2 KIRCHHOFF'S LAWS

Kirchhoff's voltage law usually abbreviated as KVL is stated as follows :

The algebraic sum of all branch voltage around any closed loop of a network is zero at all instants of time. Alternatively, Kirchhoff's voltage law can be stated in terms of voltage drops and rises as follows: The sum of voltage rises and drops in a closed loop at any instant of time are equal. KVL is a consequence of law of conservation of energy as voltage is energy or work per unit charge. If we start from one node in a loop and move along the closed loop and come back to the same node, obviously the total potential difference or sum of potential rises must equal the total sum of potential falls. Just as, if we start from one point on the surface of the earth and after travelling through valleys and hills come back to the same point, the total displacement is zero. We talk elevation's and depression on the earth with respect to the sea level. Similarly, in case of voltages we take ground as the reference which is shown in Fig. 2.1(a). Here potential of node *A* is above the ground and that of *B* is below the ground potential.

We know that electronic current flows from negative potential to positive potential, the conventional current flows from positive potential to negative potential. Therefore, when current *i* flows in the circuit of Fig. 2.1(b) it produces voltages polarities in various elements as shown in the Fig. Applying Kirchhoff's voltage law

$$v_1 + v_2 + v_3 - v = 0$$

Or in terms of voltage drops and voltage rises

$$v_1 + v_2 + v_3 = v \quad \dots(2.1)$$

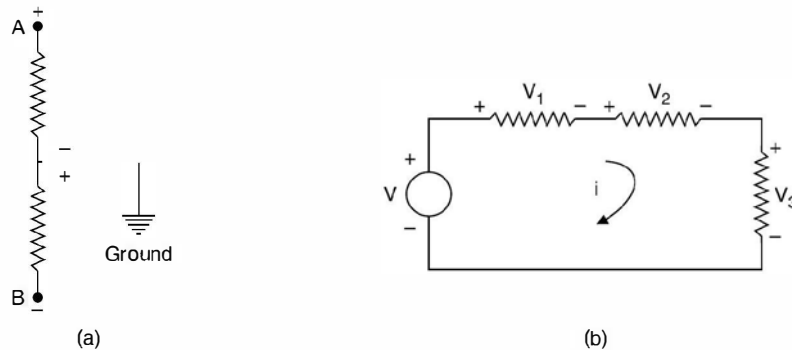

Fig. 2.1 (a) Potential reference, (b) KVL application.

Kirchhoff's current law states that the algebraic sum of all currents terminating at a node equals zero at any instant of time. Alternatively, this states that sum of all currents entering a node equals the sum of currents leaving the same node at any instant of time.

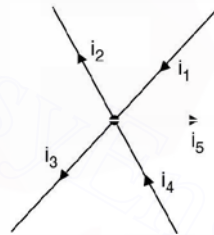

Fig. 2.2 One node with terminating branches.

Fig. 2.2 shows one node along with various branches terminating in it, in a network and the currents with directions in the various branches are shown by the arrows. Applying Kirchhoff's current law abbreviated by KCL we get

$$i_1 + i_4 - i_2 - i_3 - i_5 = 0$$

or

$$i_1 + i_4 = i_2 + i_3 + i_5 \quad \dots(2.2)$$

KCL is a consequence of law of conservation of charge. The charge that enters a node, must leave that node as it can't be stored there. Since the algebraic sum of charges at a node must be zero, its time derivative must also be zero at any instant of time.

The two basic laws by Kirchhoff's can be applied to solve any network irrespective of its complexity. One typical application could be to find out equivalence between two networks or given a network in some configurations, how to find its equivalent so that it could be used more conveniently.

By definition, two networks are said to be equivalent at a pair of terminals if the voltage current relationships for the two networks are identical at these terminals. Consider a network having two resistances in series as shown. The objective is to replace it by a single equivalent resistance

From Fig. 2.3(a), we have

$$v = v_1 + v_2 = ir_1 + ir_2 \quad \dots(2.3)$$

and from Fig. 2.3(b) we have

$$v = ir$$

Therefore,

$$r = r_1 + r_2$$

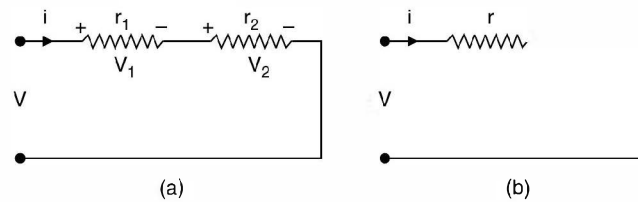

Fig. 2.3 (a) Series connection of resistances, (b) Equivalent of (a).

Similarly if there are n number of resistances in series, the equivalent single resistance would be

$$r = r_1 + r_2 + \dots + r_n \quad \dots(2.4)$$

Similarly if the elements are inductances and v_1, v_2 are the drops across L_1, L_2 respectively, and i is the current then applying Kirchhoff's voltage law we have

$$\begin{aligned} v &= v_1 + v_2 = L_1 \frac{di}{dt} + L_2 \frac{di}{dt} \\ &= (L_1 + L_2) \frac{di}{dt} = L \frac{di}{dt} \end{aligned}$$

Therefore,

$$L = L_1 + L_2$$

If there are n inductors in series it can be shown that single equivalent inductor

$$L = L_1 + L_2 + \dots + L_n \quad \dots(2.5)$$

If two capacitors are connected in series then

$$\begin{aligned} v &= v_1 + v_2 = \frac{1}{C_1} \int i dt + \frac{1}{C_2} \int i dt \\ &= \left(\frac{1}{C_1} + \frac{1}{C_2} \right) \int i dt = \frac{1}{C} \int i dt \end{aligned}$$

Therefore,

$$\frac{1}{C} = \frac{1}{C_1} + \frac{1}{C_2} \quad \dots(2.6)$$

Similarly by using KCL, law of parallel combination of these elements can be obtained. We will try here for inductors. Say there are two inductors connected in parallel.

From Fig. 2.4(a)

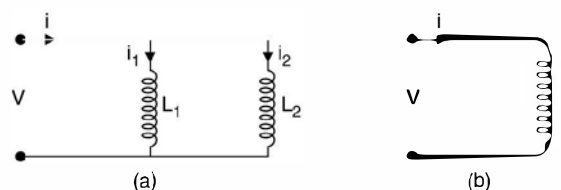

Fig. 2.4 (a) Inductor in parallel (b) Equivalent of (a).

$$i = i_1 + i_2 = \frac{1}{L_1} \int v dt + \frac{1}{L_2} \int v dt = \left(\frac{1}{L_1} + \frac{1}{L_2} \right) \int v dt$$

$$= \frac{1}{L} \int v dt$$

Therefore, $\frac{1}{L} = \frac{1}{L_1} + \frac{1}{L_2}$... (2.7)

Similarly it can be proved that if there are n resistors connected in parallel its single equivalent resistance is given by

$$\frac{1}{r} = \frac{1}{r_1} + \frac{1}{r_2} + \dots + \frac{1}{r_n}$$
 ... (2.8)

and if n number of capacitors are connected in parallel, then single equivalent capacitance is given as

$$C = C_1 + C_2 + \dots + C_n$$
 ... (2.9)

2.3 STAR-DELTA TRANSFORMATION

By using the same definition of equivalence of two networks i.e. the two networks are equivalent between two terminals if the v - i relations are same i.e. the impedances as seen between the two terminals are same.

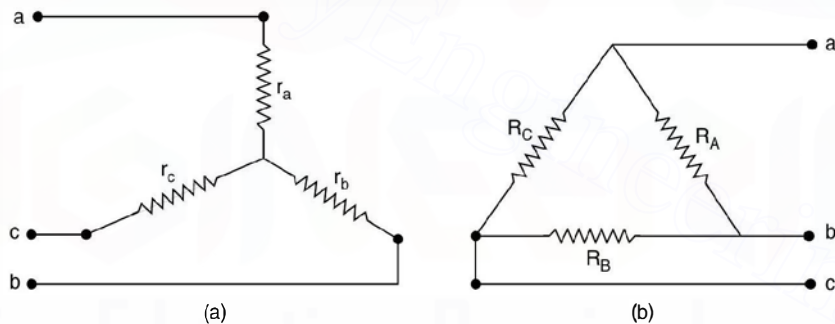

Fig. 2.5 (a) Star, (b) Delta.

Suppose we are given star connected elements as shown in Fig. 2.5(a) and we have to find its equivalent delta connected elements then we should equal the equivalent resistance between the same two terminals.

Between a and b

$$\frac{R_A(R_B + R_C)}{R_A + R_B + R_C} = r_a + r_b$$
 ... (2.10)

Between b and c

$$\frac{R_B(R_A + R_C)}{R_A + R_B + R_C} = r_b + r_c$$
 ... (2.11)

Between c and a

$$\frac{R_C(R_A + R_B)}{R_A + R_B + R_C} = r_c + r_a \quad \dots(2.12)$$

Similarly shorting bc and measuring resistance between a and bc , we have

$$\frac{R_A R_C}{R_A + R_C} = r_a + \frac{r_b r_c}{r_b + r_c} \quad \dots(2.13)$$

Shorting ca and resistance between b and ca

$$\frac{R_A R_B}{R_A + R_B} = r_b + \frac{r_c r_a}{r_c + r_a} \quad \dots(2.14)$$

Shorting ab and resistance between c and ab

$$\frac{R_B R_C}{R_B + R_C} = r_c + \frac{r_a r_b}{r_a + r_b} \quad \dots(2.15)$$

Subtracting equation (2.13) from (2.10) we have

$$r_b - \frac{r_b r_c}{r_b + r_c} = \frac{R_A(R_B + R_C)}{R_A + R_B + R_C} - \frac{R_A R_C}{R_A + R_C}$$

$$\frac{r_b^2}{r_b + r_c} = \frac{R_A^2 R_B}{(R_A + R_C)(R_A + R_B + R_C)}$$

Substituting for $(r_b + r_c)$ from equation (2.11)

$$\frac{r_b^2(R_A + R_B + R_C)}{R_B(R_A + R_C)} = \frac{R_A^2 R_B}{(R_A + R_C)(R_A + R_B + R_C)}$$

or

$$r_b^2 = \frac{R_A^2 R_B^2}{(R_A + R_B + R_C)^2}$$

or

$$r_b = \frac{R_A R_B}{R_A + R_B + R_C} \quad \dots(2.16)$$

r_a and r_c can be obtained using equation (2.10) and (2.11) along with the expression for r_b and it can be seen that

$$r_a = \frac{R_A R_C}{R_A + R_B + R_C} \quad \dots(2.17)$$

and

$$r_c = \frac{R_B R_C}{R_A + R_B + R_C} \quad \dots(2.18)$$

To transform a given star into delta following steps are used.

From equation (2.13) we have

$$\frac{R_A R_C}{R_A + R_C} = \frac{r_a r_b + r_b r_c + r_c r_a}{r_b + r_c}$$

using equations (2.11) and (2.16) we have

$$r_a r_b + r_b r_c + r_c r_a = R_c r_b$$

Therefore,
$$R_C = \frac{r_a r_b + r_b r_c + r_c r_a}{r_b} \quad \dots(2.19)$$

Similarly,
$$R_B = \frac{r_a r_b + r_b r_c + r_c r_a}{r_a} \quad \dots(2.20)$$

$$R_A = \frac{r_a r_b + r_b r_c + r_c r_a}{r_c} \quad \dots(2.21)$$

An easier way to remember these formulae is as follows. Suppose we want to transform star into delta. The numerator is same for all the three branches and is equal to the product of impedance taken two at a time i.e. $Z_a Z_b + Z_b Z_c + Z_c Z_a$ and in the denominator it will be the star branch opposite to the equivalent delta branch i.e. if Z_A is required the denominator will have impedance Z_c . Similarly for Z_B it will be Z_a and for Z_C it will be Z_b Fig. 2.6.

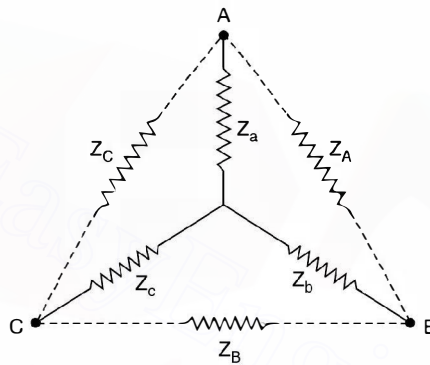

Fig. 2.6

Again for transforming delta into star consider the Fig. 2.7.

To find Z_a open the delta vertex at A. The two impedances associated at vertex A are Z_A and Z_C . The equivalent star.

$$Z_a = \frac{Z_A Z_C}{Z_A + Z_B + Z_C}$$

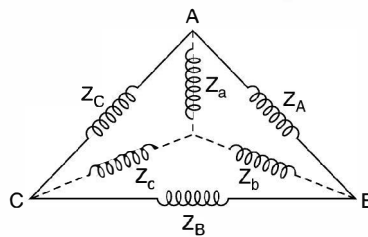

Fig. 2.7 Delta to star transformation.

Here denominator is same for all the three legs of the equivalent star.

2.4 LOOP ANALYSIS

Let us consider a few application of KVL in terms of loop or mesh analysis.

Example 2.1. Determine the current in all the branches of the network using loop analysis.

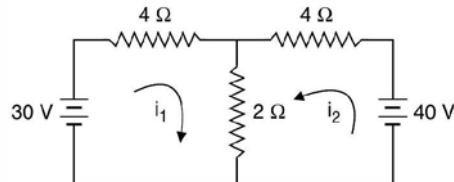

Fig. E2.1

Solution: Let the currents i_1 and i_2 be flowing in the two loops as shown. It is to be noted that the direction of the currents is arbitrary. However, depending upon the values of i_1 and i_2 thus obtained we can ascertain the direction. If they are coming out to be positive, the directions remain as shown in the figure, otherwise one with negative value, the direction of this current is reversed.

Writing loop equation for loop 1

$$4i_1 + 2(i_1 + i_2) = 30$$

$$\text{or } 6i_1 + 2i_2 = 30 \quad \dots(1)$$

$$\text{Loop 2 } 4i_2 + 2(i_1 + i_2) = 40$$

$$\text{or } 2i_1 + 6i_2 = 40 \quad \dots(2)$$

Multiplying equation (2) by 3 and subtracting equation (1) from this we have

$$16i_2 = 90 \quad \text{or } i_2 = 5.625 \text{ A}$$

$$\text{Hence } 2i_1 + 6 \times 5.625 = 40$$

$$2i_1 = 40 - 33.75$$

$$\text{or } 2i_1 = 6.25, i_1 = 3.125 \text{ A } \quad \text{Ans.}$$

$$\text{Hence } i_3 = i_1 + i_2 = 5.625 + 3.125 = 8.75 \text{ A}$$

The current through 2Ω branch is 8.75 A .

Since both the currents i_1 and i_2 are found to be positive hence the directions shown in Fig. E2.1 is correct.

Suppose we take the direction of current for i_2 as shown in Fig. E2.1.1 shown here

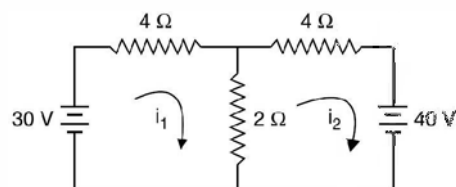

Fig. E2.1.1

For loop 1

$$4i_1 + 2(i_1 - i_2) = 30$$

or $6i_1 - 2i_2 = 30$... (1)

$$4i_2 + 2(i_2 - i_1) + 40 = 0$$

or $-2i_1 + 6i_2 = -40$... (2)

Multiply equation (2) by 3 and add to equation (1)

$$16i_2 = -120 + 30 = -90$$

$$i_2 = -5.625$$

and $-2i_1 - 33.75 = -40$

or $-2i_1 = -6.25$

or $i_1 = 3.125 \text{ A}$

We find the i_2 is coming out to be negative and hence the direction of current in loop 2 should be opposite to what is shown in Fig. E2.1.1.

Example 2.2. Determine the current in each branch of the network shown in Fig. E2.2 using loop analysis.

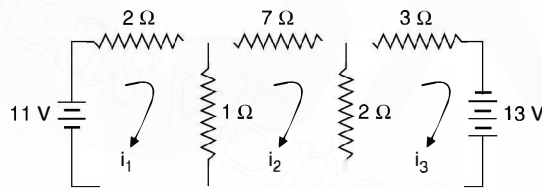

Fig. E2.2

Solution: Since there are three loops, three independent loop equations are required to solve the network. Suppose the directions of currents are as shown in Fig. E2.2. Writing equations for the three loops

Loop I $2i_1 + 1(i_1 - i_2) = 11$

$$3i_1 - i_2 = 11$$
 ... (1)

Loop II $7i_2 + 2(i_2 - i_3) + (i_2 - i_1)1 = 0$

or $-i_1 + 10i_2 - 2i_3 = 0$... (2)

Loop III $3i_3 + 2(i_3 - i_2) = 13$

$$-2i_2 + 5i_3 = 13$$
 ... (3)

In matrix form the equations can be written as

$$\begin{bmatrix} 3 & -1 & 0 \\ -1 & 10 & -2 \\ 0 & -2 & 5 \end{bmatrix} \begin{bmatrix} i_1 \\ i_2 \\ i_3 \end{bmatrix} = \begin{bmatrix} 11 \\ 0 \\ 13 \end{bmatrix}$$

Hence $\det [A] = \begin{vmatrix} 3 & -1 & 0 \\ -1 & 10 & -2 \\ 0 & -2 & 5 \end{vmatrix}$

$$= 3(50 - 4) + 1(-5) = 133$$

$$i_1 = \frac{\begin{vmatrix} 11 & -1 & 0 \\ 0 & 10 & -2 \\ 13 & -2 & 5 \end{vmatrix}}{133} = 11(50 - 4) + 26 = 11 \times 46 + 26$$

$$= \frac{532}{133} = 4\text{A}$$

$$i_1 = 4\text{A}$$

From equation 1

$$3 \times 4 - i_2 = 11$$

or

$$-i_2 = -1$$

or

$$i_2 = 1\text{A}$$

and from equation (3)

$$-2 + 5i_3 = 13 \text{ or } 5i_3 = 15$$

or

$$i_3 = 3\text{ A } \text{ Ans.}$$

Example 2.3. Determine the currents i_1 , i_2 and i_3 and the Voltage V_1 and V_2 in the given network.

Using KVL we have

$$0.2 i_1 + (i_1 - i_2) 3.75 = 120 \quad \text{Loop I}$$

$$3.75 (i_2 - i_1) + 0.3 i_2 + 5.45 (i_2 - i_3) = 0 \quad \text{Loop II}$$

$$5.45 (i_3 - i_2) + 0.1 i_3 = 110 \quad \text{Loop III}$$

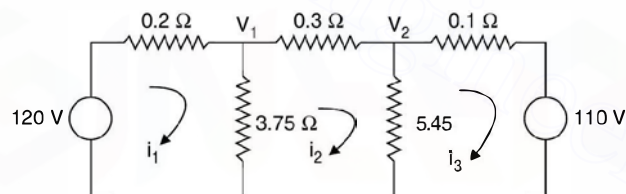

Fig. E2.3

Rearranging the equations, we have

$$(0.2 + 3.75) i_1 - 3.75 i_2 = 120$$

$$-3.75 i_1 + (3.75 + 0.3 + 5.45) i_2 - 5.45 i_3 = 0$$

$$-5.45 i_2 + (5.45 + 0.1) i_3 = 110$$

These equations can be written in matrix form as follows

$$\begin{bmatrix} (0.2 + 3.75) & -3.75 & 0.0 \\ -3.75 & (3.75 + 0.3 + 5.45) & -5.45 \\ 0.0 & -5.45 & 5.45 + 0.1 \end{bmatrix} \begin{bmatrix} i_1 \\ i_2 \\ i_3 \end{bmatrix} = \begin{bmatrix} 120 \\ 0.0 \\ 110 \end{bmatrix}$$

or

$$ZI = V$$

Here Z matrix is the loop impedance matrix and is found to be a symmetric matrix along its leading diagonal.

It can be seen that the loop impedance matrix can be written by inspection of the loops.

- (i) The diagonal elements are the sum of all the branch impedances in the corresponding loop.
- (ii) The off-diagonal elements say Z_{12} is the impedance of the branches common to both the loop 1 and 2. The sign is positive if current i_1 and i_2 in the common branch flow in the same direction and is taken as negative if the two currents oppose each other.

The above set of these equations can again be written in matrix form as follows:

$$\begin{bmatrix} 3.95 & -3.75 & 0.0 \\ -3.75 & 9.50 & -5.45 \\ 0.0 & -5.45 & 5.55 \end{bmatrix} \begin{bmatrix} i_1 \\ i_2 \\ i_3 \end{bmatrix} = \begin{bmatrix} 120 \\ 0.0 \\ 110 \end{bmatrix}$$

Using Cramer's rule

$$i_1 = \frac{\begin{vmatrix} 120 & -3.75 & 0.0 \\ 0.0 & 9.50 & -5.45 \\ 110 & -5.45 & 5.55 \end{vmatrix}}{\begin{vmatrix} 3.95 & -3.75 & 0.0 \\ -3.75 & 9.50 & -5.45 \\ 0.0 & -5.45 & 5.55 \end{vmatrix}} = \Delta$$

Similarly

$$i_2 = \frac{\begin{vmatrix} 3.95 & 120 & 0.0 \\ -3.75 & 0.0 & -5.45 \\ 0.0 & 110 & 5.55 \end{vmatrix}}{\Delta}$$

Similarly expression for i_3 can be written. On solution the approximate values of i_1 , i_2 and i_3 are found to be 40 A, 10 A and -10 A. Here -10 A in the third loop means the direction of current in the third loop should be opposite to what has been assumed at the beginning of the solution.

The voltage $v_1 = (i_1 - i_2) 3.75$
 $= 30 \times 3.75$
 $= 112.5$ Volts

and $V_2 = 20 \times 5.45 = 109$ volts

Example 2.4. Determine the current in the battery, the current in each branch and the p.d. across AB in the network shown.

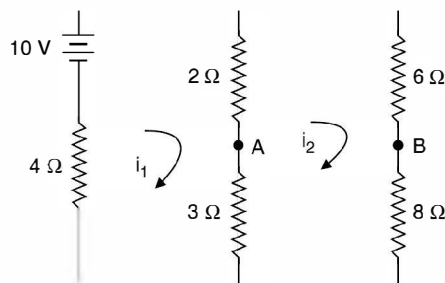

Fig. E2.4

Using KVL we have the equations in the matrix form.

$$\begin{bmatrix} 9 & -5 \\ -5 & 19 \end{bmatrix} \begin{bmatrix} i_1 \\ i_2 \end{bmatrix} = \begin{bmatrix} 10 \\ 0 \end{bmatrix}$$

From second equation

$$-5 i_1 + 19 i_2 = 0$$

or
$$i_1 = \frac{19}{5} i_2$$

From first equation

$$9 i_1 - 5 i_2 = 10$$

$$\frac{171}{5} i_2 - 5 i_2 = 10$$

or
$$i_2 = \frac{10 \times 5}{146} \quad \text{or} \quad i_1 = \frac{190}{146} = 1.3 \text{ A}$$

Alternative solution:

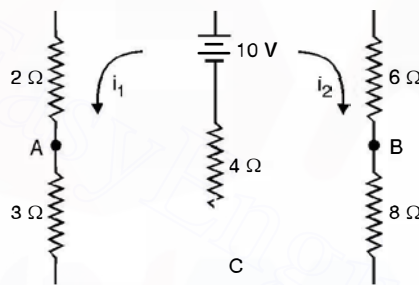

Fig. E2.4.1

Using KVL we have

$$9 i_1 + 4 i_2 = 10$$

$$4 i_1 + 18 i_2 = 10$$

or
$$9 i_1 + 4 i_2 = 4 i_1 + 18 i_2$$

or
$$i_1 = \frac{14}{5} i_2$$

Substituting in (1) we have

$$9 \times \frac{14}{5} + 4 i_2 = 10$$

or
$$i_2 = 0.343$$

and
$$i_1 = \frac{14}{5} \times \frac{50}{146} = 0.96 \text{ A}$$

Therefore current through the battery 1.303 A.

Potential of A w.r. to C $0.96 \times 3 = 2.88 \text{ v}$

and that of B w.r. to C $0.343 \times 8 = 2.744$

$V_{AB} = V_A - V_B = 2.88 - 2.74 = 0.14 \text{ v}$ **Ans.**

Example 2.5. Determine the current through the branch AB of the network shown

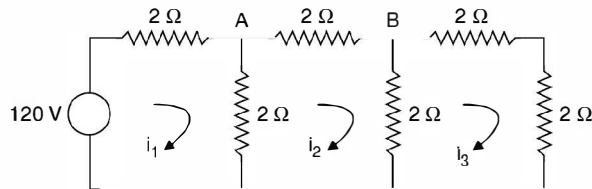

Fig. E2.5

Using KVL we have

$$\begin{bmatrix} 4 & -2 & 0 \\ -2 & 6 & -2 \\ 0 & -2 & 6 \end{bmatrix} \begin{bmatrix} i_1 \\ i_2 \\ i_3 \end{bmatrix} = \begin{bmatrix} 10 \\ 0 \\ 0 \end{bmatrix}$$

Using Cramer's rule

$$i_2 = \frac{\begin{vmatrix} 4 & 10 & 0 \\ -2 & 0 & -2 \\ 0 & 0 & 6 \end{vmatrix}}{\begin{vmatrix} 4 & -2 & 0 \\ -2 & 6 & -2 \\ 0 & -2 & 6 \end{vmatrix}} = \frac{15}{13} \text{ A Ans.}$$

2.5 NODAL ANALYSIS

We now illustrate the application of KCL for solving the networks. Here whenever a voltage source is given it should be converted into a current source before nodal equations using KCL are written.

Example 2.6. Determine the current in the branches of the network in Fig. E2.6 using nodal analysis.

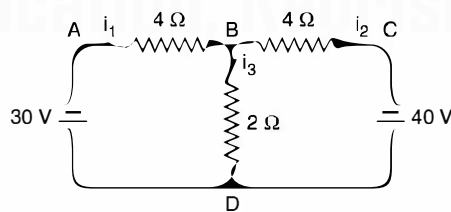

Fig. E2.6

Solution: There are four nodes A, B, C, D as shown in the network. Taking node D as reference, we are left with three nodes A, B and C. Voltages of nodes A and C with respect to reference node are known to be 30V and 40V respectively. Hence voltage of only one node is not-known. Hence we need write only one equation at node B.

$$i_1 + i_2 = i_3$$

$$\text{or } \frac{30 - V_B}{4} + \frac{40 - V_B}{4} = \frac{V_B}{2}$$

$$\text{or } 30 - V_B + 40 - V_B = 2V_B$$

$$\text{or } 4V_B = 70 \quad \text{or } V_B = 17.5 \text{ volts}$$

$$\text{Hence } i_1 = \frac{30 - 17.5}{4} = 3.125 \text{ A}$$

$$i_2 = \frac{40 - 17.5}{4} = 5.625$$

$$\text{and } i_3 = i_1 + i_2 = 8.75 \text{ A} \quad \text{Ans.}$$

Example 2.7. Determine the current's in all branches of the network shown in Fig. E2.7

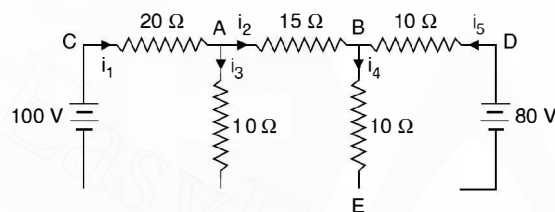

Fig. E2.7

Solution. Taking node E as reference and since the potentials of nodes C and D with respect to E are known hence only two independent nodes are A and B where the voltages be V_A and V_B respectively.

Writing nodal equation at node A

$$\frac{100 - V_A}{20} - \frac{V_A - V_B}{15} - \frac{V_A}{10} = 0$$

$$\text{or } 5 = \frac{V_A}{20} + \frac{V_A}{15} - \frac{V_B}{15} + \frac{V_A}{10}$$

$$25 = \frac{V_A}{4} + \frac{V_A}{3} - \frac{V_B}{3} + \frac{V_A}{2}$$

$$300 = 3V_A + 4V_A - 4V_B + 6V_A$$

$$\text{or } 13V_A - 4V_B = 300 \quad (1)$$

At node B

$$\frac{V_A - V_B}{15} + \frac{80 - V_B}{10} = \frac{V_B}{10}$$

$$\frac{V_A - V_B}{3} + \frac{80 - V_B}{2} = \frac{V_B}{2}$$

$$2V_A - 2V_B + 240 - 3V_B = 3V_B$$

$$2V_A - 8V_B = -240$$

$$\text{or } -V_A + 4V_B = 120 \quad \dots(2)$$

Adding equation (1) and (2) we have

$$12V_A = 420$$

$$V_A = 35 \text{ volts}$$

Hence $-35 + 4V_B = 120$

or $4V_B = 155$

or $V_B = 38.75 \text{ volts}$

Hence current $i_1 = \frac{100 - 35}{20} = \frac{65}{20} = 3.25 \text{ A}$

$$i_2 = \frac{35 - 38.75}{15} = -\frac{3.75}{15} = -0.25$$

The value of i_2 is coming out to be negative which means in the actual circuit the direction of current should be opposite to what is shown in Fig. E2.7

Hence $i_3 = i_1 + i_2 = 3.25 + 0.25 = 3.5$

$$i_4 = \frac{V_B}{10} = \frac{38.75}{10} = 3.875 \text{ A}$$

and hence $i_5 = i_2 + i_4 = 0.25 + 3.875$
 $= 4.125 \text{ Amp Ans.}$

Example 2.8. Consider example 2.5. The figure is reproduced here.

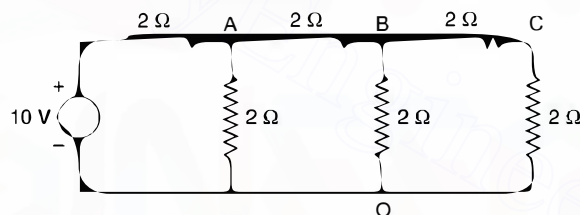

Fig. E2.8

First we transform the voltage source into a current source and the diagram becomes

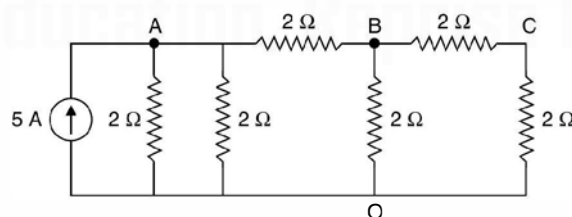

Fig. E2.8.1

Taking node O as reference, we write down KCL equations

At node A

$$\frac{V_A}{2} + \frac{V_A}{2} + \frac{V_A - V_B}{2} = 5$$

$$V_A \left[\frac{1}{2} + \frac{1}{2} + \frac{1}{2} \right] - V_B / 2 + 0 \cdot V_c = 5$$

$$\text{At node } B \quad -V_A/2 + \left(\frac{1}{2} + \frac{1}{2} + \frac{1}{2}\right) V_B - V_C/2 = 0$$

$$\text{At node } C \quad 0.V_A - \frac{V_B}{2} + V_C \left(\frac{1}{2} + \frac{1}{2}\right) = 0$$

These equations can be written in matrix form as follows:

$$\begin{bmatrix} \frac{1}{2} + \frac{1}{2} + \frac{1}{2} & -\frac{1}{2} & 0 \\ -\frac{1}{2} & \frac{1}{2} + \frac{1}{2} + \frac{1}{2} & -\frac{1}{2} \\ 0 & -\frac{1}{2} & \frac{1}{2} + \frac{1}{2} \end{bmatrix} \begin{bmatrix} V_A \\ V_B \\ V_C \end{bmatrix} = \begin{bmatrix} 5 \\ 0 \\ 0 \end{bmatrix}$$

Here the first matrix is known as nodal admittance matrix and is denoted by Y and the two column matrices are known as nodal voltage and nodal current matrices denoted by V and I respectively.

Hence, the above matrices can be written in compact form as

$$YV = I \quad \dots(2.22)$$

It can be seen that the nodal admittance matrix can be written simply by looking at the interconnections of the network using the following procedure:

- (i) The diagonal element of each node is the sum of the admittances connected to it.
- (ii) The off diagonal element is the negative admittance between the nodes. If there is no connection between the two nodes, the entry in the off-diagonal for both the nodes is zero i.e. if node i is not connected to the node j , then $Y_{ij} = Y_{ji} = 0$. In general every node will not be connected to all other nodes in the network and hence normally nodal admittance matrix is a highly sparse matrix i.e. it will have very small number of non-zero elements. In fact, in a large network consisting of say 100 nodes, these non zero elements would be as small as 2% of the total elements.

We come back to original problem of finding out V_{AB}

Using Cramer's rule

$$V_A = \frac{\begin{vmatrix} 5 & -\frac{1}{2} & 0 \\ 0 & \frac{3}{2} & -\frac{1}{2} \\ 0 & -\frac{1}{2} & 1 \end{vmatrix}}{\begin{vmatrix} \frac{3}{2} & -\frac{1}{2} & 0 \\ -\frac{1}{2} & \frac{3}{2} & -\frac{1}{2} \\ 0 & -\frac{1}{2} & 1 \end{vmatrix}} = \frac{5 \times \frac{5}{4}}{\frac{13}{8}}$$

Therefore, $V_A = \frac{50}{13}$ volts

Similarly,

$$V_B = \frac{\begin{vmatrix} \frac{3}{2} & 5 & 0 \\ -\frac{1}{2} & 0 & -\frac{1}{2} \\ 0 & 0 & 1 \end{vmatrix}}{\Delta}$$

Therefore, $V_B = \frac{5}{2} \times \frac{8}{13} = \frac{20}{13}$ and $V_{AB} = \frac{50}{13} - \frac{20}{13} = \frac{30}{13}$ volts

2.6 SUPERPOSITION THEOREM

This theorem is applicable to linear networks. A network is said to be linear where the response is proportional to the excitation. If X_1 is the excitation and Y_1 the response of a given network related by $Y_1 = CX_1$ and for an excitation X_2 the response Y_2 is related by $Y_2 = CX_2$ then for excitation $(X_1 + X_2)$ the response will be $Y_1 + Y_2$ for a linear network. It is to be noted that if the excitation and response are related by the linear equation $Y_1 = CX_1 + d_1$ the network is not linear as for double the excitation; response will not be doubled. Thus a circuit with R, L, C , elements with constant values and initially relaxed (for $L i(o) = 0$ and for $C V(o) = 0$) is a linear circuit. However, the initial conditions could be considered as sources or excitation and the overall response of the circuit can be obtained.

Superposition theorem can be stated as follows: In a linear network, if more than one number of sources (excitation) are acting, the response in a certain branch can be obtained by superimposing algebraically the responses due to various sources taking one excitation at a time and considering the remaining voltage sources (ideal) short circuited or replaced by their equivalent internal impedances and current sources (ideal) open circuited or replaced by their equivalent admittances.

The theorem is further illustrated with a few examples.

Example 2.9. Using superposition principle determine the current through 2Ω resistor connected between A and B shown in the circuit here.

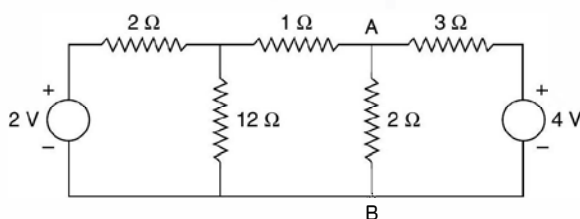

Fig. E2.9

Solution: Since there are two sources in the circuit, there will be two circuits for analysis purposes where in one source will be present and the other short circuited, being the voltage source.

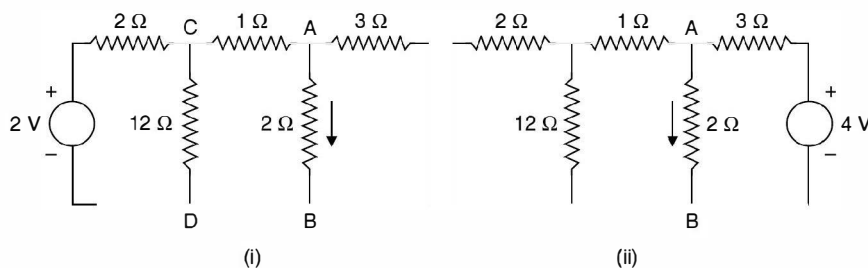

Fig. E2.9.1

The resistance between CD excluding $12\ \Omega$ resistance

$$1 + \frac{6}{5} = 1 + 1.2 = 2.2\ \Omega, \text{ including } 12\ \Omega \text{ resistance}$$

$$\frac{1}{R} = \frac{1}{12} + \frac{10}{22} = \frac{(11 + 60)}{132} = \frac{71}{132}$$

$$\text{Total resistance } 2 + \frac{132}{71} = \frac{(142 + 132)}{71} = \frac{274}{71}$$

$$\text{Therefore, current through the source is } \frac{2 \times 71}{274}$$

The current through $1\ \Omega$ resistor is

$$\frac{2 \times 71}{274} \times \frac{12 \times 10}{142} = \frac{120}{274}$$

Therefore current through $2\ \Omega$ resistor

$$\frac{120}{274} \times \frac{3}{5} = \frac{72}{274}\ \text{A}$$

(ii)

$$1 + \frac{24}{14} = \frac{38}{14}\ \Omega$$

$$\frac{1}{R} = \frac{1}{2} + \frac{14}{38} = \frac{(19 + 14)}{38} = \frac{33}{38}$$

or

$$R = \frac{38}{33}\ \Omega$$

$$\text{Total resistance } 3 + \frac{38}{33} = \frac{137}{33}\ \Omega$$

$$\text{Current through the source } \frac{4 \times 33}{137}\ \text{A}$$

Current through $2\ \Omega$ resistor

$$\frac{4 \times 33}{137} \times \frac{38}{14} \times \frac{14}{66} = \frac{76}{137}$$

Therefore, total current is

$$\frac{72}{274} + \frac{76}{137} = \frac{224}{274} = 0.8\ \text{A}$$

2.7 THEVENIN'S THEOREM

This theorem is most useful as many a times we may be interested in the current/voltage in a part of the otherwise a much more complex network. We may not be interested in the current/voltage through all the branches of the network e.g. determining fault current in a particular branch of a complex power system or finding out the value of load resistance for an electronic circuit which will result in the maximum power transferred to this load.

Thevenin's theorem can be explained with the help of two networks A and B connected as shown in Fig. 2.8.

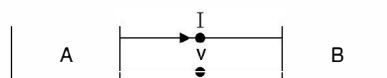

Fig. 2.8 Two networks A and B connected.

The original network can be considered as a combination and connection of networks A and B . Network A contains linear elements which may have initial conditions. It may also have an independent and dependent sources. However, there is no mutual magnetic coupling between the networks A and B nor does a controlled source in A couple to B .

For network B , the elements need not necessarily be linear. These could be non-linear or time varying or both. However, in our analysis we will assume that the network elements are linear and many a times this will be a single branch (load) of the network.

Network A is to be replaced by an equivalent network under the condition that the current I and voltage V identified in the Fig. remain invariant when the replacement is made. This amounts to replacing network A by an equivalent Thevenin's voltage source and an equivalent Thevenin's series impedance as shown in Fig. 2.8 (a).

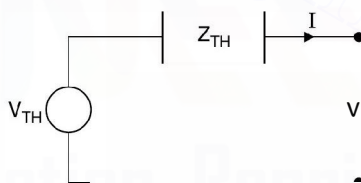

Fig. 2.8 (a) Thevenin equivalent of Fig. 2.8.

The following procedure is followed :

To determine V_{TH} we remove the network B (could be a load resistor or the element through which current is required) and solve the network A to find out voltage across the open circuited terminal. This voltage is the Thevenin's equivalent voltage source V_{TH} . Also Z_{eq} is the impedance as seen in the network between the two open circuited terminals replacing the voltage sources by their equivalent series impedances and the current sources by their equivalent shunt admittances. The impedance as seen is known as Thevenin's equivalent series impedance. While finding Thevenin's equivalent, dependent sources continue to operate in the network.

If Z_L is the load impedance and Z_{eq} the Thevenin's equivalent series impedance (Fig. 2.9) the current through the load impedance is given by

$$I = \frac{V_{TH}}{Z_{eq} + Z_L} \quad \dots(2.14)$$

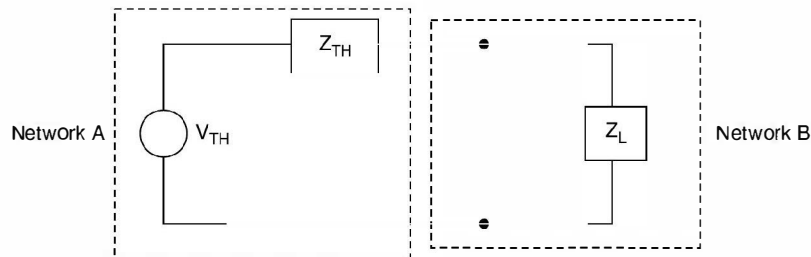

Fig. 2.9 Thevenin's equivalent with load.

A few examples will further illustrate the application of Thevenin's theorem.

Example 2.10. Determine the current through $2\ \Omega$ resistor connected between A and B in the circuit shown using Thevenin theorem.

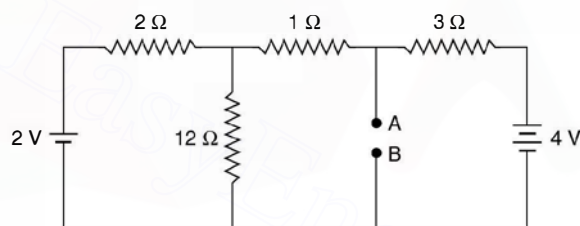

Fig. E2.10

Solution: To obtain V_{TH} refer Fig. below:

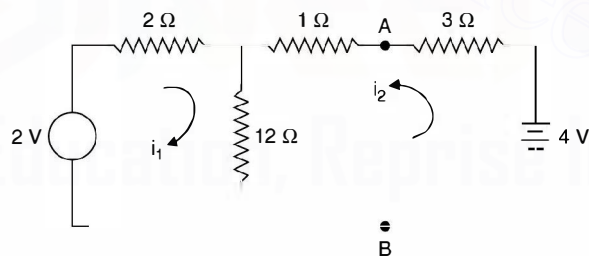

Fig. E2.10.1

$$2i_1 + 12(i_1 + i_2) = 2, \quad 4i_2 + 12i_1 + 12i_2 = 4$$

$$14i_1 + 12i_2 = 2 \quad \text{or} \quad 7i_1 + 6i_2 = 1$$

$$12i_1 + 16i_2 = 4 \quad \text{or} \quad 3i_1 + 4i_2 = 1 \quad \dots(1)$$

or

$$7i_1 + 6i_2 = 3i_1 + 4i_2$$

or

$$4i_1 = -2i_2$$

or

$$i_1 = \frac{-i_2}{2}$$

Substituting in (1) we have

$$\frac{-3i_2}{2} + 4i_2 = 1$$

or $\frac{5i_2}{2} = 1$ or $i_2 = \frac{2}{5}$ Amp.

Therefore, $V_{TH} = V_{AB} = 4 - \frac{2}{5} \times 3 = 2.8$ volt

The equivalent series resistance

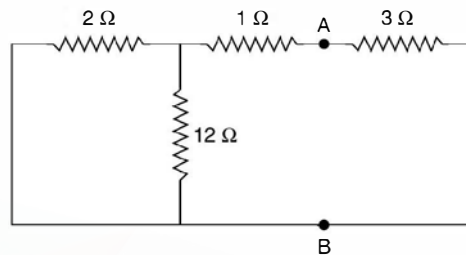

Fig. E2.10.2

$$\left(1 + \frac{24}{14}\right) \parallel 3 \quad \text{or} \quad \frac{\frac{38}{14} \times 3}{3 + \frac{38}{14}} = \frac{57}{40} \Omega$$

Thevenin's equivalent circuit is, therefore, as follows :

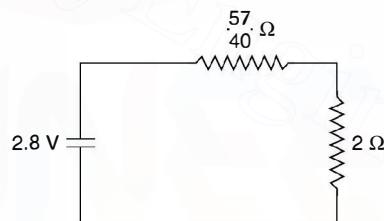

Fig. E2.10.3

Therefore, current through 2 Ω resistor

$$\frac{2.8}{\frac{57}{40} + 2} = 0.82 \text{ A}$$

Example 2.11. Determine the current through the branch AB of the network shown here using Thevenin's equivalent.

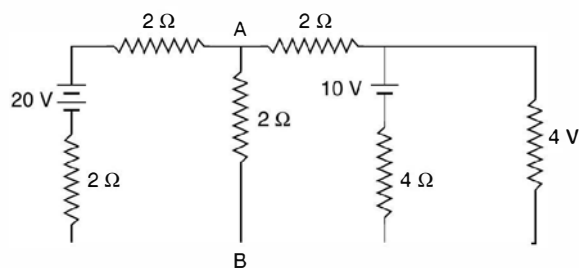

Fig. E2.11

Solution: To obtain V_{TH} the equivalent circuit is given as

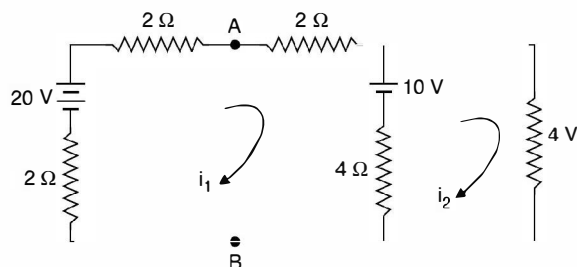

Fig. E 2.11.1

$$2i_1 - 20 + 4i_1 + 10 + 4(i_1 - i_2) = 0$$

$$10i_1 - 4i_2 = 10$$

or

$$5i_1 - 2i_2 = 5$$

$$4(i_2 - i_1) - 10 + 4i_2 = 0$$

$$-4i_1 + 8i_2 = 10$$

$$-2i_1 + 4i_2 = 5$$

or

$$-2i_1 + 4i_2 = 5i_1 - 2i_2$$

or

$$6i_2 = 7i_1, \quad -2i_1 + \frac{14}{3}i_1 = 5$$

or

$$i_2 = \frac{7}{6}i_1, \quad \frac{8}{3}i_1 = 5$$

$$V_{AB} + \frac{15}{2} = 20 \quad i_1 = \frac{15}{8},$$

$$V_{AB} = 12.5 \text{ V}$$

$$V_{AB} = V_{TH} = 12.5 \text{ volts}$$

Therefore,

To calculate R_{TH} or R_{eq}

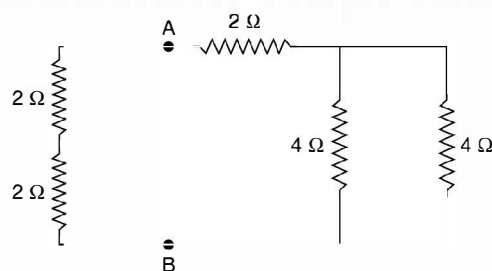

Fig. E2.11.2

Therefore current through the AB branch

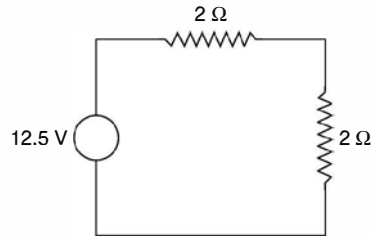

Fig. E2.11.3

$$I_{AB} = \frac{12.5}{4} = 3.125 \text{ A}$$

2.8 NORTON'S THEOREM

Norton's theorem is dual of Thevenin's theorem and can be stated as follows:

It states that any two terminal linear network can be replaced by an equivalent network consisting of a current source I_0 in parallel with a network of impedance Z_0 . The impedance is same as that found for Thevenin's equivalent and I_0 is the current between the two terminals when these terminals are short circuited. The following example will further clarify the concepts associated with the theorem.

Example 2.12. Determine the current through the resistance $R_L = 1, 2, 5 \Omega$ for the network shown in Fig. E 2.12. Using Thevenin's theorem.

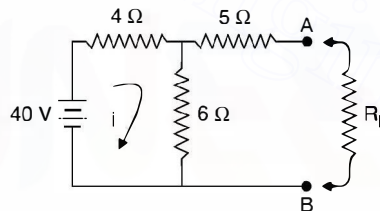

Fig. E2.12

Solution: We remove R_L from the network and obtain the equivalent Thevenin's voltage source i.e. the voltage across AB when R_L is removed and the Thevenin's equivalent series resistance which is the resistance as seen between AB into the network shorting the voltage sources.

To find out V_{TH}

When R_L is removed, there is one closed loop and hence the current in the loop is

$$i = \frac{40}{4 + 6} = 4 \text{ A}$$

Now when R_L is removed, voltage across terminals AB is the voltage across 6 Ω resistor i.e.

$$V_{TH} = 6 \times 4 = 24 \text{ V}$$

To find out the equivalent Thevenin series resistance the resulting circuit is

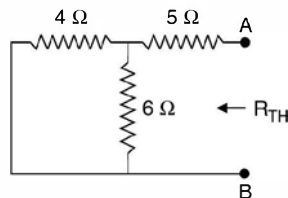

Fig. E2.12.1

$$\text{Hence } R_{TH} = 5 + \frac{6 \times 4}{10} = 7.4 \Omega$$

So the equivalent Thevenin's circuit is

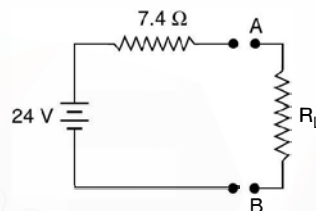

Fig. E2.12.2

$$\text{When } R_L = 0 \text{ Current in } R_L = \frac{24}{7.4} = 3.24 \text{ A}$$

$$\text{When } R_L = 2 \Omega \text{ Current in } R_L = \frac{24}{7.4 + 2} = \frac{24}{9.4} = 2.55 \text{ A}$$

$$\text{When } R_L = 5 \Omega \text{ Current in } R_L = \frac{24}{7.4 + 5} = \frac{24}{12.4} = 1.935 \text{ A} \quad \text{Ans.}$$

Example 2.13. Solve the network of example E 2.10 using Norton's theorem.

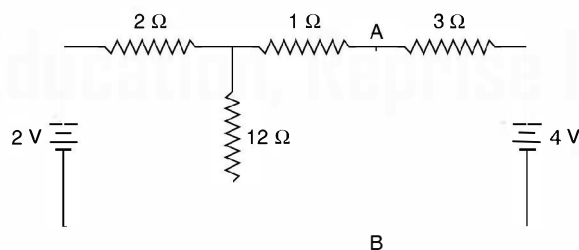

Fig. E2.13

Norton's equivalent current source will be the current through the short circuited branch AB .

Using superposition principle to find current through branch AB we first short circuit 2 V battery, the current through AB due to 4 volt will be $\frac{4}{3}$ A. When 4 volt battery is shorted, the current supplied by 2 V battery is

$$\frac{2}{2 + \frac{12}{13}} = \frac{26}{38}$$

Therefore current through AB will be $\frac{26}{38} \times \frac{12}{13} = \frac{12}{19}$ A

so total current is $\frac{4}{3} \times \frac{12}{19} = \frac{112}{57}$ A

So that Norton's equivalent current source is $112/57$ A. The Norton's equivalent impedance is same as in case of Thevenin's equivalent impedance except that it is to be connected across the current source. Along with this the resistance through which current is required should be connected across the current source. This forms the complete equivalent Norton's circuit and is drawn here.

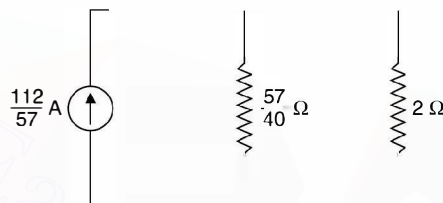

Fig. E2.13.1

Current through 2Ω resistor is

$$\begin{aligned} \frac{112}{57} \times \frac{57}{40} \times \frac{1}{\frac{57}{40} + 2} \\ = \frac{112}{137} = 0.82 \text{ A} \end{aligned}$$

Example 2.14. For the network shown in Example 2.12, determine the current in $R_L = 0, 2, 5 \Omega$ using Norton's theorem.

Solution: To obtain the Norton's equivalent circuit, following circuit would be used

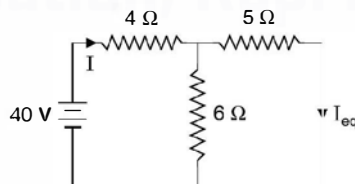

Fig. E2.14

$$\text{Current } I = \frac{40}{4 + \frac{30}{11}} = \frac{440}{74} = 5.946 \text{ A}$$

$$\text{Hence } I_{eq} = \frac{440}{74} \times \frac{6}{11} = 3.243$$

The equivalent Norton's resistance is same as in Thevenin's equivalent i.e. 7.4Ω . The Norton's equivalent circuit is

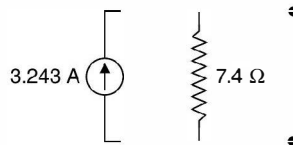

Fig. E2.14.1

Now current through R_L when $R_L = 0$. Obviously the total current will flow through R_L and no current through resistance 7.4Ω

$$R_L = 2\Omega, \text{ current through } R_L = 3.243 \times \frac{7.4}{9.4} = 2.55 \text{ A}$$

$$R_L = 5 \Omega \text{ current through } R_L = 3.243 \times \frac{7.4}{12.4} = 1.935 \text{ A}$$

Example 2.15. Solve example 2.11 using Norton's theorem.

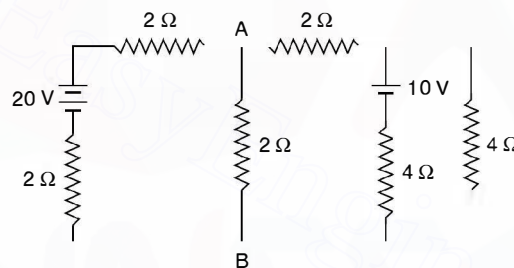

Fig. E2.15

Solution: Shorting branch AB and using superposition principle to find current through AB .

20 Volts in the circuit and shorting 10 volt source

$$\text{The current is } \frac{20}{4} \text{ A} = 5 \text{ A}$$

10 volts in the circuit and shorting 20 V

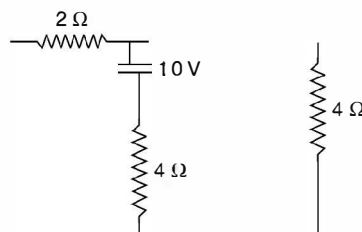

Fig. E2.15.1

Current supplied by the battery

$$\frac{10}{4 + 4/3} = \frac{3 \times 10}{16} = \frac{15}{8} \text{ A}$$

Current through 2Ω resistor

$$\frac{15}{8} \times \frac{4}{6} = \frac{5}{4} \text{ A}$$

Total current through AB is

$$5 + \frac{5}{4} = \frac{25}{4} \text{ A}$$

The Norton's equivalent circuit, therefore is

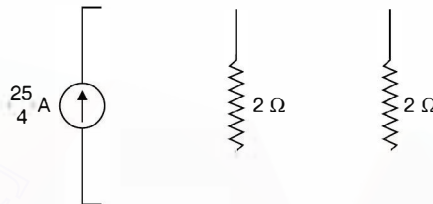

Fig. E 2.15.2

Therefore, current through AB branch is

$$\frac{25}{4} \times \frac{1}{2} = \frac{25}{8} = 3.125 \text{ A}$$

2.9 MAXIMUM POWER TRANSFER THEOREM

Sometimes in electronics circuits it is desirable to transfer maximum power through a source to a load e.g. impedance matching is carried out in a loud speaker so that maximum sound could be heard. However in power system maximum power transfer is never tried as huge amount of power in terms of MW are transferred from source to the load and the efficiency of transfer is 50% as will be seen shortly if power transferred is based on maximum power transfer criterion. Also under this, the terminal voltage becomes half of the source voltage and hence this results in poor voltage regulation, therefore, maximum power transfer criterion is never considered in power system.

We will consider the theorem both for d.c. and a.c. circuits.

d.c. circuits :

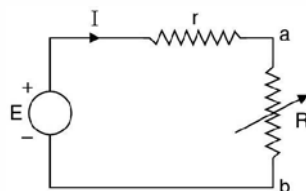

Fig. 2.10 Maximum power transfer-d.c. circuit.

Here r is the internal resistance of the source or the equivalent resistance as seen between a b or the load resistance R . Usually r in a circuit or in a system is fixed, the load resistance R is variable.

The problem is : what should be R expressed in terms of r so that power delivered to the load resistance is maximum.

The current in the circuit $I = E/(r + R)$ and power transferred is

$$P = \frac{E^2}{(r + R)^2} \cdot R$$

For this power to be maximum $\frac{dP}{dR} = 0$

$$= \frac{E^2[(r + R)^2 - R \cdot 2(R + r)]}{(r + R)^4} = 0$$

or $r + R - 2R = 0$

or $R = r$ (2.22)

This shows that for maximum power transfer the load resistance R should equal the internal resistance r or the equivalent resistance r . Under this condition

Power $P_{max} = \frac{E^2}{(2r)^2} \cdot r = \frac{E^2}{4r}$

Same amount of power is dissipated in the internal resistance r and hence the efficiency is 50%. Also it can be seen that voltage across the load is $\frac{E}{2}$ and voltage regulation is 50% which is very poor in power system operation.

a.c. Circuits:

(i) Load is $R + jX$ and internal impedance $(r + jx)$

Therefore, $I = \frac{E}{(r + R) + j(x + X)}$

Power transfer $P = I^2 R = \frac{E^2 R}{(r + R)^2 + (x + X)^2}$... (2.23)

For power to be maximum $\frac{\partial P}{\partial X} = 0$

$$= \frac{E^2 R \cdot \{-2(x + X)\}}{D^2} = 0$$

or $x + X = 0$ or $X = -x$... (2.24)

which means the load reactance must be equal to the negated value of the source internal reactance. The maximum power becomes

$$P_{max} = \frac{E^2 R}{(r + R)^2}$$
 ... (2.25)

Again taking $\frac{dP}{dR} = 0$ for maximum power

We have just now seen the condition is $R = r$ and, therefore, in a.c. circuits the load impedance should be complex conjugate of the internal impedance that is $Z_L = Z_I^*$ where Z_L is the load impedance and Z_I is source impedance. Usually source impedance is inductive $r + jx$ and, therefore, the load impedance should be capacitive for maximum power transfer condition. Here again the efficiency is 50%.

(ii) Load resistance R and internal impedance $(r + jx)$

$$\text{Here current } I = \frac{E}{(r + R) + jx}$$

$$\text{And power } P = \frac{E^2 R}{(r + R)^2 + x^2} \quad \dots(2.26)$$

Therefore, $\frac{dP}{dR} = 0$ for maximum power transfer

$$E^2 \{ (r + R)^2 + x^2 \} - R \cdot 2(R + r) = 0$$

$$\text{or } r^2 + x^2 = R^2$$

$$\text{or } R = \sqrt{r^2 + x^2} = Z_I \quad \dots(2.27)$$

This means when load resistance R equals the impedance of the source the power transfer is maximum. Let us find out the magnitude of power under this condition

$$\begin{aligned} P &= \frac{E^2 Z_I}{(r + Z_I)^2 + x^2} = \frac{E I_{sc} Z_I^2}{r^2 + Z_I^2 + 2rZ_I + x^2} \\ &= \frac{E I_{sc} Z_I^2}{2Z_I^2 + 2rZ_I} = \frac{E I_{sc} Z_I}{2(Z_I + r)} \end{aligned} \quad \dots(2.28)$$

This power is certainly less than the power under the previous two conditions.

Example 2.16. Determine the current in the 2Ω resistor branch of the network using superposition theorem.

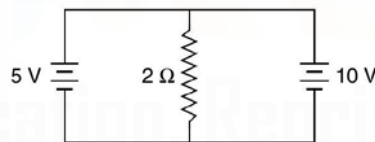

Fig. E2.16

Solution: By simple logic it can be said that the current through 2Ω resistor is zero as two voltage sources of unequal magnitude (dc) should not be connected in parallel as they act short circuit for each other.

The equivalent circuits using superposition principle are



Fig. E2.16.1

Hence current through $2\ \Omega$ resistor is zero.

Example 2.17. Determine the value of R_L in the network shown for maximum power transfer and calculate the value of power.

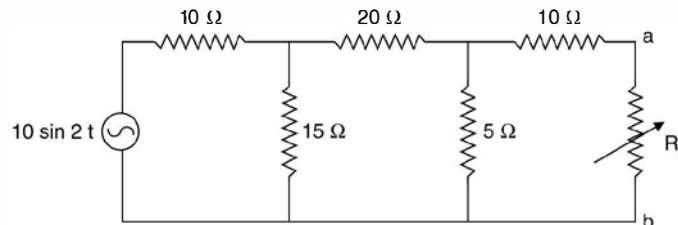

Fig. E2.17

Solution: For maximum power transfer, the resistance should equal the resistance between $a\ b$ when looked into the network replacing the voltage source by a short circuit.

$$\frac{10 \times 15}{25} + 20 = 26\ \Omega$$

$$r_{ab} = \frac{26 \times 5}{31} + 10 = 14.2\ \Omega$$

$$V_{TH} = \frac{10}{\sqrt{2}} \times \frac{8}{155} \times \frac{15}{40} \times 5 = 0.684\ \text{volt}$$

$$\text{Power transfer} = \frac{V^2}{4 r_{ab}} = \frac{(0.684)^2}{4 \times 14.2} = 8.24\ \text{mW} \quad \text{Ans.}$$

Example 2.18. Determine delta equivalent of the star circuit shown here in Fig. E 2.18.

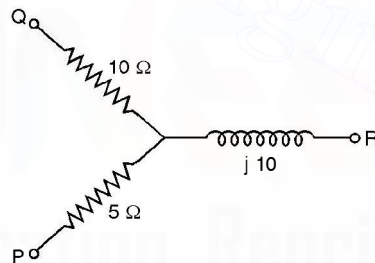

Fig. E2.18

Solution:

$$Z_{PQ} = \frac{Z_P Z_Q + Z_Q Z_R + Z_R Z_P}{Z_R}$$

$$= \frac{5 \times 10 + 10(j10) + 5(j10)}{j10}$$

$$= \frac{50 + j100 + j50}{j10} = \frac{j(5 + j15)}{j}$$

$$= -j5 + 15\ \Omega = 15 - j5$$

$$Z_{QR} = \frac{50 + j150}{5} = 10 + j30\ \Omega$$

$$Z_{PR} = \frac{50 + j150}{10} = (5 + j15)\ \Omega \quad \text{Ans.}$$

Example 2.19. Determine the star equivalent of the delta circuit shown in E 2.19.

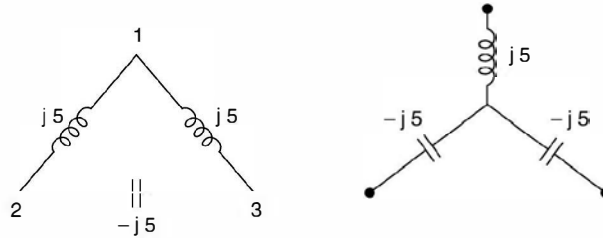

Fig. E2.19

Solution:

$$Z_1 = \frac{(j5)(j5)}{j5 + j5 - j5} = j5$$

$$Z_2 = \frac{(j5)(-j5)}{j5} = -j5$$

$$Z_3 = \frac{(j5)(-j5)}{j5} = -j5 \quad \text{Ans.}$$

Example 2.20. Determine the equivalent resistance between the terminals X and Y of the circuit shown using star-delta transformation.

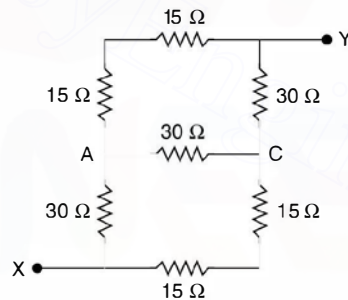

Fig. E2.20

Solution:

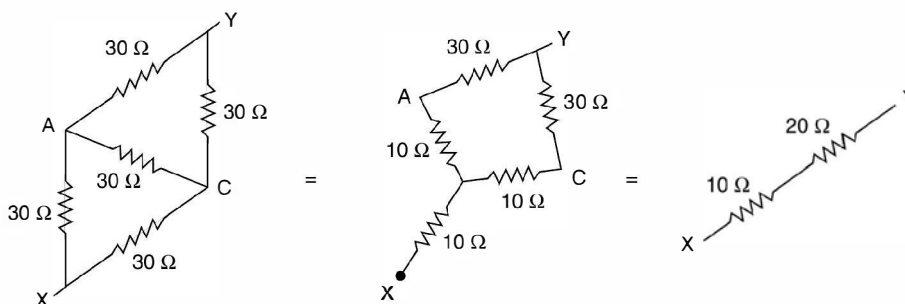

Fig. E2.20.1

Hence the total resistance between X and Y is 30 Ω . **Ans.**

Example 2.21. Determine the current through the branch AB of the network using (i) Simple Logic (ii) Loop Method of analysis (iii) Nodal Method of analysis

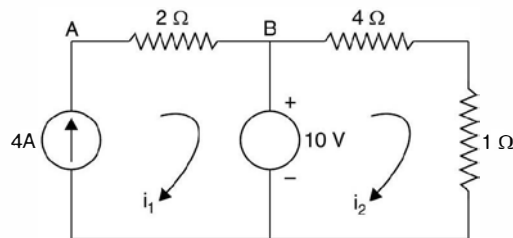

Fig. E2.21

(i) Since current source of $4A$ is connected in series with the branch AB , the current through branch AB will be $4A$. Similarly since a resistance of $(4 + 1) = 5$ is connected across a constant voltage source of $10V$, current $i_2 = \frac{10}{5} = 2A$.

(ii) *Loop analysis:* Here the current source should be converted into a voltage source. Since no resistance is connected across the current source, the transformation is not possible. Let us connect resistance R across the current source, and after the final result is obtained we will tend R to infinity. The circuit therefore, with voltage source will be as follows.

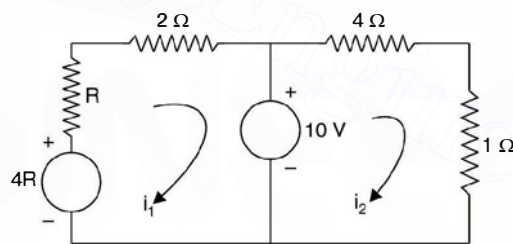

Fig. E2.21.1

$$\begin{bmatrix} R+2 & 0 \\ 0 & 5 \end{bmatrix} \begin{bmatrix} i_1 \\ i_2 \end{bmatrix} = \begin{bmatrix} 4R-10 \\ 10 \end{bmatrix}$$

$$i_1 = \frac{4R-10}{R+2} = \frac{4-10/R}{1+2/R} = 4A$$

$$\text{Lt } R \rightarrow \infty$$

(iii) *Nodal Analysis:* Here voltage source should be converted into current source.

Consider a resistance R connected in series with the voltage and towards the end we will have the result when $R \rightarrow 0$. The circuit is

Writing nodal equations

$$\begin{bmatrix} 1/2 & -1/2 & 0 \\ -1/2 & 1/2 + 1/4 + 1/R & -1/4 \\ 0 & -1/4 & 1 + 1/4 \end{bmatrix} \begin{bmatrix} V_1 \\ V_2 \\ V_3 \end{bmatrix} = \begin{bmatrix} 4 \\ 10/R \\ 0 \end{bmatrix}$$

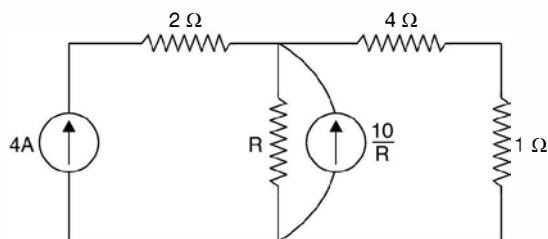

Fig. E2.21.2

$$V_1 = \frac{\begin{vmatrix} 4 & -1/2 & b \\ 10/R & 3/4 + 1/R & -1/4 \\ 0 & -1/4 & 5/4 \end{vmatrix}}{\begin{vmatrix} 1/2 & -1/2 & 0 \\ -1/2 & 3/4 + 1/R & -1/4 \\ 0 & -1/4 & 5/4 \end{vmatrix}} = \frac{7/2 + 45/4R}{1/8 + 5/8R}$$

$$V_2 = \frac{\begin{vmatrix} 1/2 & 4 & 0 \\ -1/2 & 10/R & -1/4 \\ 0 & 0 & 5/4 \end{vmatrix}}{\Delta} = \frac{25/4R + 5/2}{1/8 + 5/8R}$$

$$V_1 - V_2 = \frac{5/R + 1}{1/8 + 5/8R} = \frac{8(R+5)}{5+8R} = 8$$

$$\text{Lt } R \rightarrow 0$$

The voltage difference is 8 volt. Therefore current is $\frac{8}{2} = 4\text{A}$

Similarly current i_2 can be obtained.

(iv) By shifting the voltage source

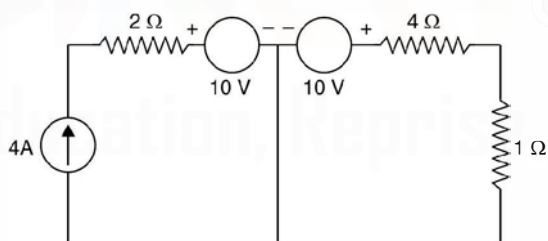

Fig. E2.21.3

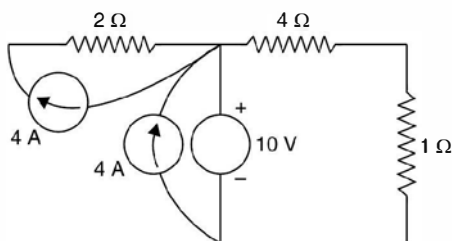

Fig. E2.21.4

Again through 2 ohm resistor the current is 4A and that through 4 ohm resistor it is $\frac{10}{2} = 2A$.

Example 2.22. Determine the current through the 2 Ω resistor branch of the given network.

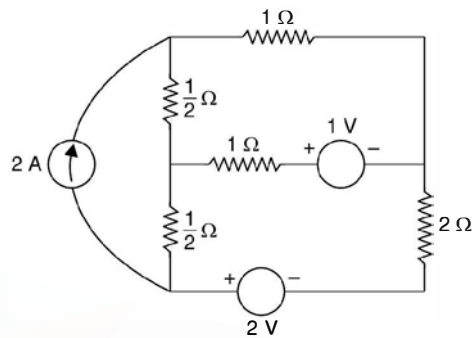

Fig. E2.22

Solution: Transforming the current source into a voltage source we have

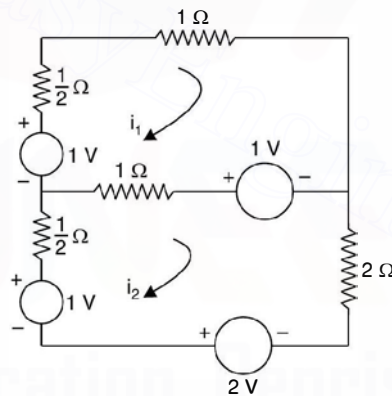

Fig. E2.22.1

$$\begin{bmatrix} 5/2 & -1 \\ -1 & 7/2 \end{bmatrix} \begin{bmatrix} i_1 \\ i_2 \end{bmatrix} = \begin{bmatrix} 2 \\ 2 \end{bmatrix}$$

$$\frac{\begin{vmatrix} 5/2 & 2 \\ -1 & 2 \end{vmatrix}}{\begin{vmatrix} 5/2 & -1 \\ -1 & 7/2 \end{vmatrix}} = \frac{7}{31/4} = \frac{28}{31} \text{ A}$$

Example 2.23. For the circuit shown in Fig. E2.23 determine (i) voltage v (ii) current through the 3 Ω resistor using nodal analysis.

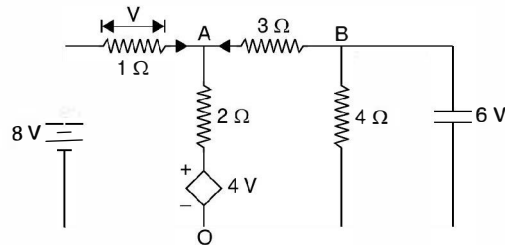

Fig. E2.23

Solution: Taking node O as reference and applying KCL at node A we have

$$\frac{8 - V_A}{1} + \frac{V_B - V_A}{3} = \frac{V_A - 4}{2}$$

Now $V = (8 - V_A)$ and $V_B = -6$ volt

Substituting these values we have

$$\begin{aligned} \frac{8 - V_A}{1} + \frac{-6 - V_A}{3} &= \frac{V_A - 4(8 - V_A)}{2} \\ 48 - 6V_A - 12 - 2V_A &= 3V_A - 96 + 12V_A \\ 48 - 12 + 96 &= 15V_A + 8V_A = 23V_A \\ 132 &= 23V_A \end{aligned}$$

or

$$V_A = \frac{132}{23}$$

Hence

$$V = 8 - V_A = 8 - \frac{132}{23} = \frac{52}{23}$$

and current through 3Ω resistor is

$$\frac{V_B - V_A}{3} = \frac{-6 - 132/23}{3} = -3.9A \quad \text{Ans.}$$

i.e. the direction of current is opposite to what is shown in the Fig. E2.23.

Example 2.24. Determine the current through 10Ω resistance of the circuit shown in Fig. E 2.24 using Thevenins theorem.

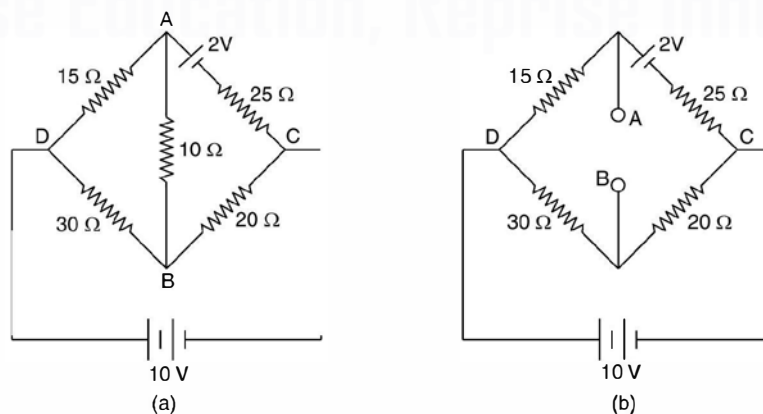

Fig. E2.24

Solution: To find out V_{AB} , the Thevenin's equivalent voltage source, we find V_{AC} and V_{BC} and then

$$V_{AB} = V_{AC} - V_{BC}$$

$$V_{AC} = \frac{10 - 2}{40} \times 25 + 2 = 5 + 2 = 7$$

and
$$V_{BC} = \frac{10}{50} \times 20 = 4 \text{ volt}$$

Therefore,
$$V_{AB} = 7 - 4 = 3 \text{ volts}$$

To obtain Thevenin's equivalent resistance as seen between AB , shorting the voltage sources, the equivalent circuit is as shown in Fig. E2.24c.

The equivalent resistance is

$$\frac{15 \times 25}{40} + \frac{30 \times 20}{50}$$

$$9.375 + 12 = 21.375$$

Hence current from A to B is

$$\frac{3}{21.375 + 10} = 95.6 \text{ mA} \quad \text{Ans.}$$

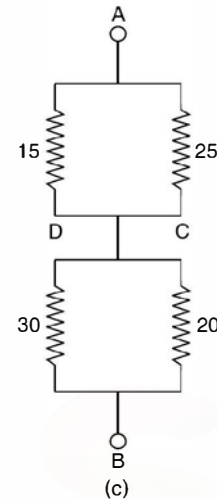

Fig. E2.24c

PROBLEMS

- 2.1. Determine the current in the battery, the current in each branch and the potential difference across AB in the network shown using loop analysis.

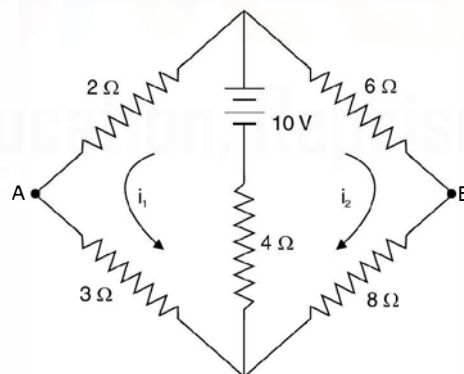

Fig. P2.1

[Ans. $i_1 = 0.96\text{A}$, $i_2 = 0.343\text{A}$, $V_{AB} = 0.14\text{V}$]

- 2.2. In the network shown determine the direction and magnitude of current flow in the ammeter A having a resistance of $10\ \Omega$.

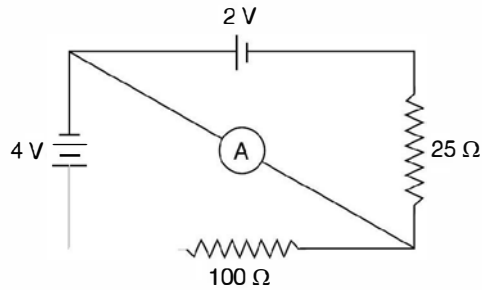

Fig. P2.2

[Ans. 26.7 mA]

2.3. Determine the current in all the branches of the network shown in Fig. P. 2.3 using loop analysis.

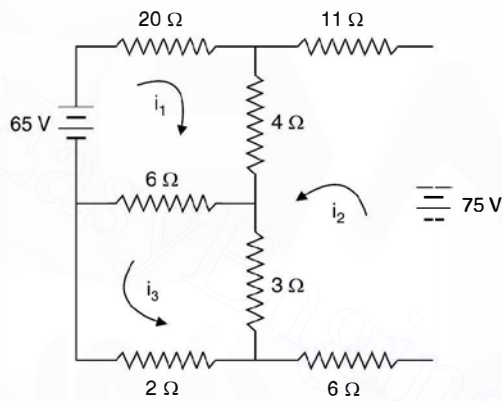

Fig. P2.3

[Ans. 1.844 A, 2.787 A, - 0.246A]

2.4 In the network shown determine the current using loop analysis.

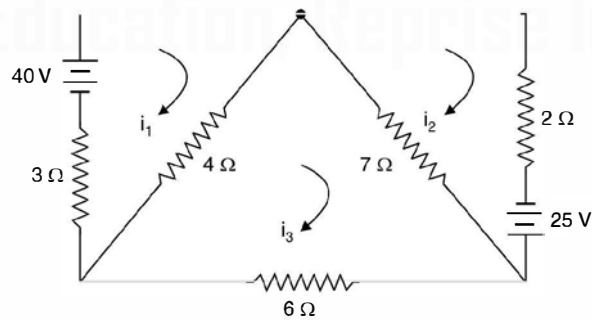

Fig. P2.4

[Ans. 8.32 A, 6.32 A, 4.56 A]

2.5. Find the currents I_1 , I_2 and I_3 and the voltage V_1 and V_2 in the given network using nodal analysis.

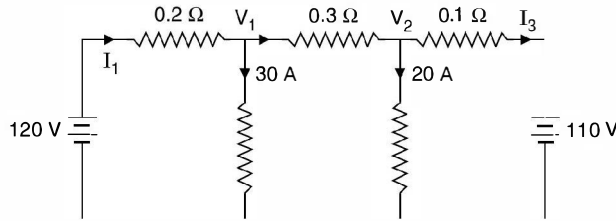

Fig. P2.5

[Ans. $I_1 = 40\text{A}$, $I_2 = I_3 = 10\text{A}$, $V_1 = 112\text{V}$, $V_2 = 109\text{V}$]

2.6. In the network shown in P. 2.6 determine currents in various branches using nodal analysis.

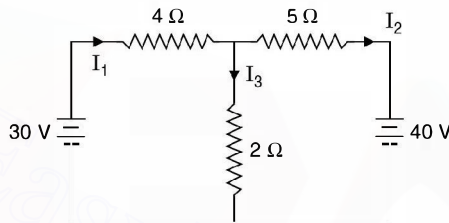

Fig. P2.6

[Ans. $I_1 = 3.42\text{A}$, $I_2 = -4.74$, $I_3 = 8.16\text{A}$]

2.7. In the networks shown determine the branch currents using nodal analysis.

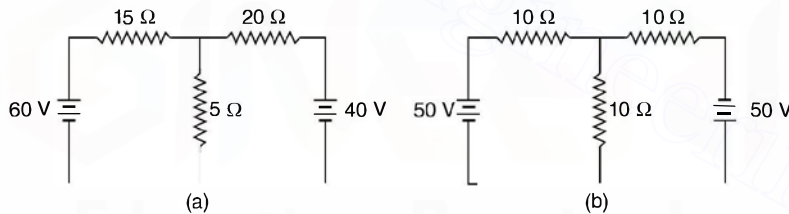

Fig. P2.7 (a) and (b)

[Ans. (a) 2.74, 1.05, 3.79 A, (b) 5A, 0A, 5A]

2.8. Determine the branch current in the networks shown using nodal analysis.

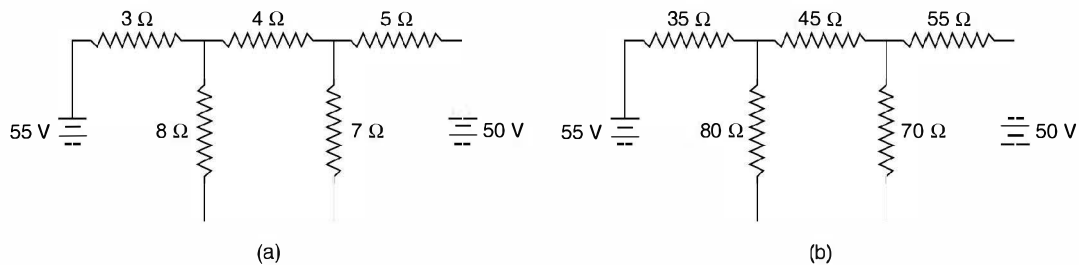

Fig. P2.8 (a) and (b)

[Ans. 5.866, 1.19, 4.675, 3.472, 4.662, (b) 0.938, 0.661, 0.277, 0.1089, 0.7705]

- 2.9. Determine the difference of potential between the points X and Y in the network shown.

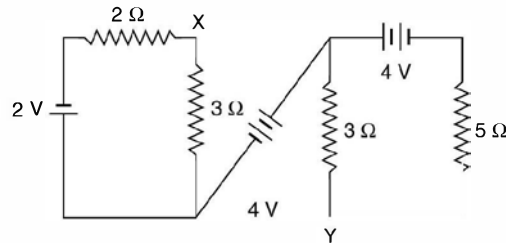

Fig. P2.9

[Ans. Y is 3.7 V + ve w.r.t. X]

- 2.10. Determine the equivalent (a) Thevenin's and (b) Norton's circuits which may be used to represent the given network at the terminals AB .

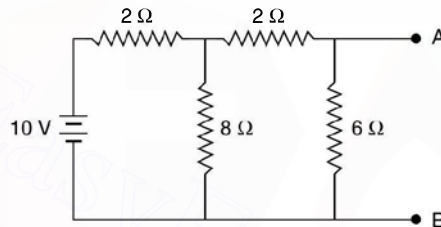

Fig. P2.10

[Ans. (a) 5V 2.25 Ω (b) 2.22 A, 2.25 Ω]

- 2.11. Determine the current through 3 Ω resistor branch as shown in Fig. P 2.11 using (a) Thevenin's theorem (b) Norton's theorem.

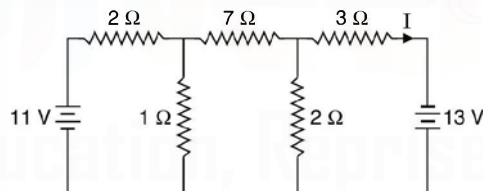

Fig. P2.11

[Ans. 3.03 A]

- 2.12. Determine the equivalent circuit and the current in R_L by (a) Thevenin's theorem (b) Norton's theorem, E is 100 V and all resistors in the circuit have the value of 20 Ω .

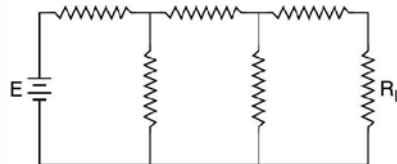

Fig. P2.12

[Ans. 0.385 A]

- 2.13. Determine the current in the 100 ohm resistor using (a) Thevenin's theorem (b) Norton's theorem.

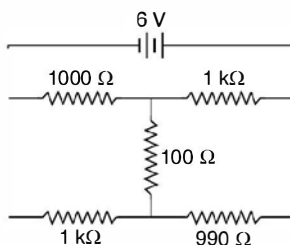

Fig. P2.13

[Ans. 13.7 μ A]

- 2.14. Determine the value of R_L for maximum power transfer and determine this maximum power for the circuit given.

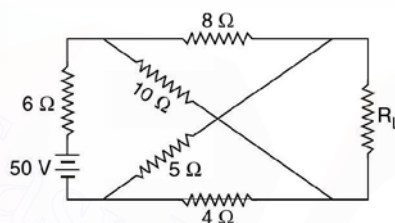

Fig. P2.14

[Ans. 6.67 Ω , 0.257 watt.]

- 2.15. Determine the resistance between the terminals AB of the network shown.

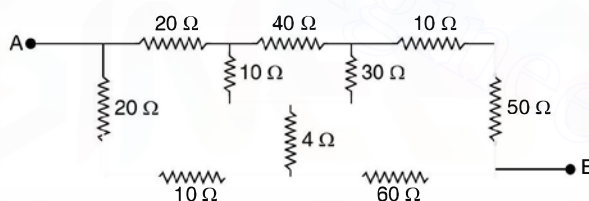

Fig. P2.15

[Ans. 47.2 Ω]

- 2.16. Determine the resistance between the terminals A and B if the resistance of each branch is 6 Ω in the given circuit.

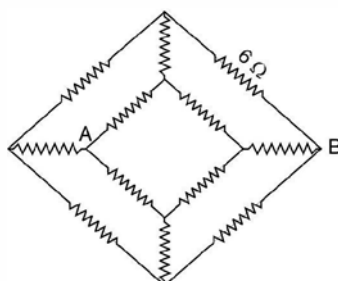

Fig. P2.16

[Ans. 5 Ω]

158

ELECTRICAL ENGINEERING

- 2.17. Determine the current through $10\ \Omega$ resistor in the network by (i) star-delta transformation (ii) Thevenin's theorem.

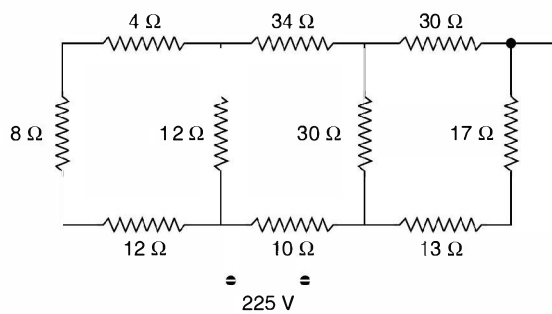

Fig. P2.17

[Ans. 5 A]

- 2.18. Determine the current through $2.5\ \Omega$ resistor using Thevenin's and Norton's theorem in the network shown.

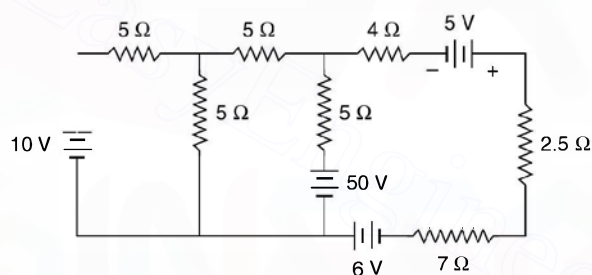

Fig. P2.18

[Ans. 2.44 A]

- 2.19. Determine X_1 and X_2 in terms of R_1 and R_2 to give maximum power dissipation in R_2 .

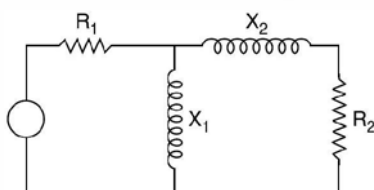

Fig. P2.19

$$[\text{Ans. } X_1 = \sqrt{R_1^2 R_2 / (R_1 - R_2)}, X_2 = \sqrt{R_2 (R_1 - R_2)}]$$

- 2.20. Determine the current through the branch $a b$ using Thevenin's theorem and superposition theorem.

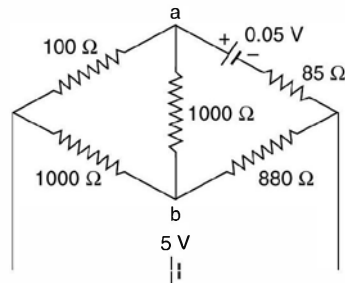

Fig. P2.20

[Ans. 10.62 A]

- 2.21. A load of $(20 - jX_C)$ is supplied from a source of 10 V rms and internal impedance $(10 + j20)$. Determine the value of X_C for maximum power supplied to the load and determine this power.
[Ans. 20 Ω , 2.22 W]
- 2.22. Two reactors each of 50 Ω reactance and negligible resistance are connected in series across a 200 V 50 Hz supply. Determine the value of resistance to be connected in parallel with one of the coils for maximum power dissipation.
[Ans. 25 Ω]
- 2.23. A source of voltage $2\sqrt{2} \sin 2t$ has an internal impedance $R = 1 \Omega$ and $L = 1/3$ H. It is connected to a load having parallel combination of C and resistance of 1 Ω . Determine C for maximum power consumption in 1 Ω load resistance.
[Ans. $\frac{1}{13}$ F]
- 2.24. In the circuit shown R_g is variable between 2 Ω and 55 Ω . What value of R_g results in maximum power transfer to the load R_L ?

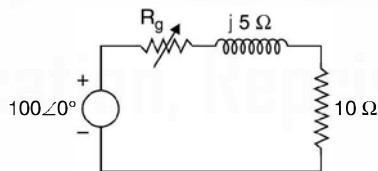

Fig. P2.24

[Ans. 8.66 Ω , 268 W]

CHAPTER

3

Three Phase Supply

3.1 THREE PHASE CIRCUITS

The use of d.c. for day to day application is much older than that of a.c. The first Central Electric Station was installed by Edison in New York in 1882 which operated at 110 V d.c.

The use of transformers for transmitting power over longer distances and higher voltages justified the use of 3-phase a.c. especially when the source of energy is at a far off place from the place of load centers and the power to be transmitted is in terms of thousands of MW.

A 3-phase circuit is more efficient, reliable and cost effective as compared to 1-phase system. A 3-phase circuit would obviously require a 3-phase supply. Hence a brief review of how 3-phase voltages are generated will not be out of place even though the book is only on analysis aspects of 3-phase circuits.

Generation of 3-phase voltages is also based on Faraday's laws of electromagnetic induction. Here the coil where the voltage is induced, is stationary whereas the magnetic field of the constant magnitude is made to rotate. This arrangement is preferred as the voltages induced are in terms of kilovolt and the currents to be handled by the winding are of large magnitude depending upon the size of the generator. The largest size of the generator (3-phase) in this country is of 500 MW capacity. Therefore, this winding is made stationary whereas the field winding which normally operates at relatively much lower voltage and currents is made rotating.

Fig. 3.1 shows an elementary 3-phase generator or alternator. Fig. 3.1 shows a two-pole rotor, the field winding of which is fed from a d.c. source to create magnetic flux for the poles. The poles are so shaped that these produce sinusoidal flux in space. The stator has a balanced three-phase winding with the axis of each phase displaced by 120° . The stator winding is balanced if the machine is mechanically symmetrical and if the electrical characteristics of the three coils are identical. The complete winding is represented in Fig. 3.1 by a single coil for simplicity.

Now, if the rotor is driven by a prime mover in the anticlockwise direction as shown, at synchronous speed, the voltage induced in the coil will be $v \times Bl$ and the direction of emf. induced will be given as per Flemmings right hand rule or by the cross product $v \times B$ rule.

With this rule the induced emf. in the coil sides $a b' c'$ is directed outside the paper whereas in coil sides $a'bc$ it is directed into the paper. Also since coil side a and a' are located along the pole axis where the flux density is maximum, the induced emf. in phase ' a ' is maximum.

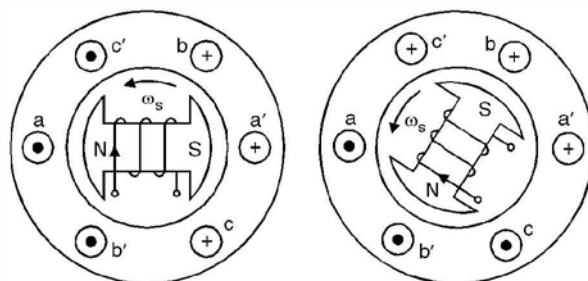

Fig. 3.1. (a) Voltage induced when pole axis along aa'
(b) Voltage induced when pole axis along bb' .

The corresponding emf. induced in phase b as identified by coil side b is found to be of opposite sign and of smaller magnitude. The magnitude is smaller as the flux density at the same instant is smaller as compared to what it is along the axis of the pole. In fact the distribution of B is cosinusoidal when it is maximum along the axis aa' , it will have a value $B/2$ along bb' as the angle between a and b is 60° and $\cos 60^\circ = \frac{1}{2}$. A similar reasoning yields the same results for phase c . It is to be noted that the angles given here are electrical degrees. However, for a two pole rotor, the electrical angles are equal to mechanical angles.

Next consider that the rotor has advanced 60° in counterclockwise direction. Now, North Pole coincides with b' and south pole with b indicating that the induced emf. is now a negative maximum in phase b . In the first position it was $-Vm/2$ now it becomes $-Vm$. Also coil cc' now comes under the influence of flux of reversed polarity as shown in Fig. 3.1(b). Hence the direction of the induced emf. in c is now out of the paper and into the paper for c' . The instantaneous values of the three phase voltages for the first and second time instants are shown in Fig. 3.2(d) and are identified as t_1 and t_2 respectively. By repeating the procedure as outlined above for various instants and plotting the results for each instant of time we obtain the curves for the three phases as shown in Fig. 3.2 (a)–(c). It is to be noted that the differences between the voltages of the three coils is not in the amplitude or waveform or the frequency but a time difference between the three waveforms. One complete rotation of the rotor gives one cycle of the voltage wave as shown by dotted vertical line.

Physical connection of the ends of each phase (points a' , b' , c') gives a Y-connection or Wye connection of the stator winding.

Fig. 3.2(d) shows the typical pattern of three phase system of voltages when the three waveforms are drawn on the same time axis. These waveforms can also be developed as the projections of the rotating phasor as shown in Fig. 3.2(e). In our analysis we will always assume that we have a 3-phase supply i.e. the three voltages $Ea'a$, $Eb'b$ and $Ec'c$ are equal in magnitude and displaced in time phase by 120° .

In a basic alternator the three coil ends a' , b' , c' are tied together and brought externally to a common lead called the neutral N . Leads a , b and c are brought externally to line terminals called phase a , phase b and phase c as shown in Fig. 3.3. The three phase voltages are specifically 120° apart. First phase a has positive maximum value, next phase b has its maximum positive value and another 120° time apart phase c has a positive maximum value. If the

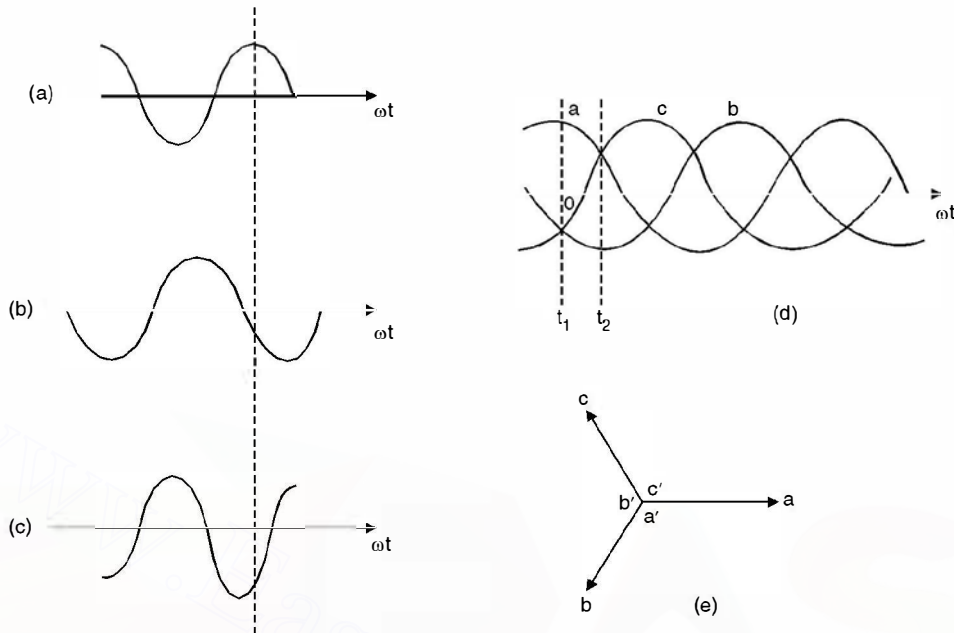

Fig. 3.2 (a) Voltage in phase *a*, (b) and (c) simultaneous voltages in phases *b* and *c* (d) all three voltages on a common time axis (e) phasor diagram.

variations of voltages of the three phases follow this pattern, the voltages are said to be of positive sequence and the phase ordering is positive phase sequence and it is denoted by *a b c* sequence. However, if the rotation of the rotor is reversed i.e. it is made to rotate clockwise the phase sequence would be *acb*. Here at first phase *a* attains its positive maximum value, next phase *c* and finally phase *b* attains its positive maximum and this is known as negative phase sequence.

Let us redraw the phasor diagram of the three phase voltages for the alternator of Fig. 3.3 when the phase voltages are expressed in their rms values. Let this diagram be as shown in Fig. 3.4(a).

Here the phasor voltages for the phases *a b* and *c* are V_{Na} , V_{Nb} and V_{Nc} respectively and these are known as phase voltages and usually denoted by V_{ph} or V_{ϕ} . If we take phase *a* voltage as the reference, the three phase voltages are expressed mathematically as

$$V_{Na} = V_{ph} \angle 0^\circ \quad V_{Nb} = V_{ph} \angle -120^\circ$$

$$\text{and} \quad V_{Nc} = V_{ph} \angle 120^\circ$$

The voltage between phases *a* and *b* is denoted as V_{ab} . Similarly, V_{bc} and V_{ca} are known as voltages between phases *b* and *c* & *c* and *a* respectively. These are known as line to line voltages or simply line voltage. Voltage V_{ab} is expressed as $V_{ab} = V_a - V_b$. Here $-V_b$ means the phasor Voltage V_b is reversed. This is illustrated in Fig. 3.4(b). Using law of parallelogram of forces where two sides are $|V_a| = |V_b| = |V_{ph}|$ and the angle between the two phasors is 60° .

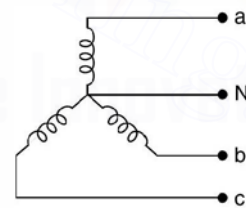

Fig. 3.3 Wye connection in a 3-phase alternator.

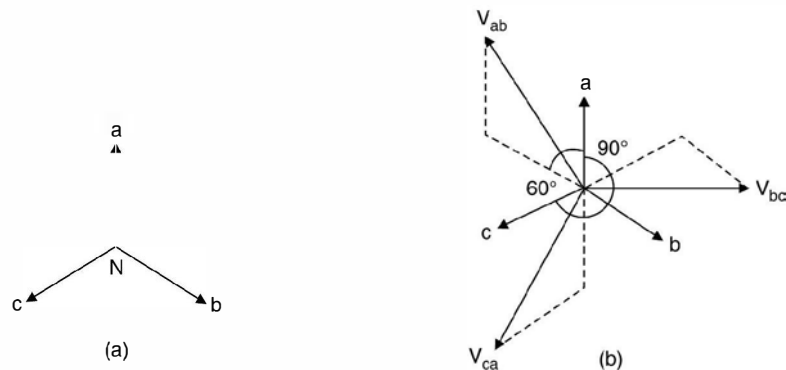

Fig. 3.4 (a) Three phase phasor diagram

(b) Line voltage phasor diagram.

Hence
$$|V_{ab}|^2 = V_{ph}^2 + V_{pn}^2 + 2 |V_{ph}| \cdot |V_{ph}| \cos 60^\circ$$

$$= 3 |V_{ph}|^2$$

or
$$|V_{ab}| = \sqrt{3} |V_{ph}| \quad \dots(3.1)$$

This means in a star connected system the line voltages equal $\sqrt{3}$ times the phase voltages.

Let us consider a star connected 3-phase supply system connected to a 3-phase star connected load as shown in Fig. 3.5. It can be seen that for star connected supply the line currents I_a , I_b and I_c are same as phase currents.

Therefore, we conclude that for a star connected system

$$V_L = \sqrt{3} V_{ph}$$

and

$$I_L = I_{ph}$$

For a balanced 3-phase supply the neutral N is always held at zero or ground potential. The common terminal of star connected load is known as star point rather than neutral.

The three-phase supply under normal conditions is balanced, however, the load need not necessarily be balanced. The load is said to be balanced when all the three arms of the load are identical. If the load is balanced the star point of the load is also at zero potential and if the star point and the neutral point of the supply are connected by a wire the current in this wire will be zero. However, if the load is unbalanced, the star point of the load is no more at zero potential and there will be a current, I_n in the wire connecting the star point and the neutral of the supply. This system is known as three-phase 4-wire system. Every effort is made by the electric utilities to maintain balanced load on the system, as unbalanced load on the system gives rise to what is known as negative sequence current which adversely affect the operation of the rotating machines in the system.

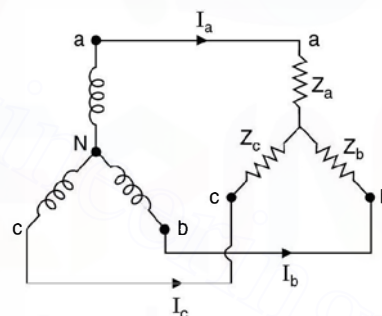

Fig. 3.5 Three phase star connected load across 3-phase Y connected supply.

The sum of the three phase voltages of a 3-phase balanced supply is zero.

$$\begin{aligned} V_a + V_b + V_c &= V_{ph} \angle 0 + V_{ph} \angle -120 + V_{ph} \angle 120^\circ \\ &= V_{ph} + (-0.5 - j 0.866) V_{ph} + (-0.5 + j 0.866) V_{ph} \\ &= 0 \end{aligned}$$

The three balanced phase voltages form a closed equilateral triangle and hence, this also shows that the sum of the three phase voltages is zero. Similarly, if a balanced load is connected across a balanced supply, the sum of three phase or line currents is again zero.

However, if the three phase load is unbalanced even though the star-point is not at zero potential, the sum of the three currents I_a , I_b and I_c is zero if it is a three-phase three wire system. For 3-phase 4 wire system for unbalanced load the sum of three phase currents equals neutral current $I_a + I_b + I_c = I_N$.

3.2 ANALYSIS OF STAR CIRCUITS

We will assume that the supply is star connected and balanced. However, the star connected load could be balanced or unbalanced.

If the load is balanced i.e. all the three star legs have identical impedances, in such a case, the circuit can be analysed based on 1-phase basis.

Consider Fig. 3.5. Here if $Z_a = Z_b = Z_c = Z$

then
$$I_a = \frac{E_a}{Z}, \quad \text{If } Z = |Z| \angle \phi$$

$$I_a = \frac{E_a \angle 0}{Z \angle \phi} = \frac{|E_a|}{|Z|} \angle -\phi$$

Similarly
$$I_b = \frac{E_b}{Z \angle \phi} = \frac{|E_b| \angle -120^\circ}{Z \angle \phi} = \frac{|E_b|}{|Z|} \angle -120 - \phi$$

and
$$I_c = \frac{|E_c| \angle 120}{Z \angle \phi} = \frac{|E_c|}{|Z|} \angle 120 - \phi$$

and these can be drawn on a phasor diagram as shown in Fig. 3.6.

It can be seen that the three phase current or in this case line currents are balanced and hence the resultant sum is zero. In a balanced system there is no need to connect the star point of load and neutral of the source.

However, if the load is unbalanced if $Z_a \neq Z_b \neq Z_c$, and even if two of the impedances are equal and the third one is different, it is still an unbalanced load and the analysis can be carried out using loop equations or by using Millman Theorem. Fig. 3.5 is reproduced here for convenience. Taking loop consisting of voltage sources E_a and E_b and the impedances Z_a and Z_b we have

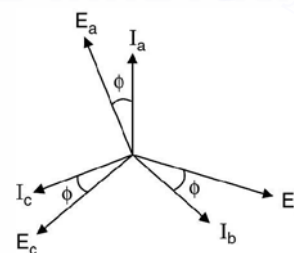

Fig. 3.6 Phasor diagram for a balanced lagging *p.f.* load.

$$E_a - I_a Z_a + I_b Z_b - E_b = 0 \quad \dots(3.2)$$

Similarly for the other loop this equation is

$$E_a - I_a Z_a + I_c Z_c - E_c = 0 \quad \dots(3.3)$$

and

$$I_a + I_b + I_c = 0 \quad \dots(3.4)$$

It is to be noted that all the quantities in these three equations viz. E_a , E_b , E_c , Z_a , Z_b and Z_c must be used in phasor form to obtain the solution for the currents I_a , I_b and I_c .

Millman Theorem: Since the load is unbalanced the star point of the load will not be at zero potential. Let the potential be V_s . This is given by Millman's Theorem as

$$V_s = \frac{\frac{E_a}{Z_a} + \frac{E_b}{Z_b} + \frac{E_c}{Z_c}}{\frac{1}{Z_a} + \frac{1}{Z_b} + \frac{1}{Z_c}} \quad \dots(3.5)$$

Again, all the quantities on the rhs are to be used in phasor form. Once V_s is known

$$I_a = \frac{E_a - V_s}{Z_a}, \quad I_b = \frac{E_b - V_s}{Z_b}$$

and

$$I_c = \frac{E_c - V_s}{Z_c}$$

Even though it is an unbalanced system, since the star point is not connected to the neutral of the supply, the sum of the three currents $I_a + I_b + I_c = 0$.

The potential of the star point is an indication of the degree of unbalancing of the load. The higher the value of V_s , the larger is the degree of unbalancing and hence it is an undesirable operation of the system.

Consider 3-phase 4-wire system as shown in Fig. 3.7.

Whenever 1-phase loads are present in the system, 3-phase 4-wire system is used. The distribution is, therefore, invariably a 3-phase 4-wire system.

The analysis here again is on single phase basis

$$I_a = \frac{E_a \angle 0^\circ}{Z_a}, \quad I_b = \frac{E_b \angle -120^\circ}{Z_b}$$

$$I_c = \frac{E_c \angle 120^\circ}{Z_c}$$

and

$$I_a + I_b + I_c = I_n$$

Here Z_a , Z_b and Z_c may include the impedance of the leads between the alternator and the load and between the star point and the neutral of the alternator if these are present.

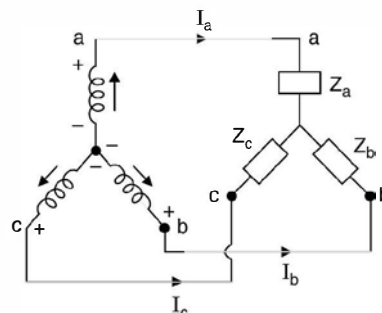

Fig. 3.6(a) Unbalanced loading.

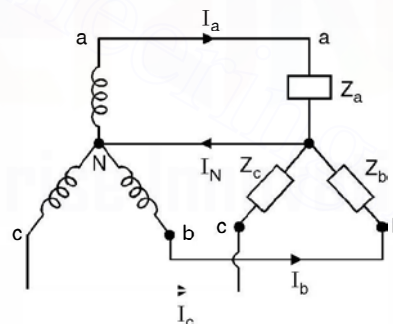

Fig. 3.7 3-phase 4-wire system.

It is to be noted that whenever, in a problem, system voltage is specified, it is always to be taken as line voltage or line to line voltage, unless it is specified as phase voltage.

Let us take a few examples to illustrate what we have learnt so far.

Example 3.1. A balanced 3-phase star connected load is fed from a 208 volt 3-phase supply. Each leg of the load has a resistance of 35Ω . Determine, the power factor, the total power, the phase currents and line currents of the system.

Solution: Since it is a balanced circuit, the analysis is to be made on 1-phase basis. Also the given voltage 208 since not specified, it is to be taken as line voltage.

Hence phase voltage is $208/\sqrt{3} = 120$ volt.

$$I_a = \frac{120 \angle 0}{35} = 3.428 \angle 0^\circ$$

$$I_b = \frac{120 \angle -120}{35} = 3.428 \angle -120^\circ$$

$$I_c = \frac{120 \angle 120}{35} = 3.428 \angle 120^\circ$$

Since the three currents are balanced, the phasor sum of the three currents is zero. Since the load is resistive power p per phase is

$$I^2 R = 3.428^2 \times 35 = 411.3 \text{ watts}$$

Hence total power $3 \times 411.3 \approx 1234$ watts and the load is resistive, the p.f. is unity. Since the load is star connected $I_L = I_{ph} = 3.428$ A.

Example 3.2. Repeat example 3.1 if each leg of the load has an impedance of $(15 + j20)\Omega$.

Solution: Again as it is balanced load we analyse it on 1-phase basis.

$$\begin{aligned} \text{Impedance } z &= |z| \angle \phi = \sqrt{15^2 + 20^2} \tan^{-1} \frac{20}{15} \\ &= 25 \angle 53^\circ \end{aligned}$$

$$\text{Hence } I_a = \frac{120 \angle -0}{25 \angle 53^\circ} = 4.8 \angle -53^\circ$$

$$I_b = \frac{120 \angle -120}{25 \angle 53^\circ} = 4.8 \angle -173^\circ$$

$$I_c = \frac{120 \angle 120}{25 \angle 53^\circ} = 4.8 \angle 67^\circ$$

Now power can be calculated either using the formula, power loss = $3I^2R$

$$\begin{aligned} \text{or } P &= 3V_{ph} I_{ph} \cos \phi \\ &= \sqrt{3} V_L I_L \cos \phi \end{aligned}$$

Using the ohmic loss formula, since resistance in each phase is 15Ω , the power loss is $3 \times 4.8^2 \times 15 = 1036.8$ watts.

In the formulae $P = \sqrt{3} V_L I_L \cos \phi$, the angle ϕ is the angle between the phase voltage and the phase current corresponding to the same phase. It is to be noted with caution that the angle ϕ is not the angle between the line voltage and line current or phase current but it is the

angle between phase voltage and phase current. Since the impedance angle is 53° it is an inductive load and the current in each phase lags by its voltage by 53° .

$$\begin{aligned} \text{Hence} \quad P &= \sqrt{3} \times 208 \times 4.8 \cos 53^\circ \\ &= 1037 \text{ watts. Ans.} \\ I_L &= I_{ph} = 4.8 \text{ A} \end{aligned}$$

Example 3.3. A symmetrical 3-phase 440 volt system supplies a star connected load. The branch impedances are $Z_R = 10 \angle 30^\circ$, $Z_Y = 12 \angle 45^\circ$ and $Z_B = 15 \angle 40^\circ$. Assuming the neutral of the supply to be earthed, calculate the potential of the star point and the line currents, phase sequence R Y B.

Solution: Using Millman Theorem

$$\begin{aligned} V_s &= \frac{\frac{254 \angle 0}{10 \angle 30} + \frac{254 \angle -120}{12 \angle 45^\circ} + \frac{254 \angle 120^\circ}{15 \angle 40}}{0.1 \angle -30 + \frac{1}{12} \angle -45^\circ + \frac{1}{15} \angle -40} \\ &= \frac{25.4 \angle -30^\circ + 21.17 \angle -165 + 16.9 \angle 80}{0.0866 - j0.05 + 0.0589 - j0.0589 + 0.05 - j0.0428} \\ &= \frac{21.996 - j 12.702 - 20.45 - j 5.48 + 2.94 + j 16.68}{0.1966 - j 0.152} \\ &= \frac{4.73 \angle -18.5}{0.2485 \angle -37.71} \\ &= 19.03 \angle 19.21 \\ I_a &= \frac{254 \angle 0 - 19.03 \angle 19.21}{10 \angle 30} \\ &= \frac{236.1 \angle -15}{10 \angle 30} \\ I_a &= 23.61 \angle -31.5 \\ I_b &= \frac{254 \angle -120 - 19.03 \angle 19.21}{12 \angle 45^\circ} \\ &= \frac{-127 - j 219.96 - 17.97 - j 6.26}{12 \angle 45^\circ} \\ &= \frac{268.68 \angle -122.7}{12 \angle 45^\circ} \\ &= 22.39 \angle -167.7 \\ I_c &= \frac{254 \angle 120 - 19.03 \angle 19.21}{15 \angle 40} \\ &= \frac{-144.97 + j 213.70}{15 \angle 40} = \frac{258.2 \angle +124.2}{15 \angle 40} \\ &= 17.21 \angle 84.2 \\ I_a + I_b + I_c &= 23.61 \angle -31.5 + 22.39 \angle -167.7 + 17.21 \angle 84.2 \\ &= 20.13 - j 12.336 - 21.87 - j 4.77 + 1.74 + j 17.12 \\ &= 21.87 - 21.87 - j 17.10 + j 17.12 = 0 \end{aligned}$$

Hence it is found that for a 3-phase 3 wire system with unbalanced loading the sum of the three currents is zero (KCL at star point).

Example 3.4. Three equal star-connected inductors take 8 KW at p.f. 0.8 when connected to a 460 volt 3 – phase 3-wire supply. Determine line currents if one inductor is short circuited.

Solution. Refer to Fig. E 3.4 (a) and (b).

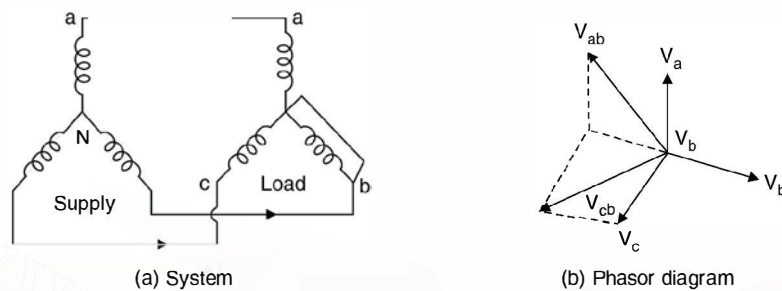

Fig. E 3.4

Suppose inductor in phase b is shorted. Therefore, the voltage across inductor in phase a is $V_a - V_b$ as the potential of the star point equals V_b . Similarly voltage across the inductor in phase c is

$$V_{cb} = V_c - V_b$$

These voltages have been shown in the phasor diagram. We take here V_{ab} as the reference.

Now the phase current

$$= \frac{8 \times 1000}{\sqrt{3} \times 460 \times 0.8} = 12.55 \text{ A}$$

Hence impedance per phase

$$= \frac{V_{ph}}{I_{ph}} = \frac{460}{\sqrt{3} \times 12.55} = 21.16 \Omega$$

Hence

$$Z = 21.16 (0.8 + j 0.6) \\ = 16.93 + j 12.7 = 21.16 \angle 36.86$$

$$\text{Current in phase } a = \frac{460 \angle 0}{21.16 \angle 36.86} = 21.7 \angle -36.8$$

$$\text{Current in phase } c = \frac{460 \angle 60}{21.16 \angle 36.86} = 21.7 \angle 23.14$$

I_a and I_c are at an angle of $60^\circ = (23.14^\circ + 36.86^\circ)$

Hence

$$I_b^2 = I_a^2 + I_c^2 + 2I_a I_c \cos 60^\circ \\ = 21.7^2 + 21.7^2 + 2 \times 21.7 \times 21.7 \times \frac{1}{2} \\ = 3 \times 21.7^2 = 37.6 \text{ Amp.}$$

3.3 DELTA CIRCUITS

Each coil has two terminals, start and finish terminal. Fig. 3.8 shows that winding terminals $a' b' c'$ are called the start terminals whereas abc the finish terminals.

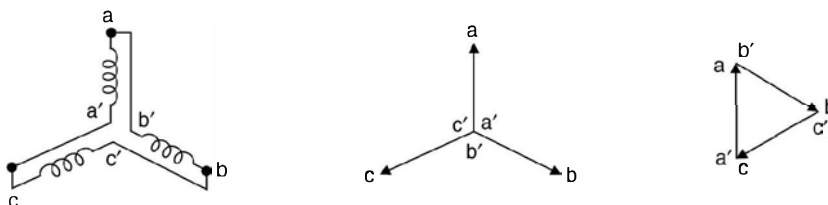

Fig. 3.8 (a) Delta (b) Star phasor (c) delta phasor.

If the start point represents the tail of the phasor and the finish point the arrow head of the phasor, when $a' b' c'$ are joined together forming the neutral of the system, a, b, c form the phase terminals of the system.

However, if the finish of phase a is connected to start of phase $b(b')$ and finish of phase b is connected to the start of phase $c(c')$ and finally the finish of phase c is connected to start of phase a , a closed circuit is formed and if the phasors are also drawn on these lines, a Δ like shape is obtained. This is known as delta circuit. In the phasors diagram of Fig. 3.8(c), the finish of phasor a (arrow head of phase a) is connected to start of phase b (tail of arrow of phase b).

From Fig. 3.8 (a) and (c) it is seen that there is no common terminal for all the three windings and hence delta winding does not have a neutral.

To find out relation between line quantities and phase quantities for a delta connected system refer to Fig. 3.9

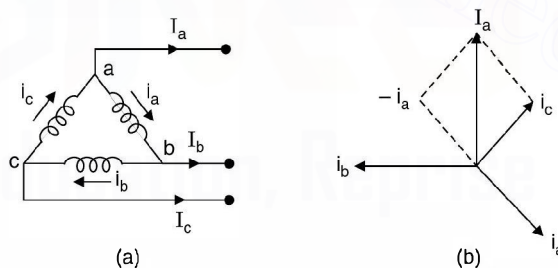

Fig. 3.9 Line, phase relations.

From the Fig. 3.9 it is clear that the phase voltage equals the line voltage *i.e.* line voltage V_{ab} is also the phase voltage of phase (a).

Now to find out relation between line current and phase current, we apply *KCL* at node a of Fig. 3.9(a)

$$I_a + i_a - i_c = 0$$

or

$$I_a = i_c - i_a$$

Assuming of course balanced system $|i_a| = |i_b| = |i_c| = i_{ph}$ and referring to phasor diagram of Fig. 3.9(b) it is seen that $I_a = i_c - i_a = \sqrt{3} i_{ph}$ *i.e.* the line current is $\sqrt{3}$ times the phase current.

Normally the supply is star connected as neutral is available, hence single phase loads can be supplied. Also, for the same line voltage, the star winding requires less insulation as the insulation is to be provided for $\frac{V_L}{\sqrt{3}}$ voltage as against delta connection, where the insulation per phase is V_L .

We have already studied the analysis when supply is star connected and the load is also star connected under various options.

In case the load is delta connected whether balanced or unbalanced, the analysis is to be made on individual phase basis. The following example will further illustrate the solution of delta connected circuits.

Example 3.5. A balanced delta connected load of $(8 + j6) \Omega$ per phase is connected to a 3-phase 230 V supply. Find the line current, p.f., power, reactive power and total volt amperes.

Solution. Since it is a balanced system the phase current

$$i_R = \frac{230 \angle 0}{8 + j6} = 23 \angle -36.8 \text{ i.e. the p.f. is } 0.8$$

$$\text{Line current} \quad 23 \sqrt{3} = 39.8 \text{ A}$$

$$\begin{aligned} \text{Power} \quad \sqrt{3} V_L I_L \cos \phi &= \sqrt{3} \times 230 \times 39.8 \times 0.8 \\ &= 12.696 \text{ kw} \end{aligned}$$

$$\begin{aligned} \text{Reactive power } \sqrt{3} V_L I_L \sin \phi &= \sqrt{3} \times 230 \times 39.8 \times 0.6 \\ &= 9.513 \text{ KVAr} \end{aligned}$$

$$\text{and} \quad \text{Total KVA} = \sqrt{3} \times 230 \times 39.8 = 15.855 \text{ KVA Ans.}$$

Example 3.6. A 400 v, 50 Hz 3-phase supply has 100 ohm between R and Y, $j 100 \Omega$ between Y and B and $-j 100 \Omega$ between B and R. Find (a) line currents for phase sequence RYB (b) star connected balanced resistors for the same power.

Solution: Phase sequence RYB

$$\begin{aligned} I_{RY} &= \frac{400 \angle 0}{100} = 4 \angle 0 \\ I_{YB} &= \frac{400 \angle -120}{j 100} = 4 \angle -210 \\ I_{BR} &= \frac{400 \angle 120}{-j 100} = 4 \angle 210 \\ I_R &= I_{RY} - I_{BR} \\ &= 4 - 4 \angle 210 \\ &= 4 + 3.46 + j2 \\ &= 7.46 + j2 \\ &= 7.72 \angle 14.5 \\ I_Y &= I_{YB} - I_{RY} \\ &= 4 \angle -210 - 4 \end{aligned}$$

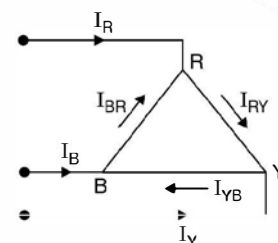

Fig. E 3.6

$$\begin{aligned}
 &= -3.46 + j2 - 4 \\
 &= -7.46 + j2 \\
 &= 7.72 \angle 165
 \end{aligned}$$

Similarly

$$\begin{aligned}
 I_B &= I_{BR} - I_{YB} \\
 &= 4 \angle 210 - 4 \angle -210 \\
 &= -3.46 - j2 + 3.46 - j2 \\
 &= -j2 = 2 \angle -90^\circ
 \end{aligned}$$

(b) Since power consumed is only in the arm RY where the current is 4 A. Total power $4^2 \times 100 = 1600$ watts.

If the resistors are connected in star, voltage across each star leg is $400/\sqrt{3}$ and if R is the resistance per star leg, total power

$$\begin{aligned}
 3 \times \left(\frac{400}{\sqrt{3}} \right)^2 \cdot \frac{1}{R} &= 1600 \\
 \frac{16 \times 10^4}{R} &= 1600 \quad \text{or} \quad R = 100 \Omega.
 \end{aligned}$$

Example 3.7. A 3-phase 3-wire supply feeds a load consisting of 3 equal resistors. By how much is the load reduced if one of the resistors be removed (a) when the load is star connected (b) when the load is mesh connected ?

Solution: (a) Star connected load.

Let R be the resistance per phase and V_{ph} is the phase voltage.

$$\text{The power 3 phase} = 3 \frac{V_{ph}^2}{R}$$

However, if one of the resistors is removed the voltage across the remaining two resistors is $V_L = \sqrt{3} V_{ph}$. Hence power drawn by the load = $\frac{(\sqrt{3} V_{ph})^2}{2R}$

$$= \frac{3V_{ph}^2}{2R}$$

Comparing the two results, the power under the second condition is just $\frac{1}{2}$ of the original power. Hence there is reduction of load by 50%.

(b) Mesh Connected load

Since it is mesh connected load, the voltage across each resistor is $V_L = \sqrt{3} V_{ph}$. Hence 3-phase power = $3 (\sqrt{3} V_{ph})^2 \cdot \frac{1}{R} = 3 \times 3 \frac{V_{ph}^2}{R}$. Comparing this result with the star connected load, it is found that for the same system voltage (Normally star connected), and same value of resistance if it is desired to have more power, the resistances should be connected in delta as then the power is three times what we have when these are connected in star.

Now if one of the resistors from delta connected load is removed, the voltage across each resistor is still line voltage hence, power drawn.

$$2 \cdot (\sqrt{3} V_{ph})^2 \cdot \frac{1}{R} = \frac{2 \times 3 V_{ph}^2}{R}$$

The difference in power is $\frac{3V_{ph}^2}{R}$ which is 33.3% of the original power.

Similarly, if capacitors are to be connected in the circuit for supplying reactive power to the system, for the same capacitance, it is desirable to connect them in delta for higher reactive power supply.

3.4 MEASUREMENT OF POWER IN 3-PHASE CIRCUITS

We first study measurement of active power

The following are the methods.

1. Three wattmeter method → Both balanced and unbalanced loads.
2. Two wattmeter method → Both balanced and unbalanced loads.
3. One wattmeter method → for balanced loads only.

3.4.1 Three Wattmeter Method

Fig. 3.10 shows the connection of the three wattmeters to a star connected load. These three wattmeters could be three single phase wattmeters or a single unit consisting of three wattmeteric elements.

The arrows in the diagram show the direction of current and voltage which are conventionally considered positive. If the letters representing currents and voltages denote instantaneous values then, instantaneous power in the load,

$$= e_1 i_1 + e_2 i_2 + e_3 i_3$$

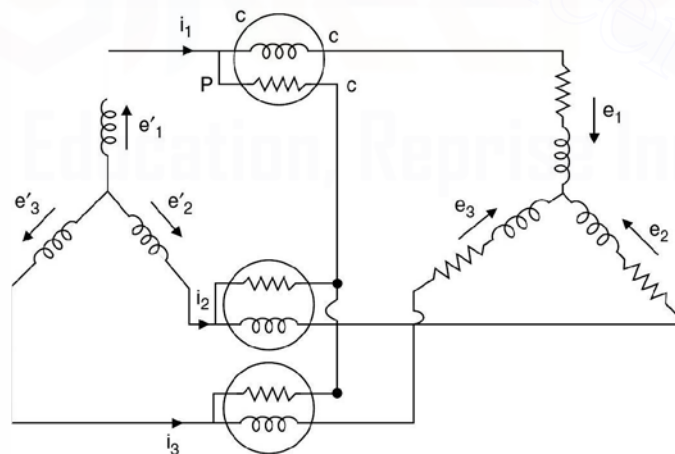

Fig. 3.10 Three wattmeter method for power measurement.

If it is an unbalanced load the potential of the star point is v , therefore,

$$e_1 = e_1' + v$$

$$e_2 = e_2' + v$$

and

$$e_3 = e_3' + v$$

Therefore, instantaneous power of the load,

$$\begin{aligned} &= (e_1' + v)i_1 + (e_2' + v)i_2 + (e_3' + v)i_3 \\ &= e_1'i_1 + e_2'i_2 + e_3'i_3 + v(i_1 + i_2 + i_3) \\ &= e_1'i_1 + e_2'i_2 + e_3'i_3 \end{aligned}$$

as $i_1 + i_2 + i_3 = 0$ for a star connected load

whether it is balanced or unbalanced.

Now $e_1'i_1 + e_2'i_2 + e_3'i_3$ is the total instantaneous power measured by the three wattmeters and thus the sum of the readings of the wattmeter will give the mean value of the total power.

3.4.2 Two Wattmeter Method

Fig 3.11 shows two wattmeter method of measurement of power. This is the most commonly used method for measurement of power as this can be used both for balanced and unbalanced load and requires two wattmeters.

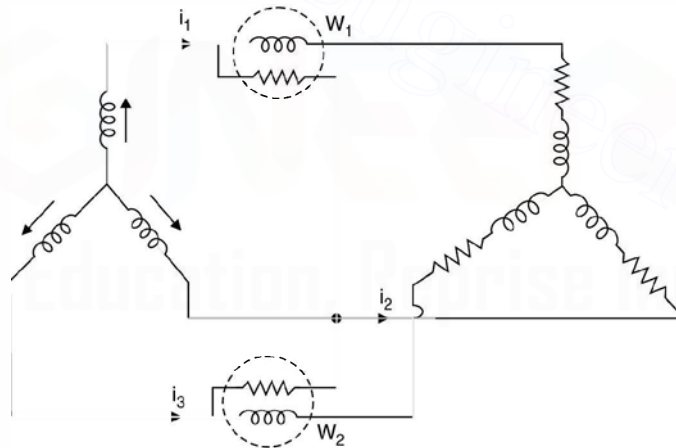

Fig. 3.11 Two-wattmeter method of measuring 3-phase power.

The voltage across the pressure coil of W_1 is $(e_1 - e_2)$ and the current i_1 whereas voltage across the pressure coil of W_2 , the voltage is $(e_3 - e_2)$ and the current i_3 . Hence, instantaneous power recorded by the two wattmeters.

$$\begin{aligned}
 &= (e_1 - e_2) i_1 + (e_3 - e_2) i_3 \\
 &= e_1 i_1 + e_3 i_3 - e_2 (i_1 + i_3) \\
 &= e_1 i_1 + e_3 i_3 + e_2 i_2
 \end{aligned}$$

as $i_1 + i_3 = -i_2$

Hence the two wattmeters connected in this fashion i.e. current coil in phase 1 and 3 and potential coils between phase 1 and 2 & 3 and 2, measures instantaneous 3-phase power.

However, if the load is balanced, the following analysis can be used to calculate the p.f. of the balanced load.

Fig. 3.12 shows the phasor diagram for the connections of Fig. 3.11 for balanced loads. Phasors have been drawn taking rms values into considerations.

$$\text{Power } W = W_1 + W_2 = E_{12} I_1 \cos(30 + \phi) + E_{32} I_3 \cos(30 - \phi)$$

Since it is a balanced circuit,

$$|E_{12}| = |E_{32}| = \sqrt{3} |E_{ph}|$$

and

$$|I_1| = |I_3| = |I| \quad (\text{say})$$

Therefore,

$$\begin{aligned}
 W &= \sqrt{3} E_{ph} I \cos(30 + \phi) + \sqrt{3} E_{ph} I \cos(30 - \phi) \\
 &= \sqrt{3} E_{ph} I [\cos(30 + \phi) + \cos(30 - \phi)] \\
 &= 2\sqrt{3} E_{ph} I \cos 30 \cdot \cos \phi \\
 &= 3 E_{ph} I \cos \phi
 \end{aligned}$$

Which is nothing but the three phase power in the balanced load.

It can be seen that if the p.f. of the load is 0.5 i.e. $\phi = 60^\circ$ the reading of W_1 becomes zero and if the p.f. is less than 0.5, the p.f. angle is greater than 60° and with the usual connection of the wattmeter W_1 will read negative and hence the connection of either the current coil or the pressure coil should be reversed to obtain its reading and in such a situation this reading is to be reckoned negative and the total power consumed by the load is the algebraic sum of the two wattmeter readings.

Now to find out p.f. we obtain $W_1 - W_2$

$$\begin{aligned}
 &= \sqrt{3} E_{ph} I [\cos(30 + \phi) - \cos(30 - \phi)] \\
 &= \sqrt{3} E_{ph} I [-2 \sin \phi \sin 30^\circ]
 \end{aligned}$$

or $W_2 - W_1 = \sqrt{3} E_{ph} I \cdot 2 \cdot \frac{1}{2} \sin \phi = \sqrt{3} E_{ph} I \sin \phi$

Hence $\frac{W_2 - W_1}{W_2 + W_1} = \frac{\sin \phi}{\sqrt{3} \cos \phi} = \frac{\tan \phi}{\sqrt{3}}$

or $\tan \phi = \frac{\sqrt{3} (W_2 - W_1)}{W_2 + W_1}$

Hence $\cos \phi$, the p.f. of the load can be calculated.

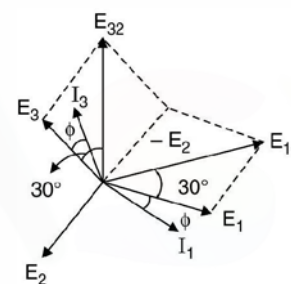

Fig. 3.12 Phasor diagram for Fig. 3.11.

3.4.3 One Wattmeter Method

This method can be used when the load is balanced. Fig. 3.13 shows connection for a star connected balanced load. Current coil of the wattmeter is connected in one of the lines (say '1') and one terminal of the pressure coil is connected to line 1 and the other terminal to line 2 and 3 alternatively for the two readings of the wattmeter using the switch as shown in the Fig. 3.13.

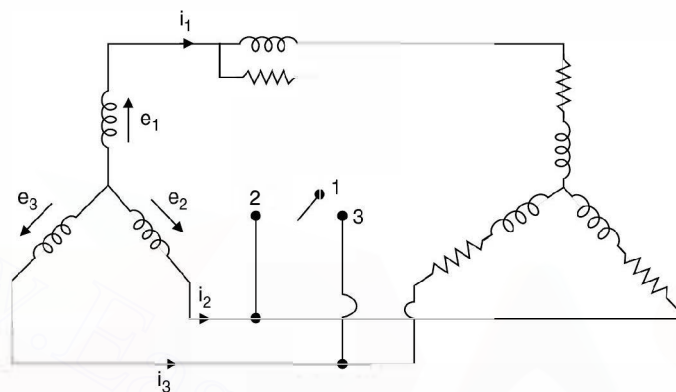

Fig. 3.13 One wattmeter method.

The two wattmeter readings are obtained first by connecting to terminal 2 and then to terminal 3. The two readings are

$$\begin{aligned} &= (e_1 - e_2) i_1 + (e_1 - e_3) i_1 \\ &= e_1 i_1 + e_1 i_1 - (e_2 + e_3) i_1 \\ &= 3e_1 i_1 \end{aligned}$$

as $e_1 + e_2 + e_3 = 0$

Since it is a balanced load, this gives the average instantaneous power measured by the wattmeter.

To obtain p.f. of the load, refer to phasor diagram Fig. 3.14.

The wattmeter readings are

$$\begin{aligned} W &= \sqrt{3} E_{ph} I \cos (30 - \phi) + \sqrt{3} E_{ph} I \cos (30 + \phi) \\ &= W_2 + W_1 \end{aligned}$$

First term is when switch is connected to terminal 3 and the second term when it is connected to terminal 2.

This is similar to the two wattmeter method and

$$\tan \phi = \frac{\sqrt{3} (W_2 - W_1)}{W_2 + W_1}$$

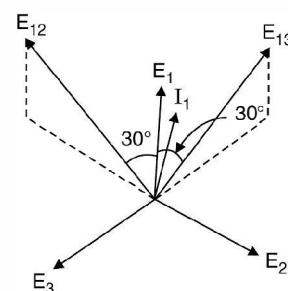

Fig. 3.14. Phasor diagram to Fig. 3.13.

3.5 MEASUREMENT OF REACTIVE POWER

If three phase power and the p.f. of the circuit are known reactive power = $W \tan \phi$. However, Fig. 3.15 gives connection for reactive power measurement using one wattmeter when the load is balanced. Here current coil of the wattmeter is connected in one line and the pressure coil is connected across the other two lines.

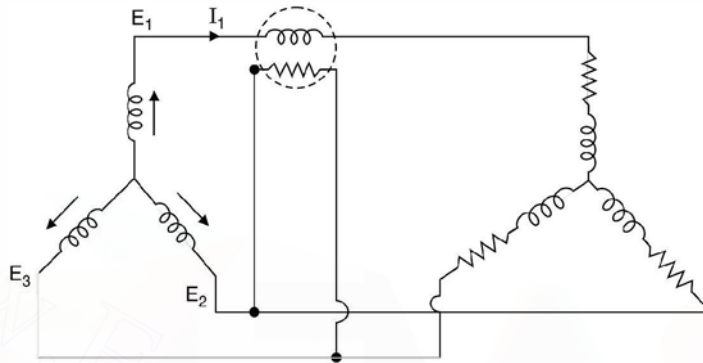

Fig. 3.15 Reactive power measurement.

Fig. 3.16 shows the phasor diagram for the system in Fig. 3.15.

The wattmeter reading is

$$\begin{aligned} & \sqrt{3} E_{ph} I \cos (90 - \phi) \\ & = \sqrt{3} E_{ph} I \sin \phi \end{aligned}$$

which is the reactive power $\sqrt{3}$ times per phase, the wattmeter can be so calibrated that it indicates three phase reactive power by having a multiplication factor of $\sqrt{3}$.

Example 3.7. Find the reading of the wattmeter when the network shown is connected to symmetrical 440 V, 3- ϕ supply. Phase sequence R Y B.

Solution: Taking E_{RY} as reference

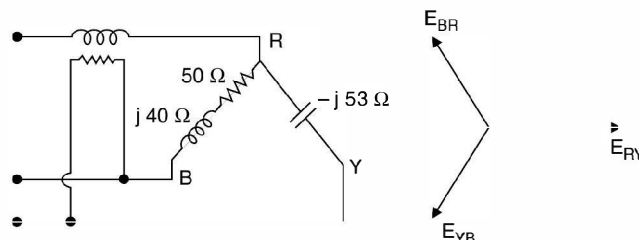

Fig. E3.7

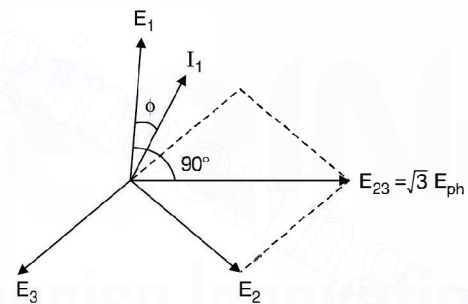

Fig. 3.16 Phasor diagram for Fig. 3.15.

$$I_{RY} = \frac{440 \angle 0}{-j53} = 8.3 \angle 90$$

$$I_{BR} = \frac{440 \angle 120}{50 + j40} = \frac{440 \angle 120}{64 \angle 38.6} \\ = 6.875 \angle 81.4$$

$$I_R = I_{RY} - I_{BR} = 8.3 \angle 90 - 6.875 \angle 81.4 \\ = j8.3 - 1.03 - j6.8 = -1.03 + j1.5$$

Power

$$P = \text{Re}[VI^*] = \text{Re}[E_{YB} I_R^*] \\ = \text{Re}[(-220 - j381)(-1.03 - j1.5)] \\ = 226.6 - 571 = -344.4 \text{ W} \quad \text{Ans.}$$

Example 3.8. A 500 volt 3-phase motor has an output of 37.3 KW and operates at a p.f. of 0.85 with an efficiency of 90%. Calculate the reading on each of the two wattmeters connected to measure the input.

Solution:

The input $\frac{37.3}{0.9} = 41.44 \text{ KW}$

Now $W_1 + W_2 = 41.44 \text{ KW}$

$$\tan \phi = \frac{\sqrt{3}(W_2 - W_1)}{W_2 + W_1} = 0.6197 \\ = \frac{\sqrt{3}(W_2 - W_1)}{41.44}$$

or $W_2 - W_1 = 14.82$

$$W_1 + W_2 = 41.44$$

$$2W_2 = 56.26 \quad \text{or} \quad W_2 = 28.13 \text{ KW}$$

and $W_1 = 13.31 \text{ KW} \quad \text{Ans.}$

Example 3.9. Three nonreactive resistances are connected across a symmetrical 3-phase 400 volt system as shown in Fig. E 3.9. Determine current in each line, the total power input to circuit and the reading on each of the wattmeters. Phase sequence RYB.

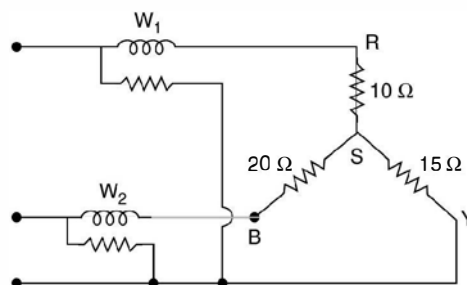
**Fig. E3.9.**

Solution: Taking V_R as reference, the potential of the star point.

$$V_S = \frac{231}{-10} + \frac{231 \angle -120}{15} + \frac{231 \angle 120}{20}$$

$$= \frac{1}{\frac{1}{10} + \frac{1}{15} + \frac{1}{20}}$$

$$= 44.39 - j15.36$$

$$I_R = \frac{V_R - V_S}{10} = \frac{231 - 44.39 + j15.36}{10}$$

$$= 18.66 + j1.5 \approx 18.7 \text{ A}$$

$$I_Y = \frac{231 \angle -120 - V_S}{15}$$

$$= \frac{115.5 - j200 - 44.39 + j15.36}{15}$$

$$= \frac{71.1 - j184.64}{15}$$

$$= 4.7 - j12.3 = 13.2 \text{ A}$$

$$I_B = \frac{231 \angle 120 - V_S}{20} = \frac{-115.5 + j200 - 44.39 + j15.36}{20}$$

$$= \frac{-159.89 + j215.36}{20}$$

$$= -7.99 + j10.77 = 13.4 \text{ Amp.}$$

Voltage across pressure coil

$$V_{RY} = V_R - V_Y = \sqrt{3} V_{ph} \angle 30^\circ$$

Hence power in wattmeter W_1 $Re [V I^*]$

$$= Re [\sqrt{3} (200 + j115.5) (18.66 - j1.5)]$$

$$= 6.76 \text{ KW}$$

$$V_{BY} = \sqrt{3} V_{ph} \angle 90^\circ$$

$$W_2 = Re [j400 (-7.99 - j10.77)]$$

$$= 4.3 \text{ KW}$$

Hence total power 11.06 KW Ans.

Example 3.10. Determine for the 250 V delta connected unbalanced 3-phase system shown (i) the current in each branch (ii) the current in each line and the reading of each wattmeter.

$$I_{RY} = \frac{250 \angle 0}{10 + j10} = 17.6 \angle -45^\circ$$

$$I_{YB} = \frac{250 \angle -120}{20 - j15} = 10 \angle -83.2$$

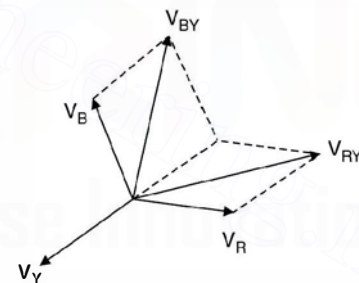

Fig. E3.9.1

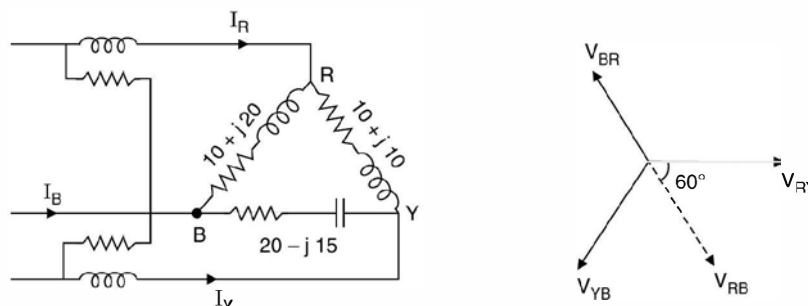

Fig. E3.10. (a) and (b)

$$I_{BR} = \frac{250 \angle 120}{10 + j20} = \frac{250 \angle 120}{22.36 \angle 63.4} = 11.18 \angle 56.6$$

$$\begin{aligned} I_R &= I_{RY} - I_{BR} = 17.6 \angle -45^\circ - 11.18 \angle 56.6 \\ &= 12.44 - j12.44 - 6.15 - j9.33 \\ &= 6.29 - j21.77 \\ &= 22.66 \text{ A} \end{aligned}$$

$$\begin{aligned} I_Y &= I_{YB} - I_{RY} \\ &= 10 \angle -83.2 - 17.6 \angle -45^\circ \\ &= 1.18 - j9.92 - 12.44 + j12.44 \\ &= -11.26 + j2.52 = 11.53 \text{ Amp} \end{aligned}$$

$$\begin{aligned} W_1 &= \text{Re}[VI^*] = \text{Re}[250 \angle -60 I_R^*] \\ &= \text{Re}[(125 - j216.5)(6.29 + j21.77)] \\ &= 787 + 4713 = 5500 \text{ Watts} \end{aligned}$$

$$\begin{aligned} W_2 &= \text{Re}[250 \angle -120 (-11.26 - j2.52)] \\ &= 862 \text{ Watts.} \end{aligned}$$

PROBLEMS

- 3.1. The power input to a 2000 V, 50 Hz 3-phase induction motor, running on full load at an efficiency of 90% is measured by two-wattmeters which indicate 300 kW and 100 kW respectively. Calculate (a) the input (b) the p.f. (c) the line current, (d) kW output.
[Ans. 400 kW, 0.76, 152, 360 kW]
- 3.2. Three non-reactive resistors of 3, 4 and 5 Ω respectively are star connected to a 3-phase 400 V symmetrical system, phase sequence RYB. Determine (a) current in each resistor (b) the power dissipated in each resistor (c) the phase angle between the currents and the corresponding line voltages (d) the star point voltage.
[Ans. (a) 66.5, 59.5, 51.8 A (b) 13.2, 14.15, 13.4 kW (c) 26°24', 38°10', 25° 20' (d) 34 V]
- 3.3. The currents in the RY, YB and BR branches of a delta connected system with symmetrical voltage are 25A at p.f. 0.8 lag 30 A at p.f. 0.7 lead and 20 A at unity p.f. respectively. Determine the currents in each line, phase sequence RYB.
[Ans. $I_R = 44.1$, $I_Y = 18.3$ A, $I_B = 49.5$ A]

- 3.4. The power input to a load was measured by two wattmeter method. The readings were 800 W and 400 W, the latter reading being obtained after reversing the potential coil connections. Find power and p.f. of the load. [Ans. 400 W, 0.189]
- 3.5. Prove that the power in a balanced 3-phase circuit can be measured from the readings of two wattmeters. Draw the relevant connection and phasor diagrams. If the readings on two wattmeters so connected are 5 KW and 0.5 KW, the latter reading being obtained after reversal of the current coil connections. Calculate the power and p.f. of the load. Show how the wattmeters are connected to measure the reactive power in a circuit. [Ans. 4.5 kW, 0.426]
- 3.6. A load of impedances each $9 + j21$ is supplied through a line to which a voltage of 415 V is applied. The impedance of each line is $2 + j4\Omega$. Determine the power input and output when the load is (a) star connected (b) mesh connected. [Ans. (a) 2556, 2091W (b) 5925, 3555.]

www.EasyEngineering.net

ENGINEERING

© Apprise Education, Reprise Innovations ©

CHAPTER

4

Basic Instruments

4.1 INTRODUCTION

Ammeters and voltmeters are classified together as there is no difference in the principle for torque production. A voltmeter carries a current proportional to the voltage which produces operating torque whereas in case of an ammeter, the torque is produced by the current to be measured or by a definite fraction of it.

The basic philosophy of measurement is that whenever we insert an instrument for measurement of certain quantity, its insertion should not disturb the corresponding already existing quantity in the network.

An ammeter is used to measure current in a circuit and hence it is to be connected in series with the circuit. Now if there is certain current in the circuit, the insertion of ammeter in the circuit should not disturb the current value. This requires that the ammeter must have low resistance. Similarly, a voltmeter is connected across the voltage to be measured and must, therefore, have a high resistance so that the current taken by it should be small. A low range ammeter *i.e.* the one which can measure small values of current can be used as a voltmeter by connecting a high resistance in series with it. Of course, the current through the converted voltmeter should not exceed its range when used as an ammeter.

It is to be noted that torque in an a.c. instrument can be produced only when there are two fluxes displaced in time and space. If an ammeter or a voltmeter whose operating torque is proportional to the current passing through it, will produce a pulsating torque if used in ac circuits and hence the inertia of the moving system of the instrument will not be able to respond to the pulsating torque and hence no deflection would be observed.

It is, therefore, essential that while measuring a.c. quantities, the torque should be proportional to the square of the current passing through the instrument. The deflection would then be proportional to the mean value of the square of current (assuming spring control is used) and the instrument can thus be used for the measurement of rms values of current or voltage.

4.2 TYPES OF INSTRUMENTS

The following types of ammeters and voltmeters are in common use :

(a) Moving coil

- (i) Permanent magnet form
- (ii) Dynamometer form
- (b) Moving iron
- (c) Hot wire
- (d) Electrostatic (voltmeters only)
- (e) Induction.

Here we will concentrate mainly on moving coil and moving iron types whereas a brief introduction for the others will be given.

Of the above mentioned, the permanent magnet moving coil is used for dc only whereas induction type are used for ac measurement. The other types can be used both for dc as well as ac circuits.

4.2.1 Permanent Magnet Moving Coil Type

The basic principle of operation is that when a current carrying conductor is brought in a magnetic field (they should not be parallel to each other) a torque on the conductor is produced. The instrument consists of a rectangular coil pivoted so that its sides lie in the air gap between the two poles of a permanent magnet and a soft-iron cylinder. The air gap between the magnet poles and iron core is small and the flux density is uniform and is in a radial direction, so that the flux lines are always at right angle to the current carrying conductor and hence when current passes through the coil, a deflecting torque is produced owing to the interaction between the two fluxes, one due to permanent magnet and the other due to the magnetic field of the coil. This is shown in Fig. 4.1.

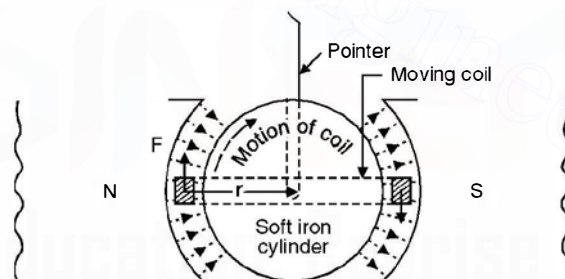

Fig. 4.1. Action of permanent-magnet moving-coil instrument.

If I is the current flowing in the moving coil in the direction shown, forces F , F will act on the two sides of this coil, the direction of force being determined by Fleming's left-hand rule and is in the direction for this system as shown in Fig. 4.1. The torque causing the coil to rotate is given as $F \cdot 2r$ where r is the mean distance of the wires forming the sides of the coil, from the axis of rotation.

Now, if N is the no. of turns in the coil, B the magnetic flux density due to permanent magnet, I the current in the coil, l the effective length, the force acting on the coil is given by

$$F = NBIl \quad \text{Newton} \quad \dots(4.1)$$

Hence the torque on the coil is

$$T = NBIl \cdot 2r \quad \text{N-m} \quad \dots(4.2)$$

In any measuring (electromagnetic) instrument there are three torques acting on the moving mechanism to which a pointer is connected which moves on the dial of the instrument and indicates the reading of the quantity being measured. One of the three torques is the deflecting torque which we have just studied. The other torques are (i) control torque (ii) Damping torque. In case of PMMC instruments spring made of phosphor bronze provides control torque. The spring also serves as leads to the moving coil. When deflecting torque acts on the coil, both the control torque and damping torques come into action. The control torque restrains the rotation of the coil whereas the deflecting torque tries to rotate the coil. At balance, if the coil has moved through an angle θ and if k is the spring constant, we have

$$NBI \cdot 2r = k\theta \quad \dots(4.3)$$

or
$$I = \frac{k\theta}{NBI \cdot 2r} \quad \dots(4.4)$$

$$= k'\theta \quad \dots(4.5)$$

as $NBI \cdot 2r$ are constant of a particular meter. Hence equation (4.5) suggests that the current is proportional to θ . Thus the scale is uniformly divided i.e. it is a linear scale i.e. if for I amp the deflection is through an angle θ , for $2I$ amps the deflection would be 2θ .

Now if damping torque were absent, the pointer will keep on oscillating around the mean value and an exact reading cannot be recorded. These oscillations are damped out by the damping torque. The moving coil is wound on an aluminium former which is placed in the magnetic field. As the coil rotates eddy currents are induced in the aluminium former and these eddy currents would try to oppose the cause i.e. the deflecting force and finally when the pointer comes to its actual value being measured, damping is provided by eddy currents and the coil (the pointer) remains stationary at its actual value.

Following are the advantages of PMMC instruments :

- (a) Low power consumption
- (b) High Torque/weight-ratio
- (c) Uniformity of the scale and the possibility of a very long scale
- (d) Perfect damping provided by eddy currents induced in the metal former of the moving coil. The metal used is aluminium as it is light in weight
- (e) The possibility of a single instrument being used with shunt and resistance to cover a large range of both currents and voltages
- (f) Freedom from errors due to stray magnetic fields.

4.2.2 Dynamometer Type Moving Coil Instruments

In this instrument the permanent magnet is replaced by one or two fixed coils which carry current to be measured or a current proportional to the voltage to be measured and which are connected either in series or parallel with the moving coil. The coils are usually air cored. The torque of the instrument is dependent upon the magnetic field strengths of the fixed and moving coil i.e. the torque is proportional to square of the current in an ammeter and square of the voltage in a voltmeter. Dynamometer instruments can thus be used in alternating current circuits for which square law is essential. These can be as well used for dc circuits also.

When the meter is used as an ammeter Fig. 4.1 (a) or as a voltmeter Fig. 4.1 (b), the torque of the meter is proportional to the product of the flux of the fixed coil (FC) and the flux of the moving coil. The scale of the instrument is thus a square one as shown in Fig. 4.1(e).

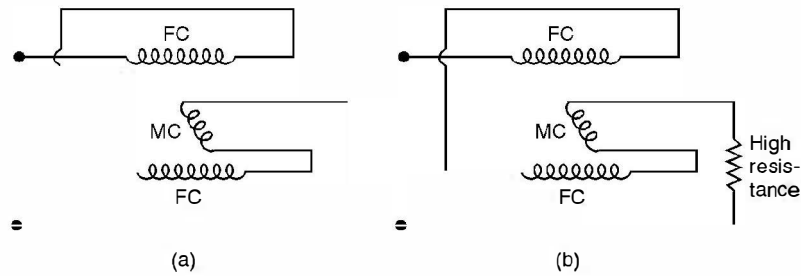

Fig. 4.1. (a) An ammeter (b) A voltmeter.

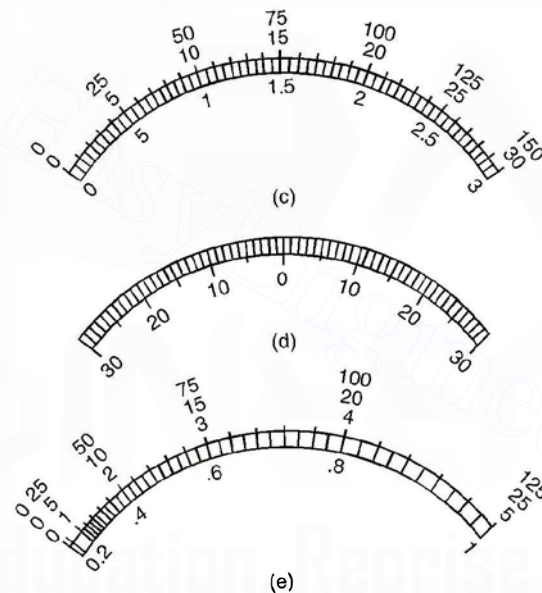

Fig. 4.1. Typical meter scales : (c) linear, (d) zero center, (e) squared.

Since energy must be used to create two magnetic fields, the electrodynamicometer movement is less sensitive as compared to that in PMMC instruments.

The control torque is provided by spring torque. The damping is provided by either eddy currents or air piston attached to the pointer.

These instruments are not in common use as

- (a) They have low torque/weight ratio
- (b) Owing to $T_D \propto I^2$, the scale is non uniform
- (c) These are expensive.

4.3 MOVING IRON TYPE

There are mainly two types of moving iron instruments (a) Attraction type Fig. 4.2 and (b) Repulsion type Fig. 4.3. In these instruments the current to be measured or current proportional to the voltage to be measured is passed through a coil of wire, the no. of turns on which depends upon the current passing through it. A certain number of ampere turns is required to operate the instrument.

When current flows through the coil, a small piece of iron is drawn into the core of the coil in case of attraction type of instruments. In the repulsion type, there are two rods or pieces of iron inside the coil one are fixed and are movable. These are similarly magnetised when current flows through the coil and repulsion of the moving iron from the fixed one takes place. The force of repulsion is roughly proportional to square of the rms value of the current as both magnets are magnetised by the same current.

Whatever be the direction of current through the coil, these are so designed that attraction takes place in case of attraction type of instruments, similarly repulsion takes place in the repulsion type of instruments. These are therefore known as unpolarised instruments in contrast to moving coil permanent magnet type of instruments which are polarised. If the direction of current through the PMMC instrument is changed, the deflection goes in the opposite direction.

Earlier the control torque was provided by attaching a weight to the moving iron and hence due to gravity the control torque is obtained. But now almost universally spring control is used. The damping torque in the moving iron instrument is provided by air friction. Two different types of damping chambers have been shown in Fig. 4.2 and 4.3. The control torque is proportional to the angle θ through which the pointer moves and the deflecting torque is proportional to square of the current being measured i.e.

and

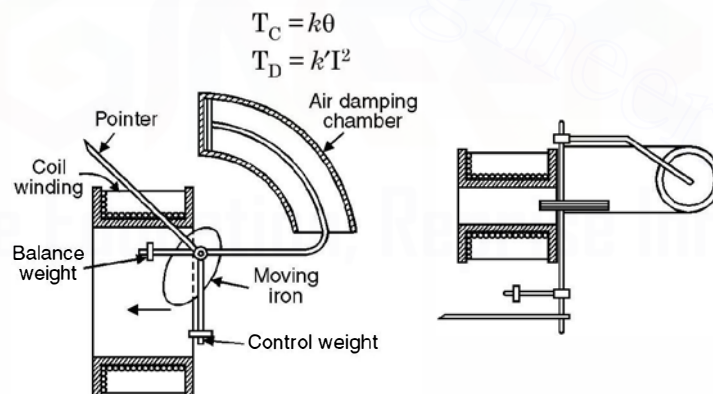

Fig. 4.2. Attraction type of moving-iron instrument.

Hence at balance

$$T_D = T_C$$

$$k'I^2 = k\theta$$

or

$$\theta \propto I^2$$

and, therefore, the scale in case of MI instruments is non uniform. In fact if two meters one MI and another PMMC is placed before us and we are asked to identify looking at the scale. The one

with uniform (linear) scale is PMMC and one with non-uniform (non linear) scale is MI instrument. The scale is normally cramped at the lower end and sparse at the upper end, Fig. 4.1 (c-e).

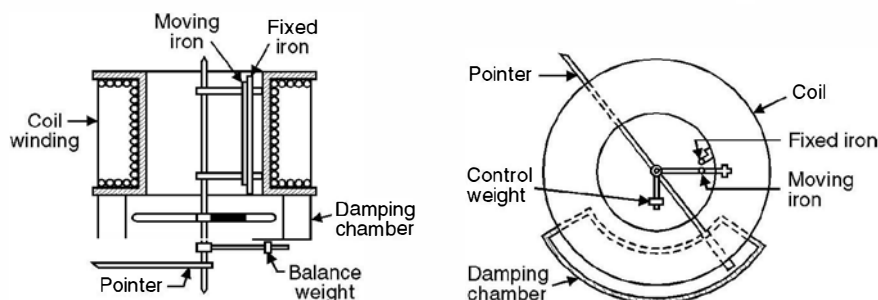

Fig. 4.3. Repulsion type of moving-iron instrument.

Hot wire instruments are normally not used and hence are not discussed.

Electrostatic instruments are used for measurements of high voltage and hence are not in the scope of the book.

4.4 INDUCTION INSTRUMENTS

As the name suggests these instruments can be used in alternating current circuits only. Their main advantage is that a full scale deflection of around 300° can be obtained giving a long and open scale.

These instruments are of two types (i) Induction disc and (ii) Induction cylinder type.

4.4.1 Induction Disc Type or Shaded Pole Type

Consider Fig. 4.4. As shown a thin aluminium disc is mounted on a spindle which is supported by jewelled bearings. The spindle carries a pointer and a control spring is attached to it. The edge of the disc moves in the air gap of a laminated electromagnet which is energized by the current to be measured or by a current proportional to the voltage to be measured. A damping magnet is placed at the opposite side of the disc from the electromagnet so that the damping torque is provided by the damping magnet and deflecting torque is provided by the electromagnet. The poles of the electromagnet are split into two halves with a thin copper band round one-half

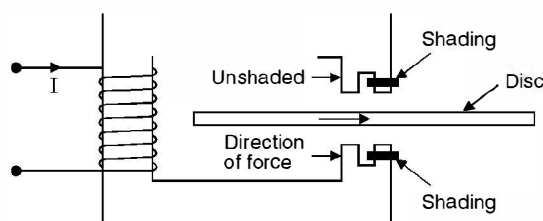

Fig. 4.4. Shaded pole structure.

of each pole (on the same side) as shown. The unshaded and shaded poles produce fluxes where the unshaded pole flux leads the shaded pole flux by an angle α . This is done so that we have two fluxes displaced in time and space acting on the moving system, here the aluminium disc. These

are displaced in time because of the copper band and are displaced in space as these are from two different parts of the electromagnet. In the induction cylinder type of instruments the time displacement is obtained by inserting resistance in one circuit and inductance/capacitance in another circuit and space displacement is obtained by having windings on different pair of poles. In order to obtain uniform torque in the disc it is usually not circular but is spiral shaped. This is due to non-uniform torque provided by the spring torque which increases as the disc moves due to tightening action of the spring. The scale is usually cramped at the lower end since the deflecting torque is proportional to the square of the current or voltage to be measured and spring control is used.

Let the two fluxes be

$$\phi_1 = \phi_m \sin \omega t$$

and

$$\phi_2 = \phi_m' \sin (\omega t + \alpha)$$

Flux ϕ_1 is due to shaded pole whereas ϕ_2 due to unshaded pole. The two fluxes ϕ_1 and ϕ_2 will induce voltages e_1 and e_2 respectively in the disc due to induction. These voltages will circulate eddy current in the disc. Assuming the disc to be non-inductive, these currents will be in phase with their respective voltages. The phasor diagram in Fig. 4.5 shows the phase relation between various quantities.

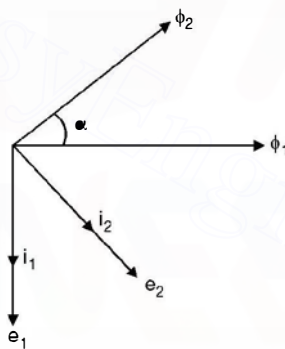

Fig. 4.5. Phasor diagram for induction instrument.

$$e_1 \propto \frac{d\phi_1}{dt}$$

$$\propto \phi_m \omega \cos \omega t$$

and

$$e_2 \propto \phi_m' \omega \cos (\omega t + \alpha)$$

The eddy current $i_1 \propto e_1$.

Assuming same resistance to flow of eddy currents

$$i_2 \propto e_2$$

and

$$i_1 \propto \phi_m \omega \cos \omega t$$

$$i_2 \propto \phi_m' \omega \cos (\omega t + \alpha)$$

The flux ϕ_1 , will interact with eddy current i_2 and ϕ_2 will interact with i_1 and since ϕ_2 is leading ϕ_1 the torque due to ϕ_2 and i_1 will be reckoned as positive whereas that due to ϕ_1 and i_2 as negative. The resultant torque is

$$T_D \propto \phi_2 i_1 - \phi_1 i_2$$

$$\begin{aligned} \therefore & \propto \phi_m' \sin(\omega t + \alpha) \phi_m \omega \cos \omega t - \phi_m \sin \omega t \phi_m' \omega \cos(\omega t + \alpha) \\ & \propto \phi_m \phi_m' \sin(\omega t + \alpha) \cos \omega t - \phi_m \phi_m' \sin \omega t \cos(\omega t + \alpha) \\ & \propto \phi_m \phi_m' \sin \alpha \end{aligned}$$

Thus the torque is maximum when the two fluxes are displaced by 90° and since ϕ_2 leads ϕ_1 the rotation of the disc under the poles will be from unshaded pole to the shaded pole.

$$\begin{aligned} \text{Now At balance} \quad & T_B = T_C \\ \text{and since} \quad & T_C = k\theta \\ \text{Hence} \quad & k'I^2 = k\theta \\ \text{or} \quad & \theta \propto I^2 \end{aligned}$$

The damping torque is provided by a permanent magnet of high retentivity steel. The motion of the disc can be controlled by adjusting the position of this magnet.

4.4.2 Induction Cylinder Type Instrument

For this refer Fig. 4.6.

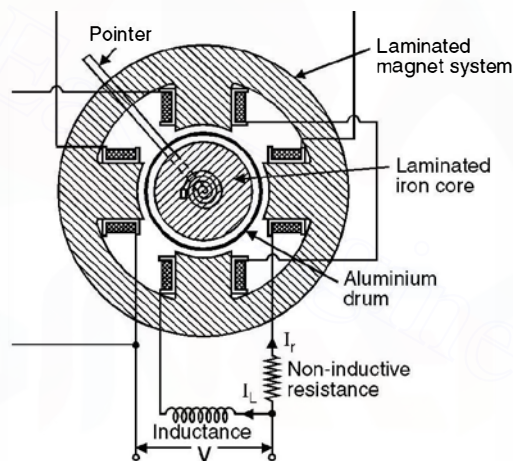

Fig. 4.6. Cylinder type induction instrument.

As mentioned earlier phase displacement between the fluxes is obtained by placing the windings on two different pairs of poles (space displacement) and by placing a high non-inductive resistance in series with one pair of winding and inductance in the other. The flux due to the winding having non-inductive resistance will lead the flux due to the other winding. The principle of operation of the instrument is exactly identical to the induction disc type of instrument.

4.4.3 The Shunt

Meters are available to read current in the ranges from a few microamperes to several hundred amperes full scale. However, the coil structure of the galvanometer movement is not capable of handling current greater than a few mA. Therefore when current to be measured exceeds this limiting value of coil current, the excess current must be diverted or by passed around the meter movement by means of a shunt. A shunt is a small resistance much smaller

than the meter resistance, and is connected across the meter terminals as shown in Fig. 4.7. Let R_m be the meter resistance and R_{sh} the shunt resistance and if

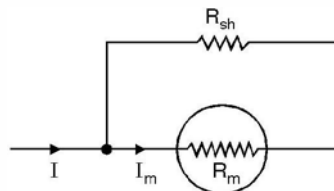

Fig. 4.7. Shunt.

I is the current to be measured the current through the meter I_m is given as

$$I_m = I \cdot \frac{R_{sh}}{R_{sh} + R_m}$$

This current I_m should not exceed the full scale deflection of the meter. The current through the shunt is much larger than I_m .

4.4.4 High Series Resistance (Voltage Indicating Instrument)

Galvanometer instrument is a current indicating device as the coil current produces the coil flux that in turn develops torque for a scale deflection. The coil has a finite value of resistance and since the current through this is also a few miliampères, the net drop across the instrument is in mV and therefore if a voltage in hundred of volts is to be measured a high resistance in series with the galvanometer should be connected as shown in Fig. 4.8.

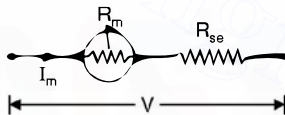

Fig. 4.8. High resistance in series.

When the meter is used to measure a voltage V greater than $I_m R_m$, the difference must be the voltage drop across the series resistance R_{se} . The equation for the voltmeter circuit is

$$V = I_m (R_m + R_{se})$$

Hence to measure V , we require a resistance R_{se} in series

$$R_{se} = \frac{V}{I_m} - R_m$$

However, it is to be calibrated for a voltage V rather than $I_m R_m$.

Example 4.1. The moving coil of a galvanometer has 60 turns, a width of 2 cm and a depth of 3 cm. It hangs in a uniform radial field of 50 mwb/m². Determine the torque on the coil when it is carrying a current of 1 mA.

Solution. It is to be noted that the instruments we have studied so far are galvanometers. When we connect a shunt (low resistance) across the galvanometer it works as an ammeter, of course with suitable calibration and it works as a voltmeter when a high resistance in series with the operating coil is connected.

Now $T_D = NBII \cdot 2r$

Here $N = 60, B = 50 \text{ mWb/m}^2, I = 1 \text{ mA}$

$$l = 3 \times 10^{-2} \text{ m} \quad \text{and} \quad 2r = 2 \times 10^{-3} \text{ m}$$

Substituting the values we have

$$\begin{aligned} T_D &= 60 \times 50 \times 10^{-3} \times 1 \times 10^{-3} \times 3 \times 10^{-2} \times 2 \times 10^{-3} \text{ Nm} \\ &= 1.8 \times 10^{-6} \text{ Nm} \quad \text{Ans.} \end{aligned}$$

Example 4.2. The following data refer to a moving coil voltmeter : resistance $10 \text{ K}\Omega$, dimension of coil $3 \text{ cm} \times 3 \text{ cm}$ $N = 100$, flux density in gap 80 mWb/m^2 , spring control constant $K = 30 \text{ dyne-cm/degree}$. Find the deflection produced by 200 V .

Solution. Here a high resistance of $10 \text{ k}\Omega$ is connected in series with the galvanometer to work as a voltmeter. For measurement of 200 V , the current through the coil is $\frac{200}{10,000} = 20 \text{ mA}$

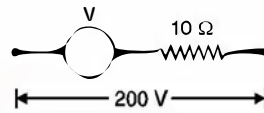

Fig. E4.2

Hence the deflecting torque is

$$\begin{aligned} T_D &= NBll \cdot 2r \\ &= 100 \times 80 \times 10^{-3} \times 20 \times 10^{-3} \times 3 \times 3 \times 10^{-4} \end{aligned}$$

At balance

$$T_D = T_C$$

$$\text{or} \quad 30 \times 10^{-5} \times 10^{-2} \theta = 100 \times 80 \times 180 \times 10^{-10} = 8 \times 18 \times 10^{-6}$$

$$\text{or} \quad \theta = \frac{144 \times 10^{-6}}{30 \times 10^{-7}} = \frac{144 \times 10}{30} = 48^\circ \text{ Ans.}$$

Example 4.3. Two ammeters are joined in series in a circuit carrying 10 A . Ammeter A has a resistance of 1000Ω and is shunted by 0.02Ω . The corresponding values for ammeter B are 1500Ω and 0.01Ω . What will the instruments read if the shunts are interchanged ?

Solution.

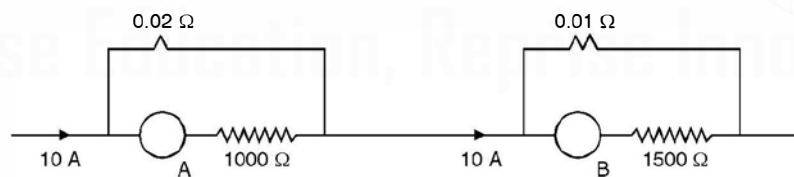

Fig. E4.3

Two meters have been shown. The current in the circuit is 10 A . Both the meters under this situation show 10 A . Now the current through meter A is i.e. through 1000Ω resistance is

$$10 \times \frac{0.02}{1000} = 0.2 \times 10^{-3} \text{ A} \quad \dots(1)$$

and that through meter B i.e. through 1500Ω resistance

$$10 \times \frac{0.01}{1500} \text{ A} \quad \dots(2)$$

Now when these currents flow through the respective meters they indicate a current of 10 A. Please note that it is the current through the meter that decides the reading on that meter and not the current through its shunt.

Now if the shunts are interchanged i.e. the situation is as shown below.

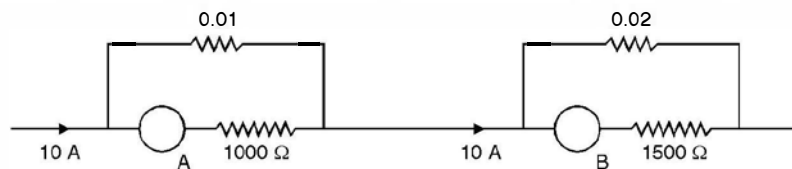

Fig. E 4.3.1

The current through meter A

$$10 \times \frac{0.01}{1000} \quad \dots(3)$$

and that through B

$$10 \times \frac{0.02}{1500} \quad \dots(4)$$

Comparing (1) and (3) and (2) and (4) we find that current in new situation (3) is half of that in (1) hence the meter will read half of its normal value of 10 A i.e. it will read 5 A and comparing (2) and (4), the meter B will read twice its previous value i.e. it will read 20A.

It is to be noted that since the instrument is PMMC, direct relations are possible.

Example 4.4. A moving coil instrument has a resistance of 10Ω and gives full scale deflection when carrying 50 mA . Show how it can be adopted to measure voltages upto 750 V and current upto 100 A .

Solution. The meter has 10Ω internal resistance and gives full scale deflection when current through it is 50 mA .

For 750 V , A high resistance in series should be connected so that the current through the meter is 50 mA when 750 volt is applied across its terminals.

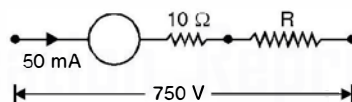

Fig. E 4.4

Hence
$$50 \times 10^{-3} = \frac{750}{R + 10}$$

or

$$R + 10 = 15000 \Omega \quad \text{or} \quad R = 14990 \Omega$$

Hence a resistance of 14990Ω should be connected to read 750 V on the meter.

To read 100 A

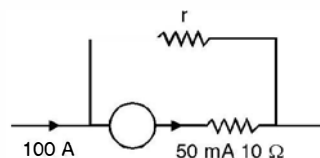

Fig. E 4.4.1

$$50 \times 10^{-3} = 100 \frac{r}{r + 10}$$

since $r \ll 10$

$$\text{Hence } 50 \times 10^{-3} = 100 \frac{r}{10}$$

$$\text{or } r = 50 \times 10^{-4} \Omega \quad \text{Ans.}$$

Example 4.5. In a torsion head type electro-dynamometer a current of 25 A requires a deflection of 90° in the head to give balance (a) Determine the range in Amperes of the instrument (maximum angle 360°) (b) For what current the deflection will be 180° (c) What will be the deflection for a current of 20 A ?

Solution. For this type of meter

$$\theta \propto I^2$$

$$(a) \quad \begin{aligned} 90 &\propto 25^2 \\ 360 &\propto I^2 \end{aligned}$$

$$\text{or } \left(\frac{I}{25}\right)^2 = \frac{360}{90} \quad \text{or } \frac{I}{25} = 2$$

or $I = 50 \text{ A}$ in the full deflection range

$$(b) \quad \begin{aligned} 180 &\propto I^2 \\ 90 &\propto 25^2 \end{aligned}$$

$$\text{or } 2 = \left(\frac{I}{25}\right)^2 \quad \text{or } I = 25\sqrt{2} = 35.4 \text{ A} \quad \text{Ans.}$$

$$(c) \quad \begin{aligned} 90 &\propto 25^2 \\ \theta &\propto 20^2 \end{aligned}$$

$$\text{or } \frac{90}{\theta} = \left(\frac{25}{20}\right)^2 = \frac{625}{400}$$

$$\text{or } \theta = 90 \times \frac{400}{625} = 57.6^\circ. \quad \text{Ans.}$$

4.5 WATTMETER

There are basically three types of wattmeters

- (a) Dynamometer
- (b) Induction
- (c) Electrostatic

Of these three, the first two are most commonly used and will be discussed here.

(a) **Dynamometer Type.** These instruments are similar in design and principle to the dynamometer ammeter already discussed. The fixed coils carry the currents as shown in Fig. 4.9 and are designed to handle the full load current usually 2.5, 5 or 10 A. The potential coil, the moving

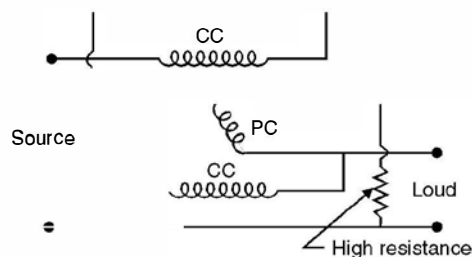

Fig. 4.9. Dynamometer wattmeter.

coil is in series with a high resistance usually designed for two voltage ranges 220/480 volt. Since one flux is proportional to load current and the other is proportional to load voltage, the torque on the pointer or the moving coil is proportional to the power. As a result, the power scale is not square but linear. The moving coil is carried on a pivoted spindle and the movement is spring controlled. The moving system carries a pointer and a damping vane, the latter moving in a sector-shaped box. The current coils are usually stranded or laminated especially when heavy currents are to be carried. For very heavy currents, a low range wattmeter is usually employed in conjunction with a current transformer. Similarly, if the circuit voltage is higher than the rated voltage of the wattmeter, potential transformer can be used in between the circuit and the wattmeter.

Fig. 4.10 shows the connection of current and potential transformers in conjunction with the wattmeter. Here CT is current transformer, PT the potential transformer, CC the current coil of the wattmeter and PC the pressure coil of the wattmeter.

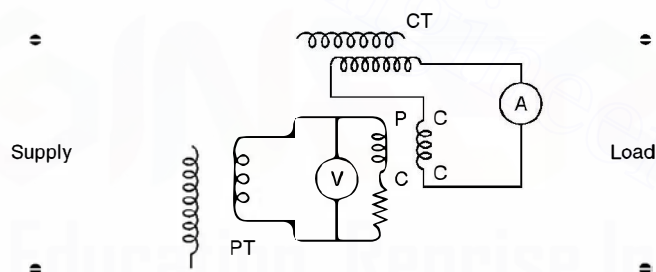

Fig. 4.10. Connection of current and potential transformers with wattmeter.

(b) **Induction Wattmeter.** The basic principle of operation of induction wattmeters is similar to the induction ammeters and voltmeters and can be used only on ac circuits.

Induction wattmeters have two laminated electromagnets, one is excited by the load current or a fraction of the load current and the other is excited by the current proportional to the load voltage. A thin aluminium disc is mounted so that it cuts the fluxes from both the electromagnets and the deflecting torque is produced by the interactions between these fluxes and the eddy currents which they induce in the disc. One or more copper bands or rings are fitted on one limb of the shunt magnet *i.e.* the magnet which is energized by the current proportional to load voltage (pressure coil), so that it causes the resultant flux in the magnet to lag in phase by exactly 90° behind the applied voltage. Fig. 4.11 shows the constructional details of the two types of induction wattmeters whereas Fig. 4.12 shows the phasor diagram for the wattmeter.

Fig. 4.11 shows two common forms of induction wattmeters. The upper one is a shunt magnet carrying pressure coil and the copper rings, the lower one is a series magnet carrying current coil of the wattmeter and the disc is suitably placed in between the two magnets.

In Fig. 4.11 (a) the two pressure coils connected in series are wound so that they both send flux through the middle limb. The series magnet carries two coils in series and are wound on the core such that they both magnetise the core in the same direction. The positions of the copper shading bands can be adjusted so as to obtain correct phase displacement between the shunt and series magnet fluxes.

However, in Fig. 4.11 (b) there is only one pressure coil and one current coil. A copper shading band, whose position is adjustable, surrounds the two projecting pole pieces of the shunt magnet for the purpose of correcting phase of the flux of this magnet. Both use spring to provide control torque and hence the advantage of a long and uniform scale upto 300° .

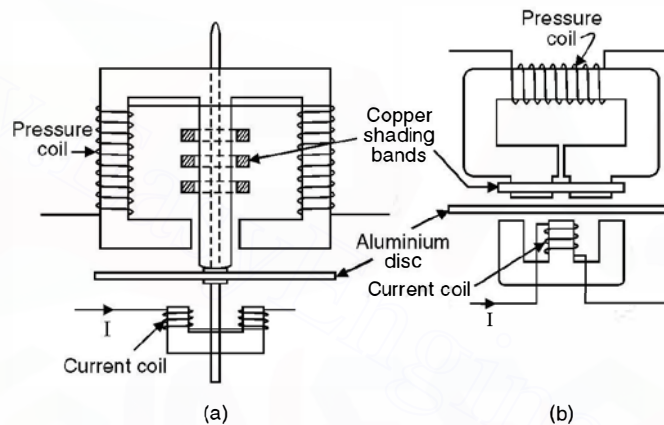

Fig. 4.11. Induction Wattmeters.

In case of dynamometer type of wattmeter a high resistance is connected in series with the pressure load so as to keep current in phase with the voltage. However, in induction type of wattmeters the pressure coil circuit is made as inductive as possible so that the flux due to pressure coil lags its voltage by almost 90° .

Fig. 4.12 shows the phasor diagram for various quantities of the induction wattmeter.

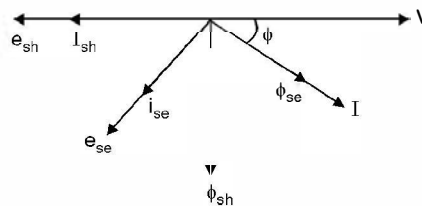

Fig. 4.12. Phasor diagram for induction wattmeter.

Let V be the applied voltage and I the current through the coil. ϕ_{sh} lags behind applied voltage V by 90° and this flux induces voltage e_{sh} in the disc which further lags the flux ϕ_{sh} by 90° as shown in Fig. 4.12. Assuming the aluminium disc to be resistive, current i_{sh} is in phase with

e_{sh} . Now ϕ_{se} is in phase with the current which produces it and e_{se} is the induced voltage in the disc which lags behind ϕ_{se} by 90° and again assuming disc to be resistive i_{se} is in phase with e_{se} .

$$\text{Let } V = V_m \sin \omega t \quad I = I_m \sin (\omega t - \phi)$$

$$\phi_{se} \propto I_m \sin (\omega t - \phi)$$

$$V \propto -\frac{d\phi_{sh}}{dt} \quad \text{or} \quad \phi_{sh} = -\int V_m \sin \omega t dt$$

$$\text{or} \quad \phi_{sh} = -\frac{V_m}{\omega} \cos \omega t$$

$$\text{and} \quad e_{sh} \propto \frac{d\phi_{sh}}{dt} \propto \frac{V_m}{\omega} \omega \sin \omega t$$

$$\propto V_m \sin \omega t$$

$$\text{and} \quad i_{sh} \propto V_m \sin \omega t$$

$$\text{Similarly} \quad e_{se} \propto \frac{d\phi_{se}}{dt} \propto I_m \omega \cos (\omega t - \phi)$$

$$\text{and} \quad i_{se} \propto I_m \omega \cos (\omega t - \phi)$$

The net torque is $\propto \phi_{se} i_{sh} - \phi_{sh} i_{se}$

$$T_D \propto I_m \sin (\omega t - \phi) V_m \sin \omega t + \frac{V_m}{\omega} \cos \omega t I_m \omega \cos (\omega t - \phi)$$

$$\propto V_m I_m [\sin (\omega t - \phi) \sin \omega t + \cos \omega t \cos (\omega t - \phi)]$$

$$\propto V_m I_m \cos (\omega t - \phi - \omega t)$$

$$T_D \propto V_m I_m \cos \phi$$

$$\propto VI \cos \phi$$

$$\propto \text{the power in the circuit.}$$

Since the deflecting torque is proportional to the power in the circuit and the instrument is spring controlled the scale is uniform. Similarly for dynamometer type wattmeter also the scale is uniform

Compared with dynamometer type wattmeters, the induction wattmeter have the advantage of a greater working torque and length of scale. However, they suffer from the inherent disadvantages of less accuracy greater weight of moving system, greater power consumption and also that these can be used only on ac circuits.

4.6 METHOD OF CONNECTION IN THE CIRCUIT

There are two ways in which a wattmeter could be connected in a circuit as shown in Fig. 4.13. There are four terminals in a wattmeter. Across terminals ML is the current coil and across $V_1 V_2$ is the pressure coil. M stands for the mains (supply) side of the current coil and L stands for the load side of the current coil. If connections of any one coil is made opposite to what is shown in Fig. 4.13, the meter would give deflection in the opposite direction and hence the connection of any one of the coils should be reversed to obtain positive deflection. Even though the two connections shown above are normal, neither measures the power in the load accurately.

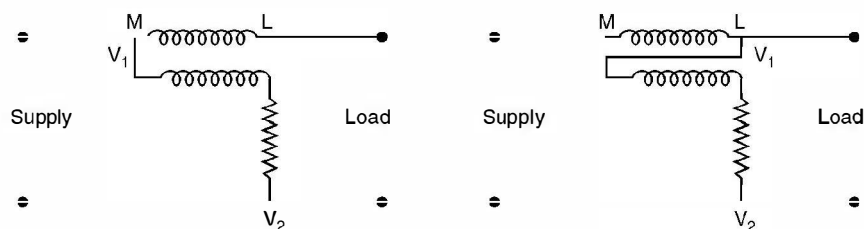

Fig. 4.13. Alternative wattmeter connections.

In Fig. 4.13 (a) where the pressure coil is connected on the supply (Main) side of the current coil, the voltage applied to the pressure coil is higher than that of the load by an amount equal to the drop in the current coil. However, in Fig. 4.13 (b) the current in the current coil is greater than that in the load by an amount equal to the current drawn by the pressure coil.

In the first case, the instrument measures $I^2 R_C$, lost in the current coil and in the second case the watts lost in the pressure coil, as well as the power in the load.

If the load current is small, the volt drop in the current coil is small and hence first connection in Fig. 4.13 is suitable and would introduce small error. However, if the load current is large as compared to the current drawn by the pressure coil, the watts lost in the pressure coil will be small as compared to the watts consumed by the load and the second method of connection is preferred.

4.7 ENERGY METERS

The measurement of energy is the same process as measurement of power except that the instrument not merely indicates the power or rate of supply of energy but must take into account also the length of time for which the rate of energy is continued. There are basically three types of energy meters.

- (a) Electrolytic meters
- (b) Motor meters
- (c) Clock meters.

Out of the above, motor meters are very widely used and among motor meters also induction type watt-hour meters are more commonly used and will be dealt with here.

4.7.1 Single Phase Induction Type Energy Meter

The construction of this meter is more or less similar to induction type wattmeter. The main alterations are the provision of only one pressure coil upon the central limb of the shunt magnet and only one copper shading band upon this limb. In addition there are two copper bands placed obliquely on the other two limbs of this magnet, their objective is to provide compensation against friction error in the meter (see Fig. 4.14).

In this meter the moving system is allowed to revolve continuously instead of being allowed merely to rotate through a fraction of one revolution as in an indicating instrument. The speed of revolution is proportional to the power in the circuit. It follows, therefore, that the no. of revolutions made by the revolving system in any given time is proportional to the energy supplied. The number of revolutions made by the meter is recorded by a counting mechanism consisting of a train of wheels to which the spindle of the rotating system is geared.

The control of speed is brought about by a permanent magnet called the brake magnet. The magnet is placed opposite to the electromagnet used for providing deflecting torque and it induces currents in the disc which produces retarding torque proportional to their magnitude which latter is proportional to the speed of the rotating system. This system attains a steady speed when the retarding torque exactly balances the driving torque produced by the power in the circuit. The braking torque produced by the brake magnet depends upon the strength of the magnet. If ϕ is the flux of the brake magnet, i the current induced by the rotation of the moving system in the field of the brake magnet and T_B is the braking torque, then

$$T_B \propto \phi i$$

If n is the speed of the rotating system (disc) and e the voltage induced in the disc of the meter.

$$e \propto n\phi$$

Let r be the resistance to the path of eddy current i in the disc, hence $i = \frac{e}{r}$

and

$$T_B \propto \phi \frac{e}{r}$$

$$\propto \frac{\phi^2 n}{r}$$

This braking torque equals the constant driving torque T_D when a steady speed of the disc is attained. Thus if N be the steady speed of the meter

$$T'_B \propto \frac{\phi^2 N}{r}$$

and at balance

$$T'_B = T_D \propto \frac{\phi^2 N}{r} \quad \text{or} \quad N \propto \frac{r}{\phi^2} T_D$$

Hence the steady speed attained by the meter for a constant driving torque T_D is directly proportional to the resistance of the path of the induced eddy currents and inversely proportional to the square of the flux of the brake magnet. Therefore, it can be seen that it is very important for brake magnet to have constant magnetic strength throughout the use of the energy meter. It is to be noted that the spring control and pointer of the wattmeter have been replaced in the energy meter by a brake magnet which provides braking torque as explained above.

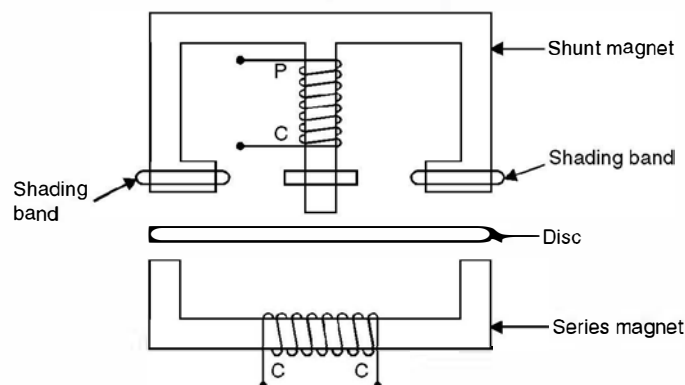

Fig. 4.14. Single phase induction type energy meter.

Using the theory of induction wattmeter.

Operating or driving torque $\propto VI \cos \phi$

where V is the supply voltage across the shunt coil and I the load current through the series coil of the meter and ϕ the p.f. angle between V and I .

Now the braking torque has been shown to be proportional to the speed N of the disc *i.e.*

$$T_B \propto N$$

Since for a steady speed N , the driving torque T_D is equal to T_B , we have

$$N \propto VI \cos \phi$$

or power is proportional to speed N

Thus the total no. of revolutions which equals $\int N dt$ is proportional to

$$\int VI \cos \phi dt \text{ i.e. proportional to energy supplied.}$$

The speed of the disc can be adjusted by suitably positioning the brake magnet with respect to the spindle of the disc. If the brake magnet is moved towards the spindle the braking torque decreases and if taken away from the spindle the braking torque increases.

An energy meter is rated in terms of the supply voltage, the full load current and number of revolutions of the disc per kWhr (also known as constant of the energy meter). These are marked on the dial of the energy meter.

4.7.2 Creep

In some meters a slow but continuous rotation of the disc is obtained when the pressure coils are energized and there is no load current passing through the current coil *i.e.* current coil is not energized. This may be due to incorrect friction compensation to vibration, to stray magnetic field or to the fact that the supply voltage is in excess of the normal voltage.

To prevent such creeping of the meter two holes or slots are cut in the disc on opposite sides of the spindle. The disc tends to remain stationary when one of the holes comes under one of the poles of the shunt magnet. In some cases a small piece of iron wire is attached to the edge of the disc. The force of attraction of the brake magnet upon this iron wire is sufficient to prevent the creeping of the disc under no load condition.

4.7.3 Friction Compensation

The two shading bands embrace the flux contained in the two outer limbs of the shunt magnet and thus eddy currents are induced in them which cause a phase displacement between the enclosed flux and the main gap flux. As a result a small driving torque is exerted on the disc, this torque being adjusted by variation of the position of these bands to compensate for friction torque in the instrument.

The friction compensation can be checked whether it is correct or not by connecting light load under which condition it should run at the correct speed.

4.7.4 Meter Phase Angle Error

It is desired that the phase angle between the applied voltage to the pressure coil and the shunt magnet flux should be at 90° which is adjusted with the help of shading band on the shunt magnet. An error due to incorrect adjustment of the position of this shading band will be evident when the meter is tested on a load whose p.f. is less than unity. An error on the "fast" side under these conditions can be eliminated by bringing the shading band further drawn the limb of the shunt magnet *i.e.* nearer to the disc.

Example 4.6. For 20 A, 230 V meter the constant is 480 revolutions/kWhr. If upon test for a load of 4.6 kW the disc makes 40 revolutions in 66 sec. Calculate the error.

Solution. In 66 sec. the energy consumed by the load is $4.6 \times \frac{66}{3600}$ kWhr = 0.0843 kWhr

The energy recorded by the meter $\frac{40}{480} = 0.0833$ kWhr

Hence the meter is moving slow and it is slow by

$$\begin{aligned} & \frac{0.0843 - 0.0833}{0.0843} \times 100 \\ &= \frac{0.001}{0.0843} \times 100 \approx 1.2 \text{ percent slow.} \end{aligned}$$

4.8 POLYPHASE INDUCTION WATT HOUR METERS

As in the case of power measurement with a two-element wattmeter, the energy supplied to a three phase circuit can be measured by a two element of the induction type, each element being similar to the construction to the single element meter.

There are two discs mounted on the same spindle and two separate brake magnets. The spindle drives a single counting train. In addition to the phase adjustment and friction error compensation in each element, one of the elements has an adjustable magnetic shunt across its shunt magnet, in order that the driving torque for the same watts may be the same in the two instruments. In carrying out this adjustment, the two current coils of the meter are connected in series and the two pressure coils in parallel, the polarities being such that the two driving torques are in opposition. Adjustment of the magnetic shunt is carried out until the meter ceases to rotate with full rated watts supplied to both elements.

The adjustments for phase displacement, friction compensation and for the correct position of the brake magnet are made upon the two elements separately, a single phase circuit being used. The adjustment of the brake magnet positions must be carried out on the two elements alternately, since both magnets are operative in producing the braking torque. Both the shunt elements should be energized meanwhile, to allow for interaction.

The connections to these polyphase meters are the same as those employed in the two wattmeter method of measuring three phase power.

Example 4.7. A dynamometer wattmeter with its voltage coil connected across the load side of the instrument reads 250 W. If the load voltage be 200 V. What power is being taken by the load ? The voltage coil has a resistance of 2000 ohm.

Solution. The connections are as shown

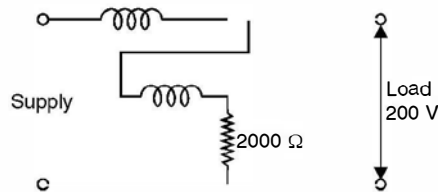

Fig. E4.7

Power taken by the load = Power recorded by the wattmeter – power consumed in the pressure coil.

The current through the pressure coil is

$$\frac{200}{2000} = 0.1 \text{ A}$$

and since the pressure coil is highly non-inductive, power absorbed by the pressure coil is $VI = 200 \times 0.1 = 20$ watts. Hence power taken by the load is $250 - 20 = 230$ watts.

Example 4.8. A 50 A, 230 V meter on full load test makes 61 revolution in 37 sec. If the normal disc speed is 520 revolutions per kWhr. What is the percentage error ?

Solution. The full load is $230 \times 50 = 11.500$ kW

In 37 secs the energy supplied = $11.5 \times \frac{37}{3600} = 0.11819$ kWhr

The energy recorded by the meter = $\frac{61}{520} = 0.1173$

This means the disc or the meter is slow

The percentage error = $\frac{0.11819 - 0.1173}{0.11819} \times 100$
 = 0.75% slow **Ans.**

4.9 PHANTOM OR FICTITIOUS LOAD

When the capacity of a meter under test is high, a test with the ordinary or actual loading would involve a considerable waste of power. To avoid this, phantom or fictitious loading arrangement is employed. In this, voltage across the pressure coil correspond to the rated voltage whereas the current coil is supplied from a separate low voltage source Fig. 4.15. This means that the total power supplied for the test is that due to the small pressure coil current at normal voltage plus that due to the load current at a low voltage and thus the total power supplied is only a comparatively small amount.

If a high capacity meter is to be listed whilst in service, the pressure coil is supplied from the line in the normal way but the current coil is removed from the consumer's load circuit and replaced by a short circuiting connection. The current coil is then supplied from a low voltage source for purposes of testing.

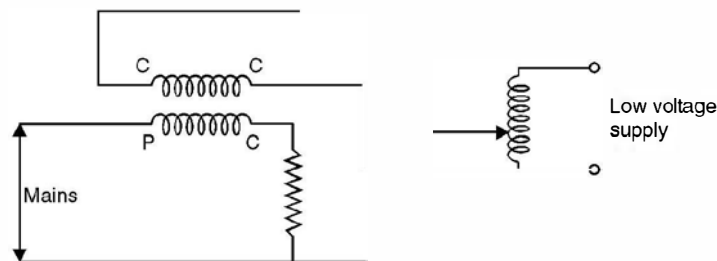

Fig. 4.15. Phantom loading of energy meter.

PROBLEMS

- 4.1. Describe the construction and principle of operation of a moving coil galvanometer.
- 4.2. Explain clearly how a galvanometer can be used as an ammeter or a voltmeter.
- 4.3. Explain the basic requirements of an instrument for measurement.
- 4.4. Explain clearly why a moving coil instrument can be used on dc only and not on a.c. circuits.
- 4.5. Explain why the resistance of an ammeter should be as low as possible whereas that of voltmeter it should be as high as possible.
- 4.6. Explain how an ammeter and a voltmeter are connected in an electric circuit. What will happen if their positions are interchanged?
- 4.7. Explain with neat diagrams the construction principle of operation and application of a moving iron ammeter.
- 4.8. Develop expressions for deflecting torque and control torque for a PMMC instrument and show that the scale of the instrument is linear.
- 4.9. Differentiate between a PMMC and dynamometer type moving coil instrument.
- 4.10. What do you mean by polarised and non-polarised instrument? Classify the instrument: PMMC dynamometer moving coil. Attraction type MI, repulsion type MI.
- 4.11. Name which instrument can be used on ac only, on d.c. only, and on ac and dc both. Give reasons.
- 4.12. What are induction type of instruments? Show that the deflecting torque in an induction disc type instrument is maximum when the two fluxes are 90° phase apart.
- 4.13. Describe the construction, principle of operation and application of an induction disc type of an ammeter. Discuss about its scale.
- 4.14. Explain with diagram the construction, principle of operation and application of (a) Induction type (b) dynamometer type wattmeters.
- 4.15. Explain why the potential coil of a dynamometer wattmeter should be highly non-inductive and that of induction wattmeter highly inductive.
- 4.16. What is meant by creeping of an energy meter? How is this taken care of?
- 4.17. What is phantom loading? With a neat diagram explain how it is carried out.
- 4.18. Explain the construction and principle of operation of a 3-phase energy meter.
- 4.19. The resistance of a meter movement that has a full scale deflection of 1 mA is 50Ω . Calculate the value of the shunt required to convert the movement to an ammeter having a full scale deflection of 2 A. [Ans. $25 \text{ m}\Omega$.]

- 4.20. The resistance of a meter movement is $500\ \Omega$ and the resistance of its shunt is $0.005\ \Omega$. When the line current is $1\ \text{A}$, the meter deflects full scale. What is the full scale deflection current of the meter movement ?
[Ans. $10\ \mu\text{A}$.]
- 4.21. A meter movement has a resistance of $25\ \Omega$ and a full scale deflection of $2\ \text{mA}$. Determine the value of the multiplier (series resistance) required to convert the movement to indicate $300\ \text{V}$ full scale.
[Ans. $149975\ \Omega$.]
- 4.22. A meter movement has a resistance of $50\ \Omega$ and a full scale deflection of $1\ \text{mA}$. Determine the values of the series resistances required to give the movement ranges of $1\ \text{V}$, $3\ \text{V}$ and $30\ \text{V}$.
[Ans. $950\ \Omega$, $2950\ \Omega$, $9950\ \Omega$.]
- 4.23. Explain two possible connections of a 1-phase wattmeter in an electronic circuit. Discuss their application.
- 4.24. A moving coil instrument gives a full scale reading of $24\ \text{mA}$ when the p.d. across its terminals is $72\ \text{mV}$. Calculate (a) the shunt resistance for a full scale deflection corresponding to $120\ \text{A}$ (b) the series resistance for full scale reading with $600\ \text{V}$. Find the power consumption in each case.
[Ans. (a) $0.60012\ \text{m}\Omega$, $8.64\ \text{W}$ (b) $24997\ \Omega$, $14.4\ \text{W}$]
- 4.25. The constant for a 3-phase, 2-element integrating wattmeter is $0.12\ \text{rev}$ of disc per kWhr. If the meter is normally used with a potential transformer of ratio $22000/110\ \text{V}$ and a current transformer of ratio $500/5\ \text{A}$, determine the error, expressed as a percentage of the correct reading, from the following test figures for the instrument only : line voltage $110\ \text{V}$, current $5.25\ \text{A}$ p.f. unity, time to complete 40 revolutions $61\ \text{secs}$.
[Ans. -1.68%]

ENGINEERING INNOVATIONS
© Apprise Education, Reprise Innovations ©

CHAPTER

5

Transformer

5.1 INTRODUCTION

A transformer even though is not an energy conversion device, it forms a very important component of the energy conversion system. It is almost an indispensable component in both the electric and electronic systems. A transformer transforms electric energy from a certain voltage and current levels to another voltage and current levels keeping the frequency of the supply the same. It is because of the availability of the transformer that it is possible to generate energy from where it is available in abundance far away from the load centre and the energy so generated at economic voltage levels can be transmitted at economic voltage levels using transformers and the same energy can be utilised at economic and safe voltage levels as required by the devices using the electric energy. The importance of transformer in electric energy system can be gauged by the fact that a generation of 1 MW requires transformers of 3 to 3.5 MVA capacity from power plant to the consumer points.

The transformer is also very widely used in electronic circuits i.e. low power low current electronic and control circuits for performing such functions as matching the impedance of a source and the load for maximum power transfer. A transformer has normally two windings, the primary and the secondary. The primary is one where the source is connected and across the secondary load is connected. If the secondary voltage is higher than the primary voltage it is known as step-up transformer and it is known as step down if the secondary voltage is smaller than the primary voltage. However, if the two voltages are equal, it is known as an isolation transform. The one-to-one transformers are used when it is necessary or desirable to insulate the secondary side of the circuit from the primary circuit ; for though both the circuits will then have the same difference of potential between their terminals, they will not necessarily have the same difference of potential to ground. It is to be noted that either of the two windings can be considered as primary while the other then serves as the secondary. The primary is therefore defined as one which receives energy from the supply and the secondary as the one which delivers energy to the load. In general, however, the windings are designated as low tension (LT) or high tension (HT) windings.

In its simplest form the transformer consists of the insulated windings wound on a ferromagnetic core and so disposed with respect to each other as shown in Fig. 5.1 that a current through one of the windings will set up a magnetic flux linking more or less completely with the turns of the other. According to Faraday's laws of electromagnetic induction an emf is induced in the secondary which is proportional to the number of turns of the secondary and the flux linking the secondary. However, the frequency of the secondary voltage is same as that of the source.

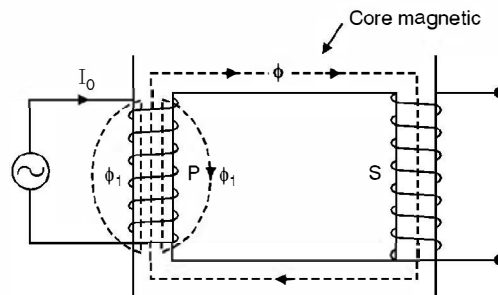

Fig. 5.1. A transformer (Basic).

In order to ensure the most effective magnetic linkage of the two windings, the core which serves to support them mechanically as well as to carry their mutual magnetic flux is usually made of a highly permeable iron or steel alloy designed to have a low reluctance. In some specially designed transformers the core may be of non-magnetic materials. Such transformers are known as air cored transformers. These transformers are normally used in radio devices and in certain types of measuring and testing instruments.

5.2 CONSTRUCTION

The main considerations in the construction of the transformer are simplicity and ease of construction, economy of material, provision of insulation to withstand electrical stresses, mechanical strength to withstand the forces caused by heavy short circuit currents and ventilation to get rid of the heat due to the losses in the coils and the core. Mainly there are two designs to meet these requirements (i) core type and (ii) shell type as shown in Fig. 5.2 (a) and (b) respectively.

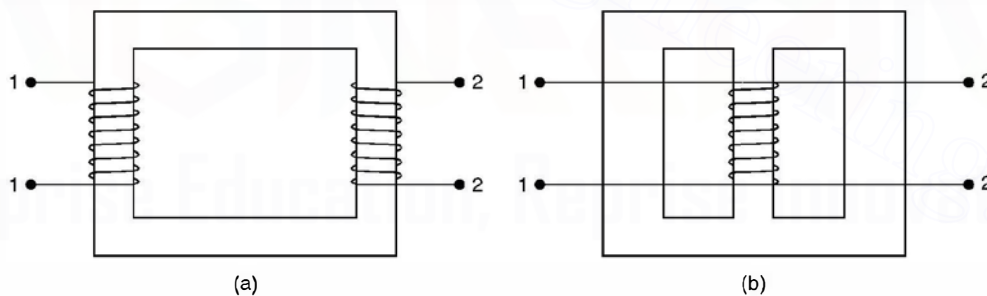

Fig. 5.2. (a) Core type (b) Shell type.

The distinction between the two types can be summed up by the fact that in the core type the windings encircle the core whereas in shell type the core encircles the windings. Out of the two the core type is normally preferred because of additional advantages of permitting visual inspection of the coils in case of fault and of greater ease in making repairs on the site of installation.

It is to be noted that both the windings (primary and secondary or LT and HT) are wound on both the limbs of the core type as well as shell type.

A portion of the LT winding in the form of a coil is placed close to the core from electrical stresses point of view and then over this we have HT coil and so on. Both the windings will be on both the limbs of the core type construction.

5.3 EMF EQUATION OF A TRANSFORMER

Refer to Fig. 5.1. Let N_1 be the no. of turns in the primary and N_2 turns in the secondary and assume that the secondary is open as shown in Fig. 5.1. Hence no current flows through the secondary of the transformer and under this condition the transformer acts as a reactance coil and the current I_0 flowing through the primary will depend upon the supply voltage V_1 and the impedance of the primary winding. Assume that the voltage V_1 varies harmonically with frequency f Hz and the core of the transformer is unsaturated *i.e.* flux ϕ increases linearly with the current. Note that ϕ is a function of mmf which is the product of current and no. of turns of the coil through which current flows and the resistance of the coil is negligible. The current is harmonically varying since the impressed voltage is harmonically varying and the transformer acts as the inductive reactance. As the current increases from its initial value of zero, the flux ϕ increases in direct proportion and since the flux is also varying harmonically, it will induce an emf in the primary winding according to Faraday's law of induction and the polarity of the emf will be as per Lenz's law in opposition of the impressed voltage V_1 . Since by hypothesis the primary has no resistance, the resistance ohmic drop is zero and hence the primary winding is the seat of only two opposing emfs namely the impressed voltage V_1 and the counter emf E_1 induced by the alternating flux and in accordance with Kirchhoff's voltage law, these two emfs must at every instant be equal and opposite.

Since the impressed voltage is varying harmonically the counter emf also must vary harmonically and hence the flux. Suppose flux at any instant is given by

$$\phi = \phi_m \sin \omega t \quad \dots(5.1)$$

where ϕ_m is the maximum value of flux in webers (Wb), it follows that the instantaneous value of the induced emf. in N_1 turns of the primary is

$$\begin{aligned} e_1 &= -N_1 \frac{d\phi}{dt} = -N_1 \omega N_1 \phi_m \cos \omega t \\ &= 2\pi f N_1 \phi_m \sin (\omega t - \pi/2) \end{aligned} \quad \dots(5.2)$$

This means the flux induces a sinusoidal voltage which lags behind the flux itself by 90° in time phase.

The maximum value of the induced voltage from equation 5.2 is

$$E_{1max} = 2\pi f \phi_m N_1 \quad \dots(5.3)$$

and hence its effective or rms value is

$$E_1 = \sqrt{2} \pi f N_1 \phi_m = 4.44 f N_1 \phi_m \quad \dots(5.4)$$

and this also equals the impressed voltage in magnitude. Fig. 5.3 shows the phasor diagram of the various quantities studied so far (ideal transformer or lossless transformer).

Since I_0 lags the supply voltage V_1 by 90° , the power supplied from the source is $V_1 I_0 \cos 90^\circ$ which is zero. This result is a natural consequence of our assumption that the transformer is lossless. Therefore, under these conditions $I_0 = V/X_0$ where X_0 is the reactance of the transformer.

Similarly emf induced in the secondary winding is

$$e_2 = -N_2 \frac{d\phi}{dt} = 2\pi f N_2 \phi_m \sin (\omega t - \pi/2) \quad \dots(5.5)$$

or

$$E_2 = 4.44 f N_2 \phi_m \quad \dots(5.6)$$

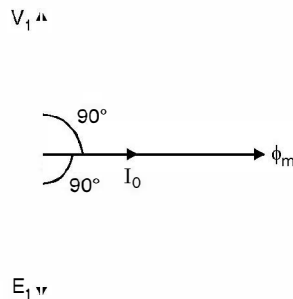

Fig. 5.3. Phasor diagram of ideal transformer, secondary open circuited.

Hence
$$\frac{E_2}{E_1} \approx \frac{V_2}{V_1} = \frac{N_2}{N_1} = n \quad \dots(5.6 A)$$

where n is known as ratio of transformation.

5.4 NO LOAD OPERATION

Refer again to Fig. 5.1. A real life transformer has resistance R_1 of the primary winding and R_2 of the secondary winding and a copper loss of $I_0^2 R_1$ will certainly take place in the primary winding of the transformer (No load condition). Also, since the flux is harmonically varying, it will cause hysteresis and eddy current loss in the ferromagnetic material of the core. Even though eddy current losses in the core can be reduced by laminating the core rather than using solid core and the hysteresis loss can be reduced by using a high permeability core material. However, these losses are always present and hence even though the secondary is open, the primary must supply power to meet the $I_0^2 R_1$, eddy current and hysteresis losses (iron losses). Therefore, this loss must be supplied from the source and hence I_0 should not lag V_1 by 90° but an angle less than 90° . Rather it should lead ϕ by a small angle α known as no load angle or angle of hysteric advance as shown in Fig. 5.4

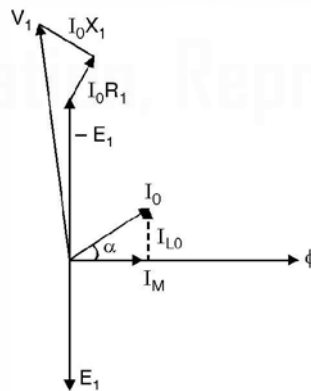

Fig. 5.4. Phasor diagram of transformer under no load condition.

The no load primary current may be decomposed into two components, one in phase with the flux ϕ and hence known as magnetising component of current while the other component I_w as

the working component of the no load current in phase with $-E_1$ and is to meet the losses of the transformer.

Now the flux ϕ produced by the primary does not completely enclose the secondary winding through the core of the transformer. A part of the flux ϕ , completes its path through the air as shown in Fig. 5.1 and hence this component of flux does not contribute to the emf. in the secondary winding and hence this could be considered as a series voltage drop in the primary winding and is usually represented by $I_0 X_1$ where X_1 is known as the primary leakage reactance. The quantity $I_0 X_1$ leading I_0 by 90° , then represents the component of the impressed voltage required to balance it.

Finally, if we include the resistance component R_1 of the primary, it is evident that the impressed voltage V_1 must contain as one component the potential drop $I_0 R_1$ in phase with I_0 as shown in Fig. 5.4 consequently the total supply voltage V_1 must be the phasor sum of (i) the component $-E_1$ equal and opposite to the emf induced by the mutual flux (ii) $I_0 X_1$ the leakage reactance drop equal and opposite to the emf induced by the leakage flux ϕ_1 and (iii) the ohmic drop $I_0 R_1$ in phase with I_0 . The phasor sum of $I_0 R_1$ and $I_0 X_1$ is $I_0 Z_1$ where Z_1 is called the leakage impedance of the primary. It is to be noted that in a real life situation $I_0 Z_1$ forms a very very small fraction of the supply voltage and also $I_0^2 R_1$ also is a small fraction of the core losses or iron losses and hence $I_0 Z_1$ is neglected as compared to V_1 and $I_0^2 R_1$ as compared to core losses and hence an equivalent circuit of the transformer under no load condition is shown in Fig. 5.5.

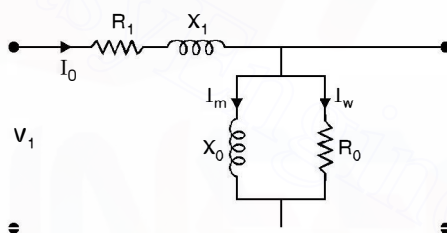

Fig. 5.5. Equivalent circuit of a transformer under no load condition.

Here X_0 represents exciting reactance of the transformer whereas R_0 represents the resistance to account for the core losses such that

$$I_m = \frac{V_1}{X_0} \quad \text{and} \quad I_w = \frac{V_1}{R_0} \quad \dots(5.6 B)$$

$$\text{Core loss} = \frac{V_1^2}{R_0}, \quad I_0 = \sqrt{I_m^2 + I_w^2}$$

and

$$\cos \alpha = \frac{I_m}{I_0} \quad \text{or} \quad \alpha = \tan^{-1} \frac{I_w}{I_m} = \tan^{-1} \frac{X_0}{R_0}.$$

Example 5.1. A 1-phase transformer has 400 primary and 1000 secondary turns. The net cross sectional area of the core is 60 cm^2 . If the primary is connected to a 50 Hz supply at 500 V, determine (a) the peak value of the flux density in the core and (b) the voltage induced in the secondary winding :

Solution. The emf equation of the transformer is

$$E_1 = 4.44 f N_1 B_m A$$

where B_m is the maximum or peak value of the flux density in the core of the transformer

Neglecting the leakage impedance drop

$$E_1 = V = 500 = 4.44 \times 50 \times 400 \times B_m \times 60 \times 10^{-4}$$

Hence $B_m = 0.938 \text{ Wb/m}^2$ **Ans.**

(b) To find out secondary voltage we make use of the relation

$$\frac{E_2}{E_1} = \frac{V_2}{V_1} = \frac{N_2}{N_1}$$

Substituting the values of V_1 , N_2 and N_1 we have

$$V_2 = V_1 \frac{N_2}{N_1} = 500 \times \frac{1000}{400} = 1250 \text{ volt} \quad \text{Ans.}$$

Example 5.2. A single phase 50 Hz core type transformer has core of cross section area 400 sq. cms. The permissible maximum flux density is 1 Wb/m². Calculate the number of turns per limb on the high and low voltage sides for a 3000/220v ratio.

Solution. The area of cross-section of the core is

$$20 \times 20 \times 10^{-4} = 400 \times 10^{-4} \text{ sq m}$$

Neglecting the series voltage drop

$$V_1 \simeq E_1 = 4.44 f N_1 B_m A$$

or $3000 = 4.44 \times 50 \times N_1 \times 1 \times 400 \times 10^{-4}$

or $N_1 = 338$ turns

and $N_2 = 338 \times \frac{220}{3000}$ using the relation

$$\frac{V_1}{V_2} = \frac{N_1}{N_2}$$

Hence $N_2 = 24.78$ i.e. 26 turns

Since there are two limbs the no. of turns per limb will be

$$\frac{338}{2} = 169 \text{ and } \frac{26}{2} = 13 \text{ turns respectively.}$$

5.5 OPERATION OF TRANSFORMER UNDER LOAD CONDITION

Refer to Fig. 5.6, when the secondary of a transformer is open an emf E_2 is induced in the secondary given by equation 5.6 which is a result of mutual flux ϕ_m between the primary and secondary windings.

Now, if the external circuit of the secondary is connected through the impedance represented by $Z = R + jX$ as shown in Fig. 5.6, the induced emf E_2 will set up in the secondary a current

$$I_2 = \frac{E_2}{(R_2 + R) + j(X_2 + X)} \quad \dots(5.7)$$

Where R_2 is the resistance of the secondary winding, X_2 is the equivalent reactance of the secondary winding corresponding to its leakage flux i.e. the part of the flux which links the secondary and not the primary. The current I_2 lags the voltage E_2 by an angle θ_2' given by

$$\theta_2' = \tan^{-1} \frac{X_2 + X}{R_2 + R} \quad \dots(5.8)$$

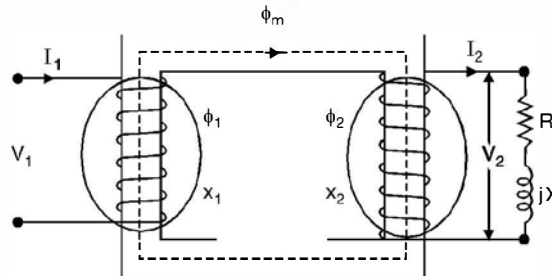

Fig. 5.6. Transformer under load condition.

The current I_2 induces current I_1' in the primary in such a way that the ampere turns $I_2 N_2$ must equal $I_1' N_1$ and the flux produced due to $I_2 N_2$ ampere turns must equal and oppose the flux produced by $I_1' N_1$ ampere turns leaving behind the flux ϕ_m in the core corresponding to the no load flux. Therefore, the current drawn by the secondary winding is reflected in the primary winding such that the net ampere turns remain $I_0 N_1$ i.e. if the current in the secondary increases, there is increase in the primary current also. For all values of secondary currents which provides demagnetising effect as far as flux in the core is concerned, there is a primary current such that

$$I_1' N_1 = I_2 N_2 \quad \dots(5.9)$$

Normally I_0 is a negligible fraction of I_1' and hence

$$I_1' \simeq I_1$$

and hence equation (5.9) becomes

$$I_1 N_1 = I_2 N_2 \quad \text{or} \quad \frac{I_1}{I_2} = \frac{N_2}{N_1} \quad \dots(5.10)$$

i.e. the current in the windings are in the inverse ratio of the turns of the windings whereas the voltages induced are directly proportional to the turns ratio i.e. larger the number of turns of a winding, larger is the induced voltage and smaller the current and vice versa.

Current I_1 is the phasor sum of I_1' and I_0

Current I_2 is also given by the equation

$$I_2 = \frac{V_2}{R + jX} \quad \dots(5.11)$$

where I_2 lags V_2 by an angle $\theta = \tan^{-1} \frac{X}{R}$... (5.12)

Fig. 5.7 shows ampere turn phasor diagram

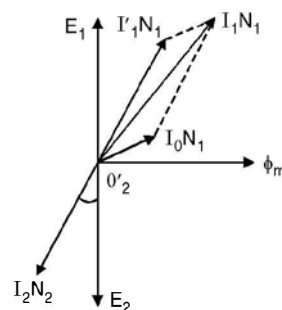

Fig. 5.7. Ampere turns phasor diagram for the transformer.

Fig. 5.8 shows the phasor diagram of the transformer under load condition. It is to be noted that if the ratio of transformation is large, the phasor diagram can't be drawn on the sheet to scale. Assuming the ratio of the transformation to be near unity, Fig. 5.8 gives relative locations of various phasors.

As V_1 is the phasor sum of E_1 and the series impedance drop $I_1(R_1 + jX_1)$, similarly V_2 is obtained after subtracting the drop $I_2(R_2 + jX_2)$ from E_2 .

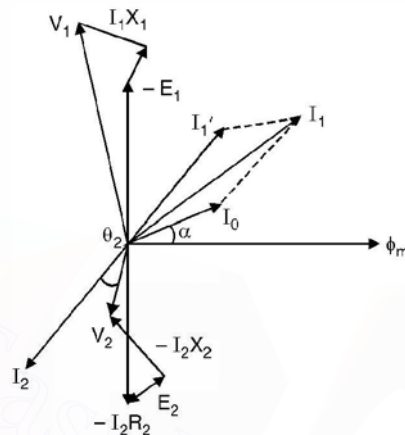

Fig. 5.8. Phasor diagram of transformer under load condition.

From equation (5.6 A) and (5.10) we have

$$\frac{N_2}{N_1} = \frac{I_1}{I_2} = \frac{E_2}{E_1} \quad \dots(5.13)$$

We have already concluded that since the series impedance drop on the primary side is negligible as compared to the supply voltage $V_1 \simeq E_1$. Similarly on the secondary side also $V_2 \simeq E_2$ and hence equation (5.13) can be rewritten as

$$\frac{N_2}{N_1} = \frac{I_1}{I_2} = \frac{V_2}{V_1}$$

or

$$V_1 I_1 = V_2 I_2 \quad \dots(5.14)$$

This means the volt-amperes supplied to the primary are equal to the volt-amperes developed in the secondary. This shows that the transformer transforms voltage and current at certain level to voltage and current at another level related through the transformation ratio n . There is no change in frequency.

The transformer is rated in terms of VA or KVA or MVA depending upon the size as the criterion for design is the heating of transformer which depends upon such rating rather than KW rating.

5.6 EQUIVALENT CIRCUIT

Fig. 5.9 shows equivalent circuit for a transformer for analysis purposes. However, there is a word of caution for this equivalent circuit especially in regard to various quantities indicated therein.

From the equivalent circuit, it appears

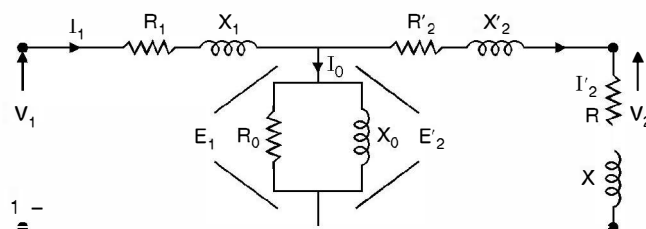

Fig. 5.9. Equivalent circuit of transformer.

$$E_2' = E_1 \quad \text{and} \quad I_1 = I_2' + I_0 \quad \dots(5.15)$$

whereas from equation 5.6 A

$E_2 = nE_1$ where n is the ratio of transformation. Similarly from equation (5.10)

$$\frac{I_1}{I_2} = n \quad \text{or} \quad I_2 = \frac{I_1}{n} \quad \text{or} \quad I_1 = nI_2 \quad \dots(5.16)$$

In equation 5.6 A and equation (5.10) the induced voltage E_2 is the actual voltage induced in the secondary whereas in the equivalent circuit of Fig. 5.9. E_2' is the secondary voltage when referred to the primary winding and is equal to $\frac{E_2}{n}$ whereas the current in actual secondary winding is I_2 but when referred to primary winding it equals nI_2 . So voltage quantities on the secondary side are referred to the primary side by dividing actual secondary voltage by the ratio of transformation (n) whereas the current quantities on the secondary side are referred to primary side by multiplying the actual secondary current by ratio of transformation n .

However, if we want the equivalent circuit referred to secondary side, the ratio of transformation will be used in the reverse fashion *i.e.* $E_1' = nE_1$ and $I_1' = \frac{I_1}{n}$ where n is again as defined in equation (5.6 A).

In Fig. 5.9 R_2' , X_2' , R' and X' are the resistances and reactances of the secondary side when referred to the primary side whereas R_2 , X_2 , R and X are the actual secondary quantities. To find out the referred quantities in terms of the actual quantities we proceed as follows :

The actual drop in the resistance of the secondary is

$$V_r = I_2 R_2 \quad V_r' = \frac{V_r}{n} \quad \text{and} \quad I_2' = nI_2$$

Hence
$$\frac{V_r'}{I_2'} = \frac{V_r}{n} \cdot \frac{1}{nI_2} = \frac{V_r}{I_2} \cdot \frac{1}{n^2} = \frac{R_2}{n^2} = R_2' \quad \dots(5.17)$$

Similarly it can be shown that $X_2' = \frac{X_2}{n^2}$, $R' = \frac{R}{n^2}$ and $X' = \frac{X}{n^2}$.

It is to be noted that electrical connection of primary and secondary windings as shown in Fig. 5.9 is possible only when the electrical quantities are referred to one particular winding otherwise not, as the two windings are coupled only through magnetic circuit.

Let us see the validity of quantities from secondary to primary side. Assume secondary is an HT winding and primary the LT winding *i.e.* it is a step up transformer and hence as defined in equation 5.6 A, $n > 1$ and $E_2 > E_1$. Also $N_2 > N_1$, therefore $R_2 > R_1$ and $X_2 > X_1$. If now E_2 is to be referred to primary side, it must be divided by n and R_2 and X_2 must be divided by n^2 so as to

have these quantities more or less of the same order as the primary quantities and hence after referring the secondary quantities to primary side, electrical connection of the two windings is possible.

In the preceding analysis we have seen that $V_1 \simeq E_1$, the difference is very small due to the drop of potential through the primary leakage impedance. Also the exciting current I_0 is a small fraction of the primary full load current, so that I_2' (or I_2 referred to primary) is practically equal to I_1 . Therefore, no appreciable error will be introduced by transferring the shunt branch in Fig. 5.9 to the one shown in Fig. 5.10 which is the approximate equivalent circuit of the transformer.

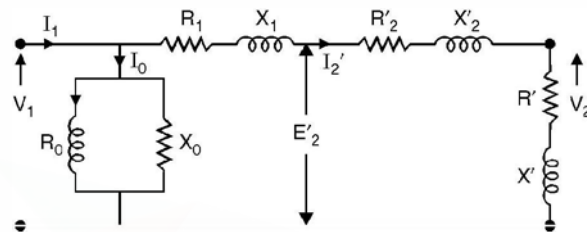

Fig. 5.10. Approximate equivalent circuit of the transformer.

Since I_0 is negligibly small as compared to I_1 or I_2'

$$I_1 \simeq I_2'$$

and the phasor diagram for the approximate equivalent circuit in Fig. 5.10 is shown in Fig. 5.11.

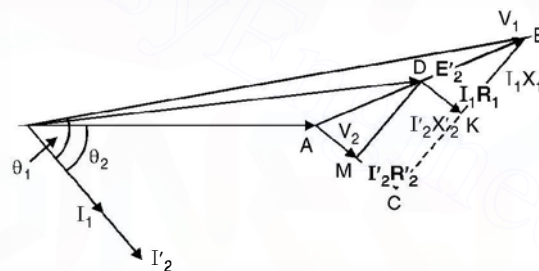

Fig. 5.11. Phasor diagram (simplified) of approximate equivalent circuit.

In this phasor diagram V_2 is taken as the reference phasor I_2' lags V_2 by an angle θ_2 , the p.f. angle of the load. To V_2 is added drop $I_2'R_2'$ parallel to I_2' and $I_2'X_2'$ perpendicular to $I_2'R_2'$. The phasor sum of V_2 , $I_2'R_2'$ and $I_2'X_2'$ gives E_2' as shown in Fig. 5.10. We further add drops I_1R_1 and I_1X_1 to E_2' to get V_1 , the supply voltage. The current I_1 lags V_1 by an angle θ_1 as shown in Fig. 5.11. In triangle ABC in Fig. 5.11 has side MD parallel to CB and DK is parallel to AC, hence

$$\frac{R_1}{R_2'} = \frac{X_1}{X_2'} \quad \dots(5.18)$$

i.e. the ratio of primary resistance to secondary resistance referred to primary equals the ratio of their corresponding reactances. This is very important and proves quite useful when the transformers are connected in parallel and share a load. The secondary current of the two transformers will be in phase with each others.

Example 5.3. A single phase transformer has 180 and 90 turns respectively in its secondary and primary windings. The respective resistances are 0.233 Ω and 0.067 ohm. Calculate the

equivalent resistance of (a) the primary in terms of the secondary winding (b) the secondary in terms of the primary winding and (c) the total resistance of the transformer in terms of the primary.

Solution. Here $\frac{N_2}{N_1} = n = \frac{180}{90} = 2$
 $R_1 = 0.067$ and $R_2 = 0.233$

(a) Resistance of primary in terms of the secondary.

Since resistance of LT winding is to be referred to the HT winding. The ratio of transformation $n = 2$, hence $n^2 R_1 = R_1' = 4 \times 0.067 = 0.268 \Omega$.

(b) Resistance of secondary in terms of primary

$$R_2' = \frac{R_2}{n^2} = \frac{0.233}{4} = 0.058 \Omega$$

(c) Total resistance of the transformer in terms of the primary winding

$$R_1 + R_2' = 0.067 + 0.058 = 0.125 \Omega \quad \text{Ans.}$$

Example 5.4. A 40 KVA transformer with a ratio of 2000/250 V has a primary resistance of 1.15 Ω and a secondary resistance of 0.0155 Ω . Calculate

(a) the total resistance in terms of the secondary winding

(b) total copper loss on full load.

Solution. The ratio of transformation $\frac{250}{2000} = \frac{1}{8} = n$

The total resistance in terms of secondary winding is

$$R_2 + R_1'$$

Now $R_1' = R_1 n^2 = 1.15 \times \frac{1}{8^2} = 0.0179$

Hence total resistance on secondary side is

$$0.0155 + 0.0179 = 0.0334 \Omega.$$

(b) Now total copper loss on full load

$$= I_1^2 R_1 + I_2^2 R_2$$

Where I_1 and I_2 are full load current on the primary and secondary side respectively.

The rating of the transformer is 40 KVA or 40,000 VA and primary voltage is 2000 V.

Hence full load primary current $= \frac{40,000}{2000} = 20 \text{ A}$

Similarly full load secondary current $= \frac{40,000}{250} = 160 \text{ A}$

Hence full load copper loss $= 20^2 \times 1.15 + 160^2 \times 0.0155$
 $= 460 + 396.8 = 856.8$

Alternatively, the same result can be obtained if we refer the total resistance to one side and corresponding to the full load current on that side we can find out the total copper loss.

In part (a) we have found out the total equivalent resistance of the transformer on the secondary side to be $0.0334\ \Omega$ and full load current on secondary side is 160 A. Hence total copper loss.

$$160^2 \times 0.0334 \simeq 855 \text{ watts}$$

It is same as obtained above. The small difference is because of round off error.

From the above analysis it is clear that we can study the performance of a transformer if we know the various parameters of the transformer *viz* R_0 , X_0 , R_1 , R_2 , X_1 and X_2 . To find of R_0 , X_0 we perform on the transformer what is known as No load or open circuit test and to find out the leakage impedances we perform short circuit test. These tests and the procedure to obtain these parameters are discussed in the following articles.

5.7 NO LOAD OR OPEN CIRCUIT TEST

As the name suggests the test is to be performed when the transformer is not loaded *i.e.* the secondary winding is open circuited. The following connections are made as shown in Fig. 5.12.

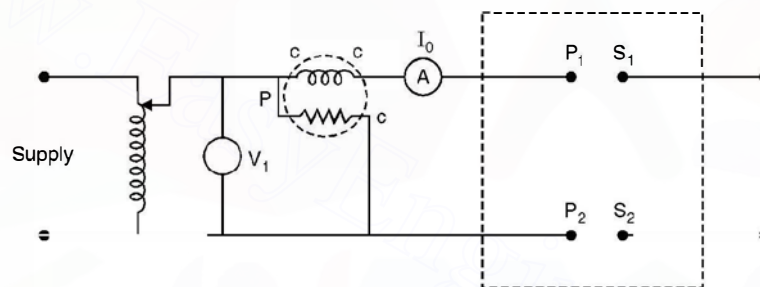

Fig. 5.12. Circuit diagram for O.C. test.

For O.C. test rated voltage should be applied to the transformer and a wattmeter to measure loss (power) and an ammeter to measure no load current should be connected as shown in Fig. 5.12 and the secondary should be left open. Now for a transformer, as mentioned earlier there is no fixed primary or secondary winding. The winding where the supply is connected becomes the primary and the other the secondary. Since the rated voltage is to be applied, it is safer from operation point of view to use LT winding as the primary winding. Also the meters required for conducting the O.C. test will have low ratings and are easily available in testing laboratories. So we use LT winding as the primary winding. Since I_0 is about 5% of full load current, a suitable range ammeter can be used. Under no load condition the pf is low, therefore, a low p.f. wattmeter should be used. Wattmeter also has both potential coil (voltage rating) and current coil (current rating), these must be considered while selecting wattmeter. In order to have good results it is very important to select proper range meters.

Suppose the observation of the meters after rated voltage is applied to the LT winding are as follows.

Voltage V_1 , current I_0 and wattmeter reading is P_i watts. Here suffix *i* is used to indicate iron losses which includes eddy current and hysteresis losses. These losses are a function of voltage for a given frequency and core dimensions and hence are sometimes known as constant losses since the primary under normal conditions is connected across rated supply voltage.

$$\text{Eddy current loss} \propto V^2$$

and

$$\text{Hysteresis loss} \propto V^x$$

Where x varies between 1.6 to 2. Under the no load condition as shown in Fig. 5.12, the wattmeter also measures copper loss corresponding to $I_0^2 R_1$ in addition to constant iron loss, but as I_0 is about 5% of full load current the copper loss under this condition is negligibly small as compared to iron loss and hence it is neglected.

Referring to Fig. 5.10, the approximate equivalent circuit of the transformer, and using equation (5.6 B)

$$P_i = \frac{V_1^2}{R_0} \quad \text{or} \quad R_0 = \frac{V_1^2}{P_i}$$

and

$$I_w = \frac{V_1}{R_0} \quad \text{Hence} \quad I_m = \sqrt{I_0^2 - I_w^2} \quad \dots(5.19)$$

and

$$X_0 = \frac{V_1}{I_m}$$

Therefore, R_0 and X_0 can be obtained from the observations of the no load test.

To find out R_1 , X_1 , R_2 and X_2 parameters of the transformer we perform what is known as short circuit test which is described in the next article.

5.8 SHORT-CIRCUIT TEST

As the name suggests one of the windings would be short circuited and across the other winding supply would be connected.

The connection diagram is as shown in Fig. 5.13.

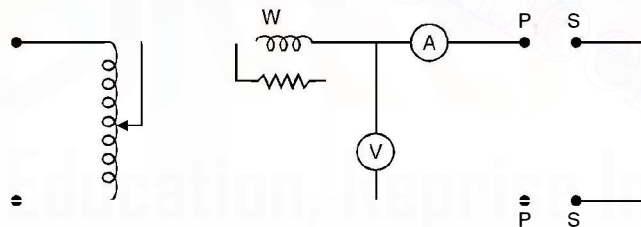

Fig. 5.13. Connection diagram for S.C. Test.

The equivalent circuit of the transformer under short circuit condition is shown in Fig. 5.14.

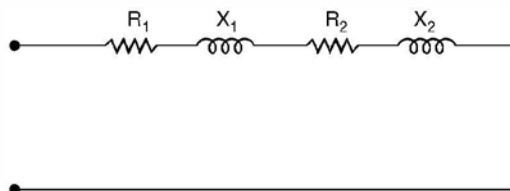

Fig. 5.14. Equivalent circuit of transformer under S.C. condition.

Here the shunt branch is omitted as the current drawn by the shunt I_0 is negligibly small as compared to full load current and when short circuit is carried out the requirement is that the supply voltage should be such that rated current flows in the two windings. Now if rated voltage is supplied, the current is limited by the series impedances and the short circuit current is found to be as high as ten times the full load current which will overheat both the windings, and insulation of the windings will be damaged and hence it is required to make measurements with such a reduced voltage that rated currents circulate in the two windings and with this voltage which is approximately $\frac{1}{10}$ th of the rated voltage I_0 is going to be $\frac{1}{10}$ th of what it would be when rated voltage is applied and hence the shunt branch can be eliminated from the equivalent circuit.

The short circuit test is most conveniently made by short-circuiting the LT winding, for this means that the current to be measured will be the moderate amount corresponding to full load on the HT side and at the same time the voltage to be supplied will be only a small fraction of the normal voltage of the HT winding, therefore, within the range of meters normally available in the testing laboratories.

While selecting ranges of the various meters, following points must be kept in mind. The range of the ammeter should be slightly higher than the full load current of the transformer on HT side, the voltmeter should be such that its range is about 10% of the rated voltage of the transformer on HT side and the voltage and current ratings of the wattmeter should correspond to the voltmeter and ammeter ratings. Since the p.f. of the transformer is low under short circuit as p.f. angle θ_{sc} is given by $\tan^{-1} \frac{X_1 + X_2}{R_1 + R_2}$ and since this ratio is normally more than 4, the p.f. angle is large and hence p.f. is low, a low p.f. wattmeter should be used.

Suppose the readings of the meters are P_c , V and I , the parameters can be obtained as follows. It is to be noted that under the testing conditions since the voltage applied is about $\frac{1}{10}$ th of rated voltage, the iron loss is negligible as these losses are approximately proportional to square of the voltage and hence the wattmeter records mainly the copper losses and hence suffix c is attached to P to indicate that the losses recorded are copper loss predominantly.

$$\begin{array}{l} \text{Now} \\ \text{or} \end{array} \quad \begin{array}{l} I^2(R_1 + R_2) = P_c \\ R_1 + R_2 = \frac{P_c}{I^2} \end{array} \quad \dots(5.20)$$

$$\begin{array}{l} \text{Also} \\ \text{and hence} \end{array} \quad \begin{array}{l} Z = \frac{V}{I} \\ X_1 + X_2 = \sqrt{Z^2 - (R_1 + R_2)^2} \\ \cos \theta_{sc} = \frac{P_c}{VI} \end{array}$$

It is to be noted with caution that since the measurements have been made on the HT side of the transformer, $(R_1 + R_2)$ and $(X_1 + X_2)$ represent the total resistance and reactance respectively of the transformer when referred to HT side. Similarly R_0 and X_0 as measured using O.C. test are the quantities referred to LT side of the transformer. If subscript 1 stands for the LT and 2 for the HT side, here R_1 means the resistance of the LT side when referred to HT side.

In order to study the performance of the transformer *i.e.* voltage regulation and efficiency, we need to know the equivalent resistance and reactance. However, if we want to find out resistance and reactance of individual winding following procedure is usually adopted.

The resistance of individual winding can be obtained by applying low dc voltage such that rated current flows in the corresponding winding and with the help of ammeter and voltmeter readings, the resistance of the winding can be obtained and using equation (5.20)

$$X_1 + X_2 = \sqrt{Z^2 - (R_1 + R_2)^2} \quad \dots(5.21)$$

where R_1 is the resistance of LT winding referred to HT side. Again using equation (5.18) and the above equation X_1 and X_2 can be obtained. Sometimes approximate value of X_1 and X_2 are each taken half of the value obtained from equation (5.21).

It is to be noted that the values of R_1 and R_2 as obtained through SC test are slightly higher than the actual values whereas X_1 and X_2 are slightly lesser than the actual values. However, the values obtained provide sufficiently accurate results from engineering considerations and are used to study the performance of the transformer.

Fig. 5.15 shows phasor diagram of the transformer under short circuit condition.

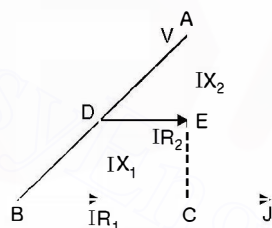

Fig. 5.15. Phasor diagram under SC condition.

Here V is the impressed voltage and I is the current in the winding. Since DE is parallel to BC

$$\frac{R_2}{R_1 + R_2} = \frac{X_2}{X_1 + X_2}$$

or

$$\frac{R_1 + R_2}{R_2} = \frac{X_1 + X_2}{X_2} \quad \text{or} \quad \frac{R_1}{R_2} = \frac{X_1}{X_2}$$

as given in equation 5.18.

Next we study the performance of the transformer in terms of voltage regulation and efficiency.

5.9 VOLTAGE REGULATION

When a transformer is supplied at a constant voltage and frequency, the secondary voltage keeps on changing depending upon the loading condition. If there is no load, the secondary terminal voltage corresponds to the induced voltage and as we load the transformer, the secondary voltage changes depending upon the load and its p.f. Fig. 5.16 shows the equivalent circuit of the transformer under inductive and capacitive loading conditions and Fig. 5.17 shows the corresponding phasor diagrams for the two loading conditions.

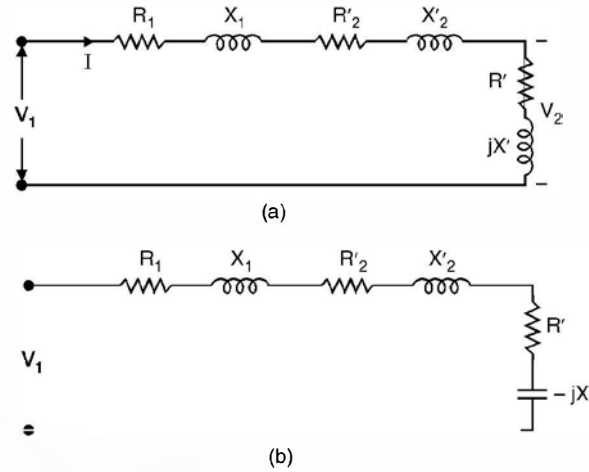

Fig. 5.16. (a) Equivalent circuit for inductive loading
(b) Equivalent circuit for capacitive loading.

To draw the phasor diagrams for the two loading conditions we take V_1 fixed and since it is a series circuit we take I as the reference phasor. In the inductive circuit I lags V_1 by say an angle α and in capacitive circuit I leads V_1 by an angle β .

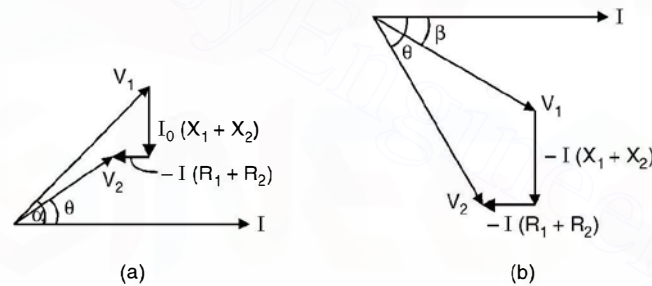

Fig. 5.17. Phasor diagram for (a) inductive load (b) capacitive load.

In both the phasor diagrams, the secondary voltage V_2 is obtained after subtracting the drops due to $I(R_1 + R_2)$ and $I(X_1 + X_2)$ from the supply voltage V_1 and we find that in case of inductive load the magnitude of secondary voltage is less than the supply voltage and for capacitive loads it is otherwise.

Voltage regulation of a transformer for a particular load is defined as the change in secondary voltage from the no load to the load under consideration expressed as a ratio of the rated voltage of the load. If E_2 in the rated secondary terminal voltage and V_2 is the secondary terminal voltage for a particular load, then percentage regulation is expressed as $\frac{E_2 - V_2}{V_2} \times 100$ keeping the primary voltage magnitude and frequency fixed.

Please note that $V_1 \approx E_1$ and E_2 when referred to primary side $E_2 = E_1$

Let us develop an expression for voltage regulation making use of the phasor diagram for the inductive load

$$\begin{aligned}
 & V_1 \cos \alpha = V_2 \cos \theta + I(R_1 + R_2) \text{ and } V_1 \sin \alpha = V_2 \sin \theta + I(X_1 + X_2) \\
 \text{Let } & R_1 + R_2 = R \text{ and } X_1 + X_2 = X \\
 \text{Hence } & V_1^2 \cos^2 \alpha = (V_2 \cos \theta + IR)^2 \\
 \text{and } & V_1^2 \sin^2 \alpha = (V_2 \sin \theta + IX)^2 \\
 \text{or } & V_1^2 = V_2^2 + 2IRV_2 \cos \theta + 2V_2IX \sin \theta + I^2(R^2 + X^2) \quad \dots(5.22) \\
 \text{or } & V_1 = V_2 \sqrt{1 + \frac{2IR}{V_2} \cos \theta + \frac{2IX \sin \theta}{V_2} + \frac{I^2}{V_2^2} (R^2 + X^2)} \quad \dots(5.22 A)
 \end{aligned}$$

Normally rated load voltage V_2 is known, the parameter of transformer R and X are known and p.f. $\cos \theta$ of the load is also known, hence V_1 can be calculated and then

$$\% \text{ regulation} = \frac{V_1 - V_2}{V_2} \times 100 \quad \dots(5.23)$$

From equation (5.22 A) exact value of regulation can thus be obtained. However, in practice the last term under the square root sign in equation 5.22 is generally negligible, therefore

$$V_1 = V_2 \left\{ 1 + \left(\frac{2IR}{V_2} \cos \theta + \frac{2IX}{V_2} \sin \theta \right) \right\}^{1/2} \quad \dots(5.24)$$

Further simplification can be made as the terms within the simple brackets is small as compared to unity and hence using binomial expansion and limiting only to second term

$$\begin{aligned}
 & V_1 \simeq V_2 + IR \cos \theta + IX \sin \theta \\
 \text{or } & \text{regulation} = \frac{V_1 - V_2}{V_2} = \frac{IR}{V_2} \cos \theta + \frac{IX}{V_2} \sin \theta \quad \dots(5.25)
 \end{aligned}$$

The quantity $\frac{IR}{V_2} = V_r$ is dimensionless and is known as per unit resistance of the transformer. Similarly $\frac{IX}{V_2} = V_x$ is the per unit reactance of the transformer. Equation (5.25) has been derived for an inductive load where θ is positive and hence $\sin \theta$ is positive. However, for a capacitive load θ is negative and hence $\sin \theta$ is negative and hence, the general expression for regulation is given by equation as follows

$$\text{regulation} = \frac{IR}{V_2} \cos \theta \pm \frac{IX}{V_2} \sin \theta \quad \dots(5.26)$$

where plus sign is to be used for inductive load and minus sign for a capacitive load.

From the equation 5.26 it is seen that the voltage regulation of a transformer can be zero if the load is capacitive and the p.f. angle θ is such that

$$\begin{aligned}
 & \frac{IR}{V_2} \cos \theta - \frac{IX}{V_2} \sin \theta = 0 \\
 & R \cos \theta = X \sin \theta \\
 \text{or } & \frac{\sin \theta}{\cos \theta} = \frac{R}{X} \\
 \text{or } & \theta = \tan^{-1} \frac{R}{X} \quad \dots(5.26 A)
 \end{aligned}$$

and the p.f. is leading.

In fact the voltage regulation would be negative if the p.f. is leading and it is such that

$$X \sin \theta > R \cos \theta$$

or
$$\theta > \tan^{-1} \frac{R}{X} \quad \dots(5.26 \text{ B})$$

If p.u. resistance and reactance of a transformer are given instead of ohmic values, the expression for voltage regulation is given as

$$\text{p.u. voltage regulation} = V_r \cos \theta \pm V_x \sin \theta \quad \dots(5.27)$$

Example 5.5. A 5 kVA transformer has a nominal voltage rating of 1100/110 volts. With the low voltage winding short circuited, it is found that 33 volts is required to circulate rated full load current and the corresponding power input is 85 watts. Determine the per cent voltage regulation when the load takes rated current at 0.8 p.f. lagging.

Solution. The full load current = $\frac{5 \times 1000}{1100} = 4.55$

Since the supply is connected to HT side we will refer all quantities to HT side

$$I^2(R_1 + R_2) = P_c = 85$$

$$4.55^2 R = 85 \text{ or } R = 4.1 \Omega$$

and
$$Z = \frac{V}{I} = \frac{33}{4.55} = 7.25 \Omega$$

or
$$X = \sqrt{7.25^2 - 4.1^2} = \sqrt{35.8} = 5.96 \Omega$$

Using equation 5.22

$$V_1^2 = V_2^2 + 2V_2IR \cos \theta + 2V_2IX \sin \theta + I^2(R^2 + X^2)$$

$$1100^2 = V_2^2 + 2V_2 \times 4.55 \times 0.8 \times 4.1 + 2V_2 \times 4.55 \times 5.96 \times 0.6 + 4.55^2(4.1^2 + 5.96^2)$$

$$= V_2^2 + V_2(29.85 + 32.54) + 52.56$$

$$1210000 = V_2^2 + 62.4V_2 + 52.56$$

or
$$V_2^2 + 62.4V_2 - 1210000 = 0 \text{ neglecting } 52.56$$

$$V_2 = \frac{-62.4 \pm \sqrt{3893 + 4840000}}{2}$$

$$= \frac{-62.4 \pm 2200}{2} = 1068.8 \text{ volt}$$

Hence percent regulation $\frac{(1100 - 1068.8) \times 100}{1068.8} = 2.9\%$

Alternatively using approximate expression (5.25) for the regulation

$$\left(\frac{IR}{V_2} \cos \theta + \frac{IX}{V_2} \sin \theta \right) \times 100 = \left(\frac{4.55 \times 4.1 \times 0.8}{1068.8} + \frac{4.55 \times 5.96 \times 0.6}{1068.8} \right)_{100}$$

$$= (0.01396 + 0.01522) 100 = 2.9\% \quad \text{Ans.}$$

The two formulae give almost the same voltage regulation. Voltage regulation sometimes is also defined as

$\frac{E_2 - V_2}{E_2}$ where E_2 is the rated secondary voltage. In that case for the above problem regulation comes out to be

$$(1100 - 1068.8)/1100 = 2.84\%$$

Example 5.6. Determine the regulation of a transformer in which ohmic loss is 1% of the output and the reactance drop 5% of the voltage when p.f. is

(a) 0.8 lag (b) unity (c) 0.8 lead.

Solution. Since ohmic loss is 1% of the output

$$i.e. \quad \frac{I^2 R}{VI} = 0.01 \quad \text{or} \quad \frac{IR}{V} = 0.01$$

and reactance drop is 5% of the voltage

$$i.e. \quad IX = 0.05 V \quad \text{or} \quad \frac{IX}{V} = 0.05$$

(a) Using equation 5.25 for percent regulation we have

$$\% \text{ regulation} = \left(\frac{IR}{V} \cos \theta \pm \frac{IX}{V} \sin \theta \right) 100$$

For 0.8 lag p.f. taking plus sign we have

$$(0.01 \times 0.8 + 0.05 \times 0.6) 100 = 3.8\%$$

(b) For unity p.f. $\sin \theta = 0$ Hence

$$\begin{aligned} \% \text{ regulation} \frac{IR}{V} 100 &= 0.01 \times 1 \times 100 \\ &= 1\% \end{aligned}$$

(c) For 0.8 p.f. lead $\sin \theta = -0.6$ Hence

$$(0.01 \times 0.8 - 0.05 \times 0.6) 100 = -2.2\% \quad \text{Ans.}$$

5.10 LOSSES IN A TRANSFORMER

Transformer being a static device, the friction and windage losses are absent. There are mainly two types of losses in a transformer as mentioned earlier (i) Copper loss and (ii) Core loss or iron loss. Iron loss is further divided into two (a) hysteresis loss and (b) eddy current loss.

(i) **Copper loss.** This is due to the flow of current through the conductors of the winding i.e. it is an ohmic loss $I^2 R$ where R is the resistance of the conductor. In addition to this, there is loss caused by nonuniform distribution of the current density in the conductors. This nonuniformity may be considered due to the flow of eddy currents superimposed upon the theoretically uniform current density (assuming I to be flowing uniformly across the section of the conductor of the winding) which of itself would cause the pure ohmic loss.

(ii) (a) **Hysteresis loss.** This is caused by similar to molecular friction as the ultimate particles of the core tend to align themselves first in one direction, then in the other, as the magnetic flux alternates periodically as shown in Fig. 5.18. The area of the loop ABCDEA

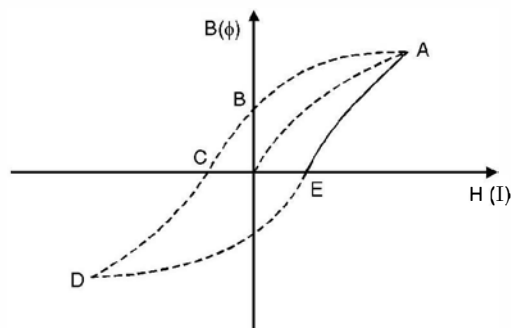

Fig. 5.18. B-H curve.

represents loss in one cycle of variation of ac current. The curve is known as B-H curve. The larger the value of permeability (μ) the smaller is the loop and hence smaller the hysteresis loss in the core. Also hysteresis loss is proportional to frequency of supply and proportional to B^x where x varies between 1.5 and 2. So smaller the B the lower will be the hysteresis loss. However from transformer emf equation, for certain operating voltage if B is low the area of cross section of the core should be large. It is really a design problem and is out of the scope of this book. Normally silicon steel is used for the core material.

- (b) **Eddy current loss.** The alternating flux due to alternating current flowing through the winding induces voltage in the stampings (laminations) of the core just as it does in the coil of the windings. This voltage circulates current in the stampings in the form of eddies. These currents, therefore, heat the stampings and results in power loss. This is known as eddy current loss. The eddy current loss is proportional to $B^2 f^2 t^2$ where t is the thickness of the stampings. The smaller the thickness, the lower the eddy current losses. This is why the core is laminated so as to reduce the eddy current loss. The thickness is usually 0.5 mm.

5.11 EFFICIENCY OF TRANSFORMER

The efficiency of a transformer is defined as the ratio of output power to input power and is denoted by η i.e.

$$\% \eta = \frac{\text{output power} \times 100}{\text{Input power}} = \frac{\text{output} \times 100}{\text{output} + \text{loss}} = \frac{(\text{Input} - \text{loss}) 100}{\text{Input}} \quad \dots(5.28)$$

The losses in the transformer have already been discussed in the previous article. Since transformer is a static device it does not have rotational and windage loss and hence the efficiency of a transformer, in general, is very high, being higher in units of larger units than in smaller units.

The expression for efficiency of a transformer is given as

$$\eta = \frac{V_2 I_2 \cos \theta_2}{V_2 I_2 \cos \theta_2 + P_i + P_c} \quad \dots(5.29)$$

where $V_2 I_2 \cos \theta$ is the output power, P_i the constant iron loss and P_c the variable copper loss. P_i is constant as the supply voltage is constant rated voltage and P_c the copper loss is variable

depending upon the loading condition. If the load is zero, P_c is practically zero however iron losses are taking place and are constant under no load condition, the output is zero and input corresponds to iron loss and hence efficiency is zero. Assuming V_2 to remain constant over certain loading condition, with increase in load, I_2 increases and hence for certain p.f. of load, the output increases and the copper loss also increases, the iron loss remains constant corresponding to no load loss, the efficiency increases. It will be shown shortly that when the loading is such that $P_i = P_c$ the efficiency is maximum and if we increase the load further $P_c > P_i$ and the increase in output is not as much as the increase in copper loss, as a result the efficiency decreases. The variation of efficiency as a function of loading is shown in Fig. 5.17.

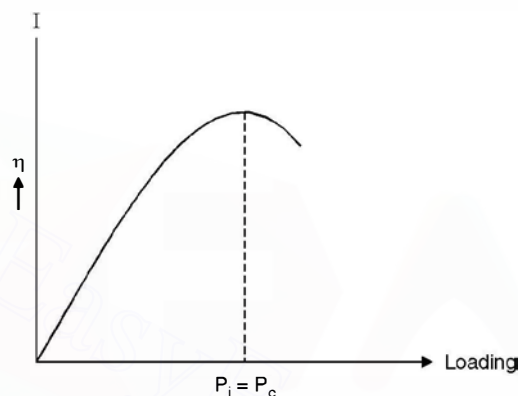

Fig. 5.19. Efficiency V_s loading.

For a certain p.f. of the load, the increase in load means effective decrease in the load impedance. In fact when the effective impedance is zero which means the secondary is short circuited, again the output is zero, even though there is substantial increase in current ; the secondary voltage is zero and hence output is zero and the complete input goes as iron and copper losses and the efficiency is zero. Please note that the efficiency of the transformer under no load and short circuit conditions is zero. Let us find out the loading condition for which the efficiency is maximum. Let P be the full load power and x be the fraction of full load for which the efficiency is maximum. Assuming secondary voltage to remain constant over the range of consideration of loading, the iron losses remain P_i whereas copper loss will become $x^2 P_c$ where P_c is the copper loss corresponding to full load. Hence

$$\eta = \frac{xP}{xP + P_i + x^2 P_c} = \frac{P}{P + \frac{P_i}{x} + xP_c} \quad \dots(5.30)$$

For efficiency to be maximum $\frac{P_i}{x} + xP_c$ should be minimum

Let
$$f(x) = \frac{P_i}{x} + xP_c$$

For $f(x)$ to be minimum $f'(x) = 0 = -\frac{P_i}{x^2} + P_c$

$$\text{or } P_c = \frac{P_i}{x^2} \quad \text{or } x^2 P_c = P_i \quad \dots(5.31)$$

$$\text{or } x = \sqrt{\frac{P_i}{P_c}} \quad \dots(5.32)$$

From equation (5.31) it is clear that maximum efficiency occurs at a loading when copper loss equals the iron loss and the loading is given by equation (5.32). Normally the power transformers are so designed that the maximum efficiency occurs some where between 75% to 85% of the full load.

The all day efficiency of a transformer is the ratio of the total energy output (kwhrs) in a 24-hr day to the total energy input during the same time. Since transformers on distribution circuits are connected permanently to the supply line, the core loss goes on continuously, so that it is important to design distribution transformers with low iron loss consistence with other requirements. In general, low core loss means keeping low flux density which can be brought about either by using a relatively large number of turns in the winding or by increasing the cross-section of the core or both ways. The apportionment of the losses as between core loss on the one hand and copper loss on the other is, therefore, of much importance in determining all day efficiency.

Example 5.7. Calculate the values of R_o , X_o , R_i and X_i in the diagram for the equivalent circuit of a single phase 4KVA, 200/400 V 50 Hz transformer of which the following are the test results

O.C. test 200 V, 0.7 A, 70 W on low voltage primary side

S.C. test 15 V, 10 A, 80 W on HT side.

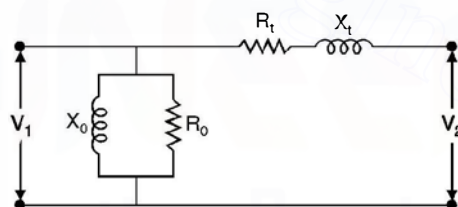

Fig. E5.7

Solution. Using equation (5.19) we have

$$R_o = \frac{V_1^2}{P_i} = \frac{200^2}{70} = 571 \Omega \quad \text{Ans.}$$

$$I_w = \frac{V_1}{R_o} = \frac{200}{571} = 0.35 \text{ A}$$

$$\text{Hence } I_\mu = \sqrt{0.7^2 - 0.35^2} = 0.6 \text{ A}$$

$$\text{Hence } X_o = \frac{V_1}{I_\mu} = \frac{200}{0.6} = 333 \Omega \quad \text{Ans.}$$

Similarly using equation 5.20

$$R_t = \frac{P_c}{I^2} = \frac{80}{10^2} = 0.8 \Omega$$

and

$$Z = \frac{V}{I} = \frac{15}{10} = 1.5 \Omega$$

Hence $X_t = \sqrt{2.25 - 0.64} = 1.269$

R_t and X_t are referred to HT since whereas the equivalent circuit required is on LT side.
Hence

$$R_t(LT \text{ side}) = 0.8 \times \frac{1}{n^2} = 0.8 \times \frac{1}{2^2} = 0.2 \text{ Ans.}$$

Similarly $X_t(LT \text{ side}) = \frac{1.269}{4} = 0.317 \Omega \text{ Ans.}$

Example 5.8. Fig E 5.8 shows the equivalent circuit for a 1-phase transformer. Fig. gives resistance and reactance in ohms in terms of the primary side. The ratio of secondary to primary turns is 10. Determine (a) the secondary terminal voltage (b) the primary current (c) the efficiency.

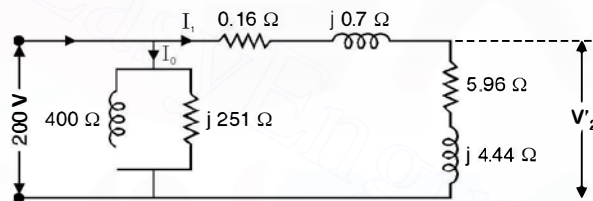

Fig. E 5.8.

Solution. We solve the circuit as referred to primary side.

$$I_1 = \frac{200}{(5.96 + 0.16) + j 5.14} = \frac{200}{6.12 + j 5.12} = \frac{200}{7.979 / 39.9}$$

$$= 25.06 / -39.9^\circ$$

$$I_w = \frac{200}{400} = 0.5 \text{ A and } I_\mu = \frac{200}{j 251} = -j 0.797$$

Hence primary current = $0.5 - j 0.797 + 19.22 - j 16.07$

$$= 19.72 - j 16.867 = 25.95 / -40.3 \text{ Ans.}$$

Now current $I_1 = 25.06 / -39.9$

and load impedance is $5.96 + j 4.44$

$$= 7.43 / 36.68^\circ$$

Hence secondary terminal voltage referred to primary side is $25.06 \times 7.43 / -3.22 = 186.2 / -3.22$ volts .

Hence actual secondary terminal voltage 186.2×10

$$= 1862 \angle -3.22^\circ \quad \text{Ans.}$$

Now output power $= 25.06^2 \times 5.96 = 3743$ watts

$$\text{Iron loss} = \frac{V_1^2}{R_\bullet} = \frac{200^2}{400} = 100 \text{ watts}$$

Copper loss $25.06^2 \times 0.16 = 100.48$ watts

$$\text{Hence efficiency} = \frac{3743 \times 100}{3743 + 100 + 100.48} = 94.9\% \quad \text{Ans.}$$

Example 5.9. *The maximum efficiency of a 500 KVA, 3300/500 V 50 Hz single phase transformer is 97% and occurs at $\frac{3}{4}$ full load unity p.f. If the impedance is 10%. Calculate the regulation at full load, p.f. 0.8 lag.*

Solution. The output at $\frac{3}{4}$ th full load unity p.f. is

$$500 \times 1 \times \frac{3}{4} = 375 \text{ kW}$$

Since at maximum efficiency iron loss equals copper loss, let each be x kW, hence

$$0.97 = \frac{375}{375 + 2x}$$

or

$$375 + 2x = 386.6$$

or

$$x = 5.8 \text{ kW}$$

The load current at maximum efficiency

$$\frac{375 \times 1000}{500} = 750 \text{ A}$$

$$\text{Hence } R = \frac{5.8 \times 1000}{750^2} = 0.0103$$

Now full load current is $\frac{500 \times 1000}{500} = 1000 \text{ A}$

$$\text{Hence percent resistance} = \frac{1000 \times 0.0103}{500} \times 100 = 2.06$$

$$\text{Hence percent reactance} = \sqrt{10^2 - 2.06^2} = \sqrt{95.76} = 9.78$$

Hence percent regulation

$$\begin{aligned} & 2.06 \times 0.8 + 9.78 \times 0.6 \\ & = 1.648 + 5.87 = 7.51\% \quad \text{Ans.} \end{aligned}$$

Example 5.10. *In a 25 KVA 2000/200 V transformer the iron and copper losses are 350 and 400 W respectively. Calculate the efficiency on unity p.f. at (a) full load and (b) half load (c) Determine the load for maximum efficiency and the iron and copper loss in this case.*

Solution. The copper loss at full load given is 400 W

$$\text{Hence (a)} \quad \% \eta = \frac{25000 \times 1 \times 100}{25000 + 350 + 400} = 97.08\%$$

$$\text{(b) At halfload} \quad P_i = 350 \text{ watts } P_c = \frac{400}{2^2} = 100 \text{ watt}$$

$$\text{Hence} \quad \% \eta = \frac{12500 \times 1 \times 100}{12500 + 100 + 350} = 96.52\%$$

$$\text{(c) The load at which maximum efficiency will occur} = \sqrt{\frac{350}{400}} \times 25 \text{ KVA} = 23.38 \text{ KVA} \quad \text{Ans.}$$

and the losses are each 350 watt. **Ans.**

Example 5.11. Calculate the efficiencies at half, full and $1\frac{1}{4}$ load of a 100 KVA transformer for p.f. of (a) unity (b) 0.8. The copper loss is 1000 watt at full load and the iron loss is 1000 watts.

Solution. (a) Unity p.f.

$$\text{(i) Half full load} \quad = \frac{100}{2} \times 1 = 50 \text{ kW}$$

$$\text{Copper loss at } \frac{1}{2} \text{ load} \quad = \frac{1000}{4} = 250$$

$$\text{Iron loss} \quad = 1000 \text{ watts}$$

$$\text{Hence} \quad \% \eta = \frac{50000 \times 100}{50000 + 1000 + 250} = 97.56\%$$

$$\text{(ii) Full load} \quad \% \eta = \frac{100000 \times 100}{1000 + 1000 + 100000} = 98.04\%$$

$$\text{(iii) At } \frac{5}{4} \text{ full load copper loss} = 1000 \times \frac{25}{16} = 1562 \text{ watt}$$

$$\frac{100000 \times \frac{5}{4} \times 100}{125000 + 1000 + 1562} = 97.99\%$$

(b) 0.8 p.f.

$$\text{(i) Half full load output} = \frac{100}{2} \times 0.8 = 40 \text{ kW}$$

$$\% \eta = \frac{40000 \times 100}{40000 + 1000 + 250} = 96.96\%.$$

Example 5.12. A transformer has its maximum efficiency of 0.98 at 15 KVA at unity p.f. During the day it is loaded as follows :

12 hrs – 2 kW at p.f. 0.5

6 hrs – 12 kW at p.f. 0.8

6 hrs – 18 kW at p.f. 0.9

Determine the all day efficiency.

Solution. To find copper and iron loss

$$0.98 = \frac{15 \times 1}{15 \times 1 + 2x} \text{ where } x \text{ is iron loss and also copper loss at 15 KVA loading}$$

$$15 + 2x = 15.306$$

or $x = 153 \text{ watts}$

Iron loss for 24 hrs are 153 watts

Copper loss, however, depend upon loading

During first 12 hrs when load is 2 kW at 0.5 p.f. *i.e.*

$$\begin{aligned} \text{the KVA is 4 and hence copper loss} &= 153 \times \left(\frac{4}{15}\right)^2 \\ &= 10.88 \text{ Watts} \end{aligned}$$

$$\text{During next 6 hrs} \quad 153 \times \left(\frac{15}{15}\right)^2 = 153 \text{ watts}$$

$$\text{and During next 6 hrs} \quad 153 \times \left(\frac{20}{15}\right)^2 = 272 \text{ watts}$$

$$\begin{aligned} \text{Hence } \% \eta &= \frac{(12 \times 2 + 6 \times 12 + 6 \times 18) \times 100 \times 1000}{12 \times 10.88 + 6 \times 153 + 6 \times 272 + 24 \times 153 + 204 \times 1000} \\ &= \frac{(24 + 72 + 108) 1000 \times 100}{130.56 + 918 + 1632 + 204 \times 1000} \\ &= \frac{204 \times 1000}{206681} \times 100 = 97.5\%. \end{aligned}$$

5.12 POLARITY OF A TRANSFORMER

Refer to Fig. 5.20. Whenever the primary of a transformer is connected to a c source the potentials of the terminals A_1 , A_2 and a_1 , a_2 keep on varying. Sometimes A_1 is positive, at that time A_2 would be negative. Similar is the variation at terminals a_1 and a_2 . At another time A_1 if is negative A_2 would be positive.

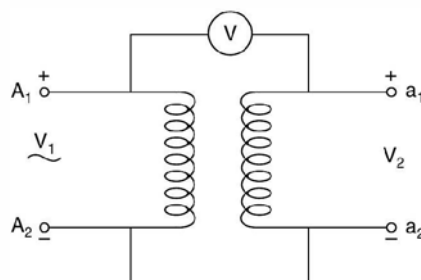

Fig. 5.20. Polarity testing.

So, the phrase polarity of a transformer appears to be vague. What we are interested here is to know the instantaneous polarities of the terminals A_1 , A_2 , a_1 and a_2 i.e. if at any instant of time A_1 is positive what are the polarities of A_2 , a_1 and a_2 . Sometimes even A_1 , A_2 , a_1 and a_2 are not marked on the body of the transformer. How to mark the polarities of the terminals. In case, the terminal marking is not there, we might arbitrarily mark these terminals and make connections as shown in Fig. 5.20. Suppose it is a step down transformer i.e. $V_1 > V_2$ and if the voltmeter reads $V = V_1 - V_2$ the polarities of the four terminals will be as indicated in Fig. 5.20. However, if $V = V_1 + V_2$ (Therefore, the range of the voltmeter should be at least equal to $(V_1 + V_2)$) retaining the polarities of A_1 and A_2 as in Fig. 5.20, the polarities of a_1 should be negative and that of a_2 as positive. The first type of connection is known as subtractive polarity as $V = V_1 - V_2$ as shown in Fig. 5.20 and the other type is known as additive polarity as $V = V_1 + V_2$.

The knowledge of polarities of the transformer is very important whenever two or more than two transformers are to be interconnected e.g. parallel operation of two or more transformers when one transformer is not sufficient to supply certain amount of load or three single phase transformer to be connected as three phase transformers.

If the polarities of the two transformers to be connected in parallel are known it is easy to connect them in parallel as shown in Fig. 5.21.

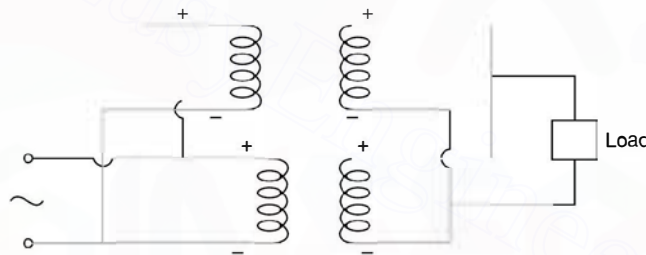

Fig. 5.21. Parallel connection of two transformers.

However, if the polarities are not known following procedure is used which again involves knowledge of polarities. Refer to Fig. 5.22 connect the primaries in parallel arbitrarily

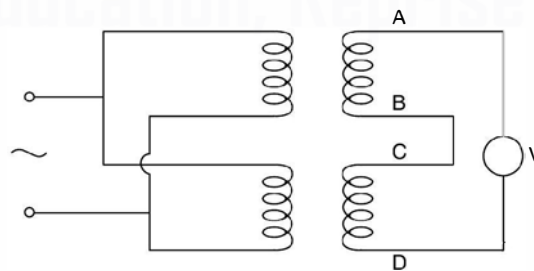

Fig. 5.22. Procedure for parallel connection of two transformers.

without caring for the polarities. Short two secondary winding terminals of the two transformers arbitrarily as shown in Fig. 5.22 (B and C) and connect a voltmeter across the other two secondary terminals A and D as in Fig. 5.22. If the voltmeter reads zero, remove the voltmeter

and short circuit A and D and connect the load between A and B or C or between B or C and D. However, if voltmeter reads two times the secondary voltage of each transformer, the polarities are additive and hence B and D should be shorted and voltmeter to be connected across A and C and we will see that the voltmeter now reads zero, the polarities are subtractive *i.e.*, the two secondaries are connected in opposition.

If three single phase transformers are to be used as a single three phase transformer, following procedure is used. Mark polarities of the three transformers as explained earlier. Say the polarities are as shown in Fig. 5.23.

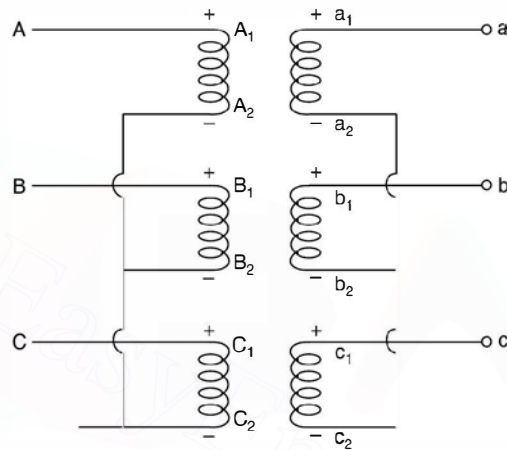

Fig. 5.23. Star-star (Y/Y) connection.

To make star-star connection, the three negative terminals of the primary are shorted to make neutral of the star connection and the remaining three positive polarity terminals form the phase terminal. Similar procedure is followed for the secondaries. In order to make delta/delta connection, the negative terminal A_2 is connected to positive terminal B_1 and B_2 is connected to C_1 and A_1 is connected to C_2 and the common terminals are brought out to form phase terminals as shown in Fig. 5.24.

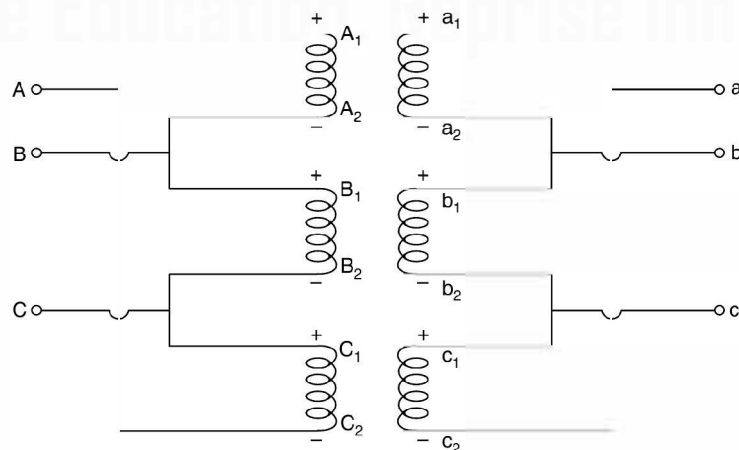

Fig. 5.24. Delta/delta Δ/Δ connection.

The relations between phase and line quantities (voltage and current) for star and delta connections have already been discussed in Chapter 3.

For transmission of power normally star/star transformers are used whereas for distribution where single phase loads are also to be taken care of delta/star transformers are used.

5.13 TESTING OF TRANSFORMERS

Following tests are usually carried out on a transformers :

1. O.C. test or No load test
2. S.C. test
3. Direct loading of the transformer
4. Indirect loading or artificial loading or phantom loading or Sumpner's test.

The O.C. test and S.C. tests have already been discussed in detail. Direct loading is carried out for obtaining efficiency, regulation and temperature rise of the transformer windings. Direct loading means the transformer is to be loaded to its rated capacity for specified number of hours to find out temperature rise. Hence, this method of testing is normally not recommended especially for large capacity transformers as it involves huge amount of energy to be wasted only for testing of the transformer.

The indirect method or phantom loading method requires only iron and copper losses to be supplied corresponding to full load and still temperature rise corresponding to rated capacity of the transformer can be obtained. The only drawback is that it requires an additional and identical transformer for the transformer to be tested.

5.13.1 Sumpner's Test

Refer to Fig. 5.25. As mentioned, we need an additional identical transformer and the two transformers are connected in parallel (subtractive polarity) as shown in Fig. 5.25. Voltmeter connected across AD should read zero. Once this condition is achieved a single phase variable low voltage source is connected across AD. The voltage is so adjusted that rated current circulates in the two secondaries of this transformer. The voltage required is low as the impedance offered by the secondaries is only the short circuit impedances in series *i.e.* R_1' , X_1' and R_2 and X_2 in series. These secondary currents are reflected in the primary as shown by dotted line and these currents circulate in the primary windings only and these do not appear on the line side of the primary windings. The current in the two windings corresponds to rated current ; hence it is as though the transformer were fully loaded and, therefore, it is known as phantom loading. The current is circulated for a specified number of hours and temperature rise of the winding is recorded.

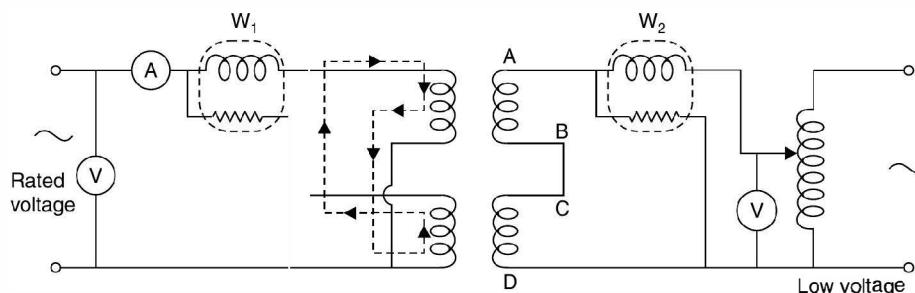

Fig. 5.25. Sumpner's test.

Example 5.13. Two similar 200 KVA 1-phase transformers gave the following results when tested by the Sumpner's test (Back to back Test) method : W_1 in the supply line 4 kW, W_2 in the secondary series circuit, when full load current-circulated through the secondaries 6 kW. Determine the efficiency of each transformer.

Solution. Since W_1 reads the total iron loss for both the transformers and W_2 the total copper loss for both the transformers, the iron and copper loss for each transformer is $\frac{4}{2} = 2$ kW and $\frac{6}{2} = 3$ kW respectively. Hence efficiency of each transformer at full load is

$$\% \eta = \frac{200}{200 + 2 + 3} \times 100 = 97.56\% \quad \text{Ans.}$$

5.14 AUTO TRANSFORMER

An auto transformer is one in which one single winding serves both as primary and secondary winding as shown in Fig. 5.26.

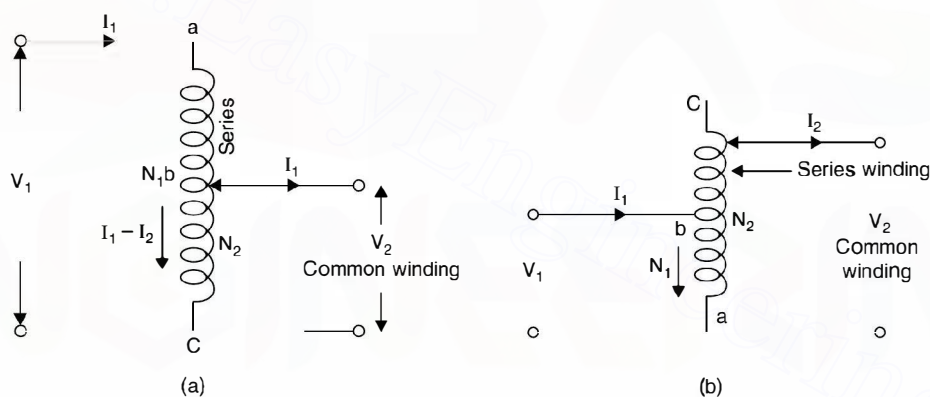

Fig. 5.26. (a) Step down (b) Step up auto transformer.

The winding is divided in two parts, the 'common' winding and the series winding. The 'common' winding is at least a part of both the primary and secondary winding simultaneously.

When ac voltage is supplied across 'a, c' terminals of step down transformer in Fig. 5.26(a), a flux ϕ_m is produced which induces voltage in the primary $E_1 = 4.44 f\phi_m N_1$ and similarly, a voltage $E_2 = 4.44 f\phi_m N_2$ is induced. From these equations

$$\frac{E_1}{E_2} = \frac{N_1}{N_2} = n \quad \text{say} \quad \dots(5.33)$$

Assuming the series impedance drops to be negligible as compared to terminal voltage

$$V_1 \simeq E_1 \quad \text{and} \quad V_2 \simeq E_2$$

Hence

$$\frac{V_1}{V_2} = \frac{E_1}{E_2} = n \quad \dots(5.34)$$

From Fig. 5.26 (a) it is seen that assuming magnetising current to be zero, the ampere-turns of the series winding should equal the negated ampere turns of the common winding *i.e.*

$$I_1 (N_1 - N_2) + (I_1 - I_2) N_2 = 0$$

or

$$I_1 N_1 - I_1 N_2 + I_1 N_2 - I_2 N_2 = 0$$

or

$$I_1 N_1 = I_2 N_2$$

or

$$\frac{I_1}{I_2} = \frac{N_2}{N_1} = \frac{V_2}{V_1} = \frac{1}{n} \quad \dots(5.36)$$

or

$$V_1 I_1 = V_2 I_2 \quad \dots(5.37)$$

The consequences of equation (5.36) with respect to step down and step up transformer will now be considered.

(a) **Step down auto transformer.** The volt amperes delivered to the load (From Fig. 5.26a) are given as

$$P = V_2 I_2$$

which can be rewritten as

$$V_2 I_2 = V_2 I_1 + V_2 (I_2 - I_1) \quad \dots(5.38)$$

The first part $V_2 I_1 = P_c$ represents volt amperes conductivity transferred to the load through *ab*, the series winding, and the second term $V_2 (I_2 - I_1) = P_i$ represents the volt-amperes inductively transferred to the load through *bc*, the common winding.

We now find the ratio of the inductively transferred power to the total power transferred.

$$\frac{\text{Inductively transferred power}}{\text{Total power}} = \frac{P_i}{P}$$

$$= \frac{1/2 (I_2 - I_1) V_2}{V_2 I_2} = \frac{I_2 - I_1}{I_2} = 1 - \frac{I_1}{I_2}$$

$$= 1 - \frac{1}{n} \quad \dots(5.39)$$

$$= 1 - \frac{V_2}{V_1} = \frac{V_1 - V_2}{V_1} \quad \dots(5.40)$$

and

$$\frac{P_c}{P} = \frac{V_2 I_1}{V_2 I_2} = \frac{I_1}{I_2} = \frac{1}{n} = \frac{V_2}{V_1}$$

Step up auto transformer : From Fig. 5.26(b), the volt-amperes input to the transformer

$$P = V_1 I_1 = V_1 I_2 + V_1 (I_1 - I_2) \quad \dots(5.41)$$

which means that P consists of two components.

$P_c = V_1 I_2$ = apparent power conductivity transformed through *cb*, the series portion of the winding and

$P_i = V_1 (I_1 - I_2)$ is the inductively transferred power through *ba*, the common portion of the winding.

It is to be noted that the inductively transferred power in both the cases represents the rating of the equivalent two winding transformer

$$\begin{aligned} & \frac{\text{Inductively transferred power}}{\text{Total transferred power}} \\ &= \frac{\text{Output VA of equivalent two winding transformer}}{\text{Output VA of auto transformer}} \\ &= \frac{V_1(I_1 - I_2)}{V_1 I_1} = 1 - n \dots\dots \quad (5.42) \\ &= 1 - \frac{V_1}{V_2} \\ &= \frac{V_2 - V_1}{V_2} \quad \dots(5.43) \end{aligned}$$

Rewriting equation (5.39) as follows :

$$\frac{\text{Output VA of equivalent two winding transformer}}{\text{Output VA of auto transformer}} = 1 - \frac{1}{n} = \frac{n-1}{n}$$

Thus a two-winding transformer connected as a step down auto transformer will have a volt ampere rating $\frac{n}{n-1}$ times its rating as a two winding transformer. This increase becomes

larger as the ratio of transformation n approaches unity but in the limiting case when $n = 1$ the power transferred conductively is equal to the entire input and the power transferred inductively becomes zero which means that there is no need for an auto transformer. On the other hand, if an auto transformer is to be designed for a rating P , it will consist of a two-winding transformer

having a rating $P \cdot \frac{(n-1)}{n}$, which becomes smaller as n approaches unity. When designed in this way the material in the auto transformer will be utilised to the maximum extent.

Comparing equations (5.40) and (5.43) it is found that in both the cases *i.e.* for step down or step up auto transformer the ratio

$$\frac{P_i}{P} = \frac{\text{High voltage} - \text{low voltage}}{\text{High voltage}}$$

is the same.

The disadvantage of an auto transformer is that there is no electrical isolation between the primary and secondary circuits. However, when V_1 and V_2 are both large or of the same order of magnitude as in many applications of the auto transformer, this disadvantage is not of itself objectionable ; but if an auto transformer is used to step up the voltage V_1 of a generator to a higher voltage $V_2 = nV_1$ where $n > 1$ an accidental ground on the high voltage side will subject the generator insulation to a potential stress n times its normal value.

5.14.1 Saving in Copper in Auto Transformer

For the same capacity and voltage ratio the weight of copper required for an auto transformer is less as compared to the two-winding transformer. Now the weight of copper required depends

upon the length of the winding and area of cross section of the conductor used for the winding. However these quantities depend upon the number of turns of the winding and the current carried by the winding respectively *i.e.* it depends upon the number of ampere turns of the windings.

Ampere turns for two winding transformer. Let I_1 and I_2 be the primary and secondary currents and N_1 and N_2 the primary turns and secondary turns. The total no. of ampere turns $I_1N_1 + I_2N_2$.

Ampere turns for an auto transformer. Refer to Fig. 5.26 (a).

Ampere turns between $a b$ $I_1(N_1 - N_2)$

and ampere turns between bc $(I_2 - I_1) N_2$

Total ampere turns $I_1(N_1 - N_2) + (I_2 - I_1)N_2$

Hence ratio of $\frac{\text{weight of copper for auto transformer}}{\text{weight of copper for two winding transformer}}$

$= \frac{I_1(N_1 - N_2) + (I_2 - I_1) N_2}{I_1N_1 + I_2N_2} = \frac{I_1N_1 - I_1N_2 + I_2N_2 - I_1N_2}{I_1N_1 + I_2N_2}$

$$= \frac{I_1(N_1 - 2N_2) + I_2N_2}{I_1N_1 + I_2N_2}$$

Dividing numerator and denominators by I_1N_2 we have

$$= \frac{\frac{N_1}{N_2} - 2 + \frac{I_2}{I_1}}{\frac{N_1}{N_2} + \frac{I_2}{I_1}}$$

since $\frac{N_1}{N_2} = \frac{I_2}{I_1} = n$

we have the ratio as

$$\frac{n - 2 + n}{n + n} = \frac{2n - 2}{2n} = \left(1 - \frac{1}{n}\right)$$

Then the weight of copper required for an auto transformer for the same capacity and voltage ratio is $\left(1 - \frac{1}{n}\right)$ times that required for a two winding transformer where $n > 1$. Thus

saving in copper is to the extent of $\frac{1}{n}$ times the weight of copper in two winding transformer.

If n is close to 1, saving is very large. Thus an auto transformer is more useful for transformation ratio close to 1.

Example 5.14. Determine the ratio of weights of copper in an auto transformer and a two winding transformer if the transformation ratio is 3.

Solution. The ratio is given as $1 - \frac{1}{n}$ where n is the ratio of transformation. Hence for the given example it is $1 - \frac{1}{3} = \frac{2}{3}$ **Ans.**

Example 5.15. A 11500/2300 V transformer is rated at 100 KVA as a 2-winding transformer. If the two windings are connected in series to form an auto transformer. What will be the voltage ratio and output ?

Solution. We will consider only addition polarities of the two windings as the primary and the secondary will be either 11.5 KV winding or 2.3 KV winding.

The two possible connections are :

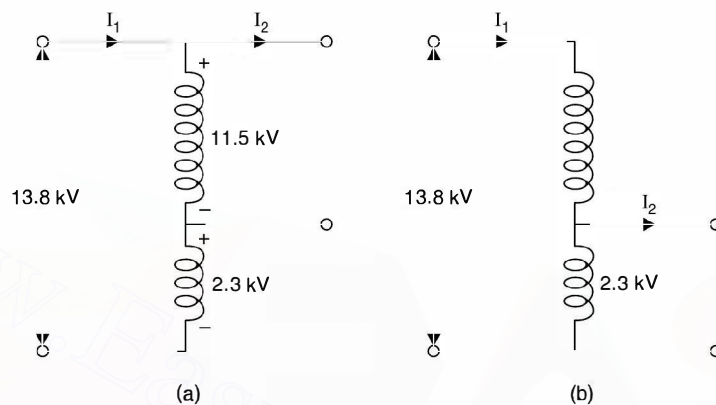

Fig. E5.15

(a) The transformation ratio is

$$\frac{13.8}{11.5} = \frac{6}{5} = 1.2 = n$$

using equation (5.39)

$$\frac{P_i}{P} = 1 - \frac{1}{n}$$

where $P_i = 100$ KVA and $n = \frac{6}{5}$

Substituting

$$\frac{100}{P} = 1 - \frac{5}{6} = \frac{1}{6}$$

or

$$P = 600 \text{ KVA}$$

Therefore, the rating of auto transformer is 13.8/11.5 KV, 600 KVA **Ans.**

(b) The transformation ratio is

$$\frac{13.8}{2.3} = 6$$

Again using equation (5.39) $\frac{P_i}{P} = 1 - \frac{1}{n}$

or
$$\frac{100}{P} = 1 - \frac{1}{6} = \frac{5}{6}$$

or
$$P = 100 \times \frac{6}{5} = 120 \text{ KVA}$$

Therefore, the rating of auto transformer is 13.8/2.3 KV 120 KVA **Ans.**

Example 5.16. A 100Ω source is to be matched to a 40Ω , 2 W load by means of a transformer. What is the turns ratio? Determine the primary and secondary voltages and current.

Solution.

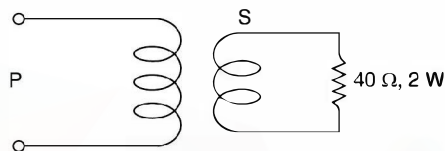

Fig. E5.16

The turns ratio is
$$\frac{n_2}{n_1} = \sqrt{\frac{40}{100}} = 1 : 1.58$$

Secondary voltage
$$= \frac{V_2^2}{40} = 2 \quad \text{or} \quad V_2 = 8.94$$

Hence primary voltage
$$V_1 = 1.58 \times 8.94 = 14.13$$

Secondary current
$$I_2^2 R_2 = I_2^2 \times 40 = 2$$

or
$$I_2 = \sqrt{\frac{1}{20}} = 0.2236 \text{ A}$$

and primary current
$$= \frac{0.2236}{1.58} = 0.1414 \text{ A} \quad \text{Ans.}$$

Example 5.17. Calculate in terms of the primary the equivalent resistance and leakage reactance of a transformer which gave the following data on test with the secondary terminals short circuited :

Applied voltage 60 V , current 100 A , power input 1200 W .

Solution. Since the measurements have been made on the primary side and secondary side short-circuited, the parameters calculated will be, the equivalent resistance and reactance referred to primary side.

$$z = \frac{60}{100} = 0.6 \Omega$$

Since power input in S.C. test corresponds to copper losses, hence

$$I_1^2 R_{leq} = 1200$$

$$\begin{aligned}
 \text{or} \quad & 100^2 R_{leq} = 1200 \\
 \text{or} \quad & R_{leq} = 0.12 \, \Omega \quad \text{Ans.} \\
 \text{Since} \quad & Z_{eq} = 0.6 \\
 & X_{leq} = \sqrt{0.6^2 - 0.12^2} = 0.465 \, \Omega \quad \text{Ans.}
 \end{aligned}$$

Example 5.18. The high and low voltage windings of a 6600/250 V, 50 Hz 1-phase transformer have resistance of $0.21 \, \Omega$ and $2.72 \times 10^{-4} \, \Omega$ and reactances of $1.0 \, \Omega$ and $1.3 \times 10^{-3} \, \Omega$ respectively. Determine the current and power input when the high voltage winding is connected to a 400 V, 50 Hz supply, the low voltage winding being short circuited.

Solution. In case of short circuit test the low voltage winding is always shorted and measurements are made on the HV side with reduced voltage applied across its terminals.

The equivalent resistance on high voltage side is

$$\begin{aligned}
 R_H + R_L \left(\frac{V_H}{V_L} \right)^2 &= 0.21 + 2.72 \times 10^{-4} \times \left(\frac{6600}{250} \right)^2 \\
 &= 0.21 + 0.1896 \\
 &= 0.3996 \, \Omega \simeq 0.4 \, \Omega \quad \text{Ans.}
 \end{aligned}$$

Similarly equivalent reactance on high voltage side

$$\begin{aligned}
 X_H + X_L \left(\frac{V_H}{V_L} \right)^2 &= 1.0 + 1.3 \times 10^{-3} \times \left(\frac{6600}{250} \right)^2 \\
 &= 1.0 + 0.906 \\
 &= 1.906 \, \Omega \simeq 1.9 \, \Omega \quad \text{Ans.}
 \end{aligned}$$

Hence equivalent impedance

$$Z_{H,eq} = \sqrt{1.9^2 + 0.4^2} = 1.94 \, \Omega$$

Hence current on the high voltage side is

$$\frac{400}{1.94} = 206 \, \text{A} \quad \text{Ans.}$$

$$\begin{aligned}
 \text{and power input} \quad &= I_H^2 R_H = 206^2 \times 0.4 \\
 &= 16.97 \simeq 17 \, \text{kW} \quad \text{Ans.}
 \end{aligned}$$

Example 5.19. A 100 KVA, 1000/10000 V 50 Hz transformer has an iron loss of 1200 watts. The copper loss with 6 A in the high voltage winding is 500 W. Determine the efficiency at (i) 25% (ii) 50% and (iii) 100% of normal load at p.f. (a) unity and (b) 0.8, the output terminal voltage being maintained at 10,000 volts. Determine also the load for maximum efficiency at both the p.f.

Solution. The iron losses which are constant irrespective of the loading is given as 1200 W.

The full load current on HV side is

$$\frac{100,000}{10,000} = 10 \text{ A}$$

Since copper losses for 6 A are 500 watts, hence the full load copper losses are

$$\left(\frac{10}{6}\right)^2 \times 500 \simeq 1390 \text{ watts}$$

Copper losses at 50% load

$$\frac{1390}{2^2} = 347.50 \text{ watts}$$

For 25% load $\frac{1390}{4^2} = 86.87 \text{ watts}$

(a) Unity p.f.

The output is $100 \times 1 = 100 \text{ KW}$

$$\% \eta \text{ at 25\% load} = \frac{25 \times 1000 \times 100}{25000 + 1200 + 86.87} = \frac{25000 \times 100}{26286.87} = 95.10\%$$

$$\% \eta \text{ at 50\% load} = \frac{50 \times 1000 \times 100}{50000 + 1200 + 347.5} = 97\% \quad \text{Ans.}$$

$$\% \eta \text{ at 100\% load} = \frac{100 \times 1000 \times 100}{100000 + 1200 + 1390} = 97.47\%$$

(b) 0.8 p.f. VI remaining same, the output power is $VI \cos \theta = 100 \times 0.8 = 80 \text{ KW}$

Full load current will remain same.

Hence % η at 25% load

$$\frac{20 \times 1000 \times 100}{20000 + 1200 + 86.87} = 93.95\%$$

% η at 50% load

$$\frac{40 \times 1000 \times 100}{40000 + 1200 + 347.5} = 96.27\%$$

% η at 100 load

$$\frac{80 \times 1000 \times 100}{80000 + 1200 + 1390} = 96.86\% \quad \text{Ans.}$$

Now maximum efficiency occurs at a loading when copper loss equal iron loss (constant loss). Let x be the per unit of full loading for which the condition is satisfied *i.e.*

$$x^2 P_c = P_i \text{ when } P_c \text{ is full load Copper loss}$$

i.e. $1390x^2 = 1200$

or $x = \sqrt{\frac{1200}{1390}} = 0.929$

Hence the load $0.929 \times 100 \simeq 93 \text{ KVA}$ is the loading for which the efficiency is maximum.

Example 5.20. A transformer has resistance and reactance drops of 2.5% and 5% respectively. Determine the maximum regulation and the power factor at which it occurs.

Solution. The approximate expression for voltage regulation is given as

$$y = v_r \cos \phi + v_x \sin \phi$$

Here v_r and v_x are given to be 2.5% and 5% respectively. Hence

$$y = 2.5 \cos \phi + 5 \sin \phi$$

To find out maximum regulation we differentiate y with respect to ϕ and equate to zero we have

$$\tan \phi = \frac{5}{2.5} = 2$$

i.e. the p.f. angle at which maximum regulation occurs is $\phi = \tan^{-1} 2 = 63.4^\circ$ and hence p.f. $\cos 63.4 = 0.447 \approx 0.45$ **Ans.**

and the regulation is

$$\begin{aligned} & 2.5 \cos 63.4 + 5 \sin 63.4 \\ &= 1.125 + 5 \times 0.894 \\ &= 1.125 + 4.47 \\ &= 5.6\% \quad \mathbf{Ans.} \end{aligned}$$

Example 5.21. Determine (i) the full load efficiency at unity p.f. (ii) the voltage at the secondary terminals when supplying full load secondary current at p.f. (a) unity (b) 0.8 lagging (c) 0.8 lead for the 4 KVA 200/400 V, 50 Hz single phase transformer of which the following are the test figures.

O.C. Test 200 V, 0.8 A, 70 W

S.C. Test 17.5 V, 9 A, 50 W

Solution. (a) From the O.C. we have iron loss as 70 W

$$R_o = \frac{V^2}{P_i} = \frac{200 \times 200}{70} = 571.4 \Omega$$

$$\begin{aligned} I_w &= \frac{200}{571.4} = 0.35 \text{ A, Hence } I_\mu = \sqrt{0.8^2 - 0.35^2} \\ &= 0.72 \text{ Amp.} \end{aligned}$$

$$X_o = \frac{200}{0.72} = 1278 \Omega$$

$$R_{2e\phi} = \frac{50}{9^2} = 0.617 \Omega ; Z_{2e\phi} = \frac{17.5}{9} = 1.94 \Omega$$

$$\text{Hence } X_{2e\phi} = \sqrt{1.94^2 - 0.617^2} = 1.84 \Omega$$

$$\text{Full load current is } \frac{4000}{400} = 10 \text{ A}$$

Hence copper loss at 10 A is $50 \times \left(\frac{10}{9}\right)^2 = 61.7$ watts

(i) % η at unit p.f. $\frac{4000 \times 100}{4000 + 70 + 61.7} = 96.8$

(ii) Taking secondary current as reference, the phasor diagram for unity p.f. load is

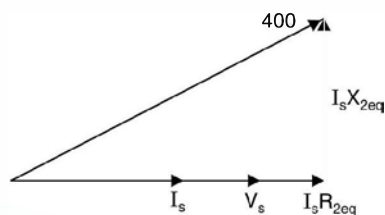

Fig. E5.21.1

$$400 = V_s + 10 \times 0.617 + j10 \times 1.84$$

$$= (V_s + 6.17) + j18.4$$

$$160000 = V_s^2 + 12.34V_s + 38 + 338.56$$

or

$$V_s^2 + 12.34V_s - 159623 = 0$$

or

$$V_s = \frac{-12.34 \pm \sqrt{152 + 638492}}{2} = \frac{-12.34 + 799}{2}$$

$$= 393.4 \text{ Volts} \quad \text{Ans.}$$

(b) The phasor diagram for 0.8 p.f. lag

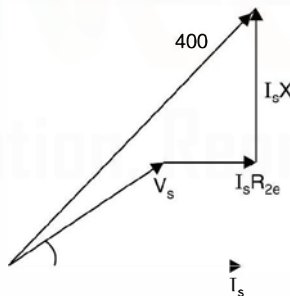

Fig. E5.21.2

$$400 = (V_s \cos \phi + I_s R_{2re}) + j(V_s \sin \phi + I_s X_{2e})$$

$$= (0.8V_s + 6.17) + j(0.6V_s + 8.4)$$

$$400^2 = V_s^2 + 2V_s I_s (R_{2e} \cos \phi + X_{2e} \sin \phi) + I_s^2 (R_{2e}^2 + X_{2e}^2)$$

$$= V_s^2 + 20V_s (0.617 \times 0.8 + 1.84 \times 0.6) + 100(0.617^2 + 1.84^2)$$

$$= V_s^2 + 31.95V_s + 376$$

or

$$V_s^2 + 31.95V_s - 159624 = 0$$

or

$$V_s = \frac{-31.9 \pm \sqrt{1021 + 638496}}{2} = \frac{-31.9 \pm 799.7}{2}$$

or

$$V_s = 383.89 \approx 383.9V \quad \text{Ans.}$$

(c) The phasor diagram for 0.8 p.f. lead

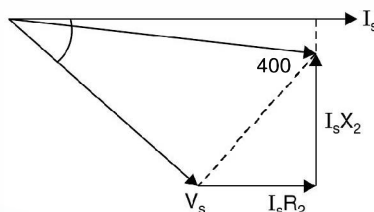

Fig. E5.21.3

$$\begin{aligned} 400^2 &= (V_s \cos \phi + I_s R_2) + j(V_s \sin \phi - I_s X_2) \\ &= (0.8V_s + 6.17) + j(0.6V_s - 18.4) \\ &= V_s^2 + 2 \times 6.17 \times 0.8V_s + 6.17^2 - 2 \times 0.6 \times 18.4V_s + 18.4^2 \\ &= V_s^2 + 9.872V_s - 22.08V_s + 376 \\ 0 &= V_s^2 - 12.2V_s - 159624 \end{aligned}$$

or

$$\begin{aligned} V_s &= \frac{+12.2 \pm \sqrt{149 + 638496}}{2} = \frac{+12.2 \pm 799.1}{2} \\ &= 405.65V \quad \text{Ans.} \end{aligned}$$

PROBLEMS

- 5.1. Calculate in terms of the primary the equivalent resistance and the leakage reactance of a transformer which gave the following data on test with the secondary terminals short circuited ; Applied voltage 60 V, current 100 A, power input 1.2 kW. Ans. 0.12 Ω , 0.59 Ω .
- 5.2. The required no-load ratio in a 1-phase 50 Hz core type transformer is 6000/250 V. Find the no. of turns in each winding if the flux is to be about 0.06 wbs. Ans. 480, 20.
- 5.3. A 50 Hz 1-phase transformer has a turn-ratio of 6. The resistances are 0.90 ohm and 0.03 ohm and the reactances 5 ohm and 0.13 Ω for high voltage and low voltage respectively. Determine (a) the voltage to be applied to the high voltage side to obtain full load current of 200 A in the low voltage winding on short circuit (b) the p.f. on short circuit. Ans. (a) 330 V (b) 0.2.
- 5.4. The high and low voltage windings of a 6600/250 V 50 Hz 1-phase transformer have resistances of 0.21 ohm and 2.72×10^{-4} ohm and reactances of 1.0 ohm and 1.3×10^{-3} ohm respectively. Determine the current and power input when the high voltage winding is connected to a 400 V 50 Hz supply, the low voltage winding being short-circuited. Ans. 206 A ; 17 kW.
- 5.5. The equivalent circuit shown refers to a 200/400 V 1-phase 50 Hz 4 KVA transformer, the values given being reduced to the low voltage side. For a high voltage current of 10 A at a lagging p.f. of 0.8, calculate

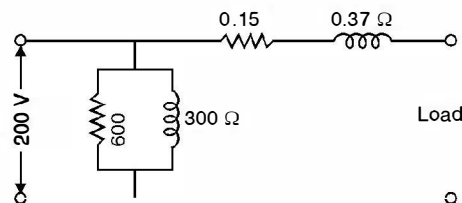
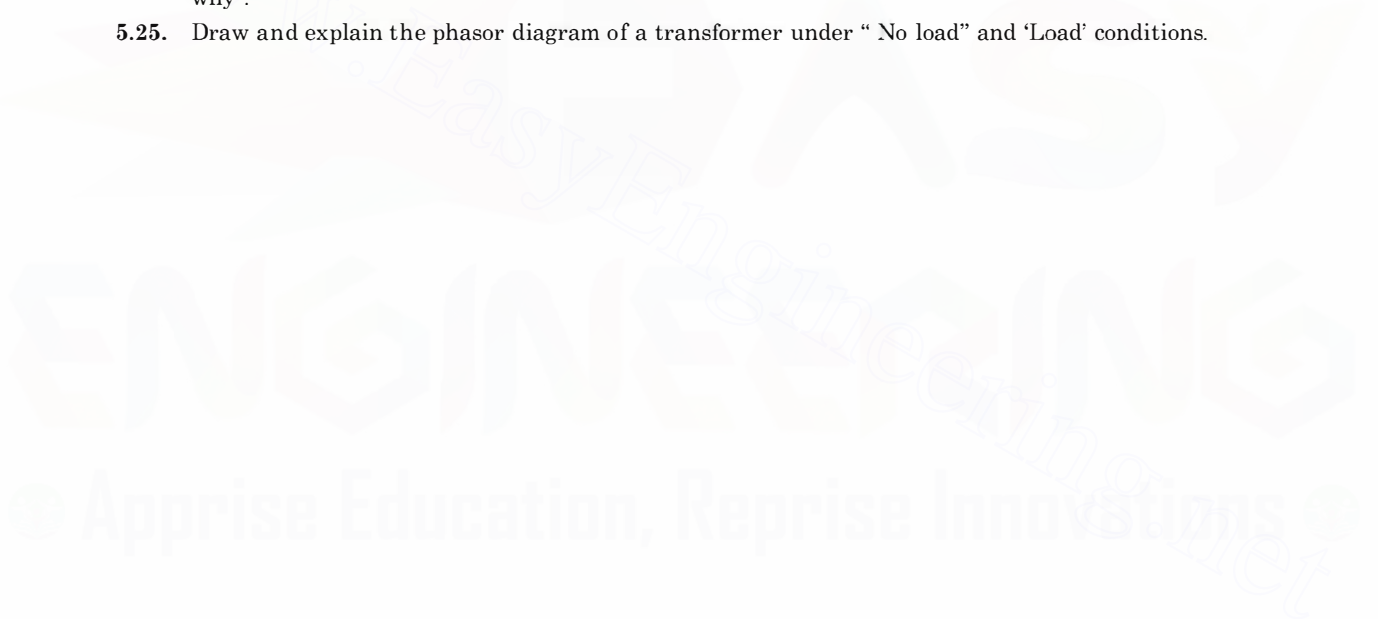

Fig. P5.5

- (a) The low voltage input current
 (b) The efficiency
 (c) The voltage at the terminals of the high voltage side. **Ans.** (a) 20.65 A (b) 96.08% (c) 386 V.
- 5.6. The efficiency, at unity p.f. of a 6600/384 V 200 KVA, 1-phase transformer is 98% both at full load and half load. The p.f. on no load is 0.2 and the full load regulation at a p.f. 0.8 lag is 4%. Determine the equivalent parameter values referred to the LT side.
Ans. $R_0 = 108 \Omega$ $X_0 = 22.1 \Omega$ $R = 0.01 \Omega$ $X = 0.036 \Omega$.
- 5.7. A 100 KVA 6600/330 V, 50 Hz single phase transformer took 10 A and 436 watt at 100 V in a short circuit test ; the figures referring to the HT side. Determine the voltage to be applied to the HT side on full load at p.f. 0.8 lag when the secondary terminal voltage is 330 V. **Ans.** 6734 V.
- 5.8. Determine the efficiency of a 150 KVA transformer at 25%, 33% and 100% full load (a) at unity p.f. (b) at 0.8 p.f. lag if the copper loss is 1600 W at full load and the iron loss is 1400 W.
Ans. (a) 96.15, 96.94, 98.04% (b) 95.23, 96.21, 97.56%.
- 5.9. The efficiency of a 400 KVA 1-phase transformer is 98.77% when delivering full load at 0.8 pf and 99.13% at half full load and unity p.f. Calculate (a) the iron loss (b) the full load copper loss.
Ans. (a) 1 kW (b) 3 kW.
- 5.10. A 50 KVA 2000/200 V transformer has impedance drop of 10% and resistance drop of 4% (a) Find regulation at full load 0.8 lag (b) Find p.f. for which the regulation is zero. **Ans.** 8.7% 0.917 lead.
- 5.11. A 230/2300 volt single phase transformer is excited by 230 V ac supply. The equivalent resistance and reactance when referred to primary winding are 0.2 and 0.8 ohm respectively. R_0 and X_0 are 500 Ω and 200 ohm respectively. The load impedance is $400 + j 600$ ohms. Determine (a) primary current (b) secondary terminal voltage (c) power factor at primary terminals.
Ans. 30 $\angle -58.7^\circ$, 2075.4 V, 0.52 lag.
- 5.12. A 100 KVA distribution transformer is supplying the following loads
 80 kW at 0.8 p.f. for 8 hrs.
 40 kW at unity p.f. for 6 hrs.
 No load for the remaining 10 hrs.
 Determine all day efficiency if full load copper losses are 2 kW and iron loss 1 kW. **Ans.** 95.5%.
- 5.13. A single phase auto-transformer is to transmit a power of W kW from the primary network at V_1 volts to the secondary at V_2 volts. Determine the rating of each section of the winding and compare it with the rating of a two winding transformer assuming an efficiency of η in both the cases. Evaluate for $V_2 = 0.9 V_1$ W = 100 kW and $\eta = 0.97$. Ignore magnetising current.
Ans. Primary = 103.2/10.32 ; Secondary = 100/7.22
- 5.14. What is an auto-transformer ? Discuss its merits and demerits over a two-winding transformer.
- 5.15. Show that an auto transformer is more useful (copper saving) as compared to a two-winding transformer for transformation ratio close to unity.

- 5.16. Explain how the change in load current in the secondary affects the current on the primary side.
- 5.17. Explain what you mean by equivalent resistance referred to the primary side or secondary side.
- 5.18. Explain with neat diagram what you mean by polarity test of a transformer and also discuss how 1-phase transformers are connected in (a) parallel (b) star or (c) delta connections.
- 5.19. Explain with neat diagram OC and SC tests. "OC test normally is conducted on the low voltage side whereas the SC test is conducted on the high voltage side".
Give reasons what informations you gather from these two tests.
- 5.20. Explain with a neat diagram Sumpner test and discuss its advantage over direct loading of transformer.
- 5.21. Starting from first principle draw the approximate equivalent circuit of a transformer.
- 5.22. Define voltage regulation of a transformer and develop an expression for calculating the regulation.
- 5.23. Explain various losses in a transformer and derive the condition for maximum efficiency of a transformer.
- 5.24. What is "All-day efficiency" ? For which type of transformers this efficiency is important and why ?
- 5.25. Draw and explain the phasor diagram of a transformer under " No load" and 'Load' conditions.



CHAPTER

6

DC Machines

6.1 INTRODUCTION

The first electromagnetic machines to be developed were dc machines. The first central power station developed by Thomas A. Edison to serve a part of New York City had dc generators in 1882 which operated at 110 V d.c. The use of transformers for transmitting power over longer distances and at higher voltages justified the use of a.c. especially where the electric energy was to be harnessed from water power which usually is available far from the load centres. When alternating current supplemented dc as the mode for the generation and transmission of electrical energy, induction and synchronous machines supplemented dc machines as motors and generators to a large extent. Still today dc machines account for about 40 per cent of the dollar volume in electrical-machine manufacturing and sales. This is because

- (i) most highway vehicles use lead-acid batteries for electrical energy storage. The starter motors, windshield wiper motors, fan motors and motors to drive other accessories in vehicles must be dc motors. Literally millions of dc motors are manufactured every year for such purposes.
- (ii) dc motors have very accurate speed/torque characteristics as compared to other drives. DC motors are, hence, nearly the universal choice for driving power shovels, steel and aluminium rolling mills, electric elevators, railroad locomotives and large earth moving equipment.

6.2 CONSTRUCTION

A d.c. machine consists of two parts : the stator *i.e.* the stationary part and the rotor *i.e.* the rotating part. Fig. 6.1 shows a sectional view of a 4-pole dc machine. The field poles are located on the stator and project inward from the inside surface of the iron cylinder that forms the stator yoke. The yoke serves as a return path for the pole flux. Each iron pole consists of a narrower part, called the pole core around which is placed the exciting winding called field winding or coil. This coil may consist of two or more separate windings to provide for controlling the strength of the field flux. A pole shoe, usually laminated, distributes the pole flux over the rotor surface. The surface of the pole shoe opposite the rotor is called the pole face. The space between the pole face and the rotor surface is called the air gap. As the teeth of the rotor core sweep past the pole faces, localised variations in the flux density within the pole shoe are produced. These flux density

variations produce hysteresis and eddy current losses. Laminating the pole shoes greatly reduces the eddy current loss in the iron of the pole shoes.

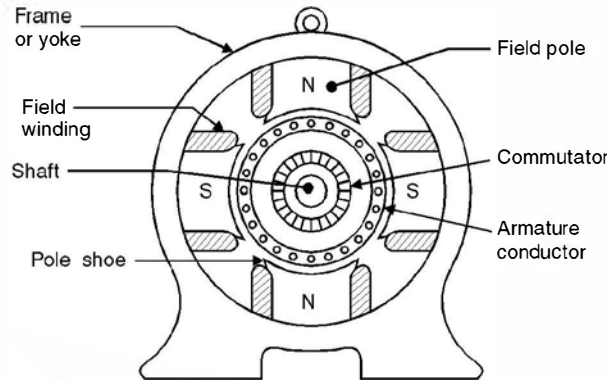

Fig. 6.1. Sectional view of a 4-pole dc machine.

Fig. 6.2 shows a longitudinal view of armature *i.e.* rotor along with two coils of the winding. The armature winding is composed of coils embedded in slots in the rotor. The armature has a cylindrical steel core consisting of a stack of slotted laminations. The slots in the laminations are aligned to form axial slots in the outside surface of the core, in which the coil sides of the armature winding are placed. In small machines, the slots are sometimes skewed. Skewing makes winding a little more difficult, but it results in quieter operation and a slight reduction in losses. The laminated iron between the slots forms the teeth of the core. The armature coils are often held in place by wood or fibre 'wedges' driven into the slots from one end of the core stack.

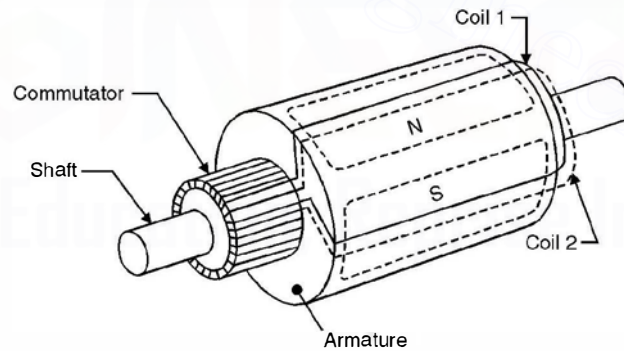

Fig. 6.2. Longitudinal view of armature and commutator.

The leads from the armature coils are connected to the commutator. The commutator consists of radial copper segments separated from each other by insulating material, usually mica. Current is conducted to the armature coils by carbon brushes that are held against the cylindrical surface of the commutator by the force of springs. The brushes should have proper conductivity and sliding-friction characteristics for a given motor. Brushes should be fitted to the surface of the commutator. They are held in brush holders and must be free to slide radially in these holders to maintain contact with the commutator as they wear away. Current is carried into the brush by a 'pigtail' or "brush shunt". This is a very flexible wire embedded in the brush

material and connected to the brush holder. Brushes are normally placed along the magnetic neutral axis. Brushes must be inspected regularly and replaced as necessary, as they are worn away. The emf induced in the conductors of the dc machine is an alternating emf. The commutator helps in converting this alternating emf into direct current emf. This is, therefore, also known as mechanical converter.

Mainly there are two types of windings on the armature, the lap and the wave winding. The lap winding has the number of parallel paths equal to the number of poles or no. of brushes. The total induced emf is the emf induced in one path and the current delivered to the external circuit equals the current in each armature coil multiplied by the no. of parallel paths.

In contrast the wave winding has only two parallel paths irrespective of the no. of poles and hence wave winding is suitable for large voltage small currents whereas lap winding for small voltage large currents.

6.3 EMF EQUATIONS

A dc machine may be a dc generator or a dc motor. The dc generator converts mechanical energy into the electrical energy whereas a dc motor converts electrical energy into mechanical energy. A dc generator works on the principle that the motion of a conductor (mechanical energy) through a magnetic field causes an emf to be induced in the conductor.

However when a current carrying conductor is brought in a magnetic field and the conductor cuts the flux lines (not parallel to flux lines), a force acts on the conductor and thus torque is developed and the electric energy is converted into mechanical energy.

The pole faces are so designed that the magnetic flux lines cut the conductors in the armature slots radially and hence when the armature is rotated with the help of a prime mover the flux lines cut the conductor and an emf is induced in the conductor which is given by

$$e = Blv \quad (6.1)$$

where e is the voltage induced in one conductor whose length is l metres and is moving with velocity v metres/sec and the conductor is moving in a magnetic field of flux density B Wb/m². If Z is the total number of conductors and A the number of parallel paths, the no. of conductors in series is Z/A . Therefore emf E generated is

$$E = B.lv.\frac{Z}{A} \quad \dots(6.2)$$

Let ϕ be the flux per pole, P the number of poles, the total flux in the air gap is $P\phi$. This gap is in the form of a cylinder with length equal to the armature conductor length and r the radius of the air gap. Since the flux in the air gap is radial, the normal cross-section of the flux is the surface of the cylinder and equals $2\pi rl$

Hence flux density B

$$B = \frac{\phi P}{2\pi rl} \quad \dots(6.3)$$

If N is the speed of rotation of the armature in rpm, the linear velocity is

$$v = \frac{N2\pi r}{60} \quad \dots(6.4)$$

Substituting the values of B and v in equation (6.2) we have

$$\begin{aligned} E &= \frac{P\phi}{2\pi r l} \cdot l \cdot \frac{N2\pi r}{60} \cdot \frac{Z}{A} \\ &= \frac{P\phi NZ}{60A} \quad \dots(6.5) \\ &= K\phi N \end{aligned}$$

where $K = \frac{ZP}{60A}$ and depends upon the design of the machine and is constant for a particular machine.

When current is flowing out of the + brushes, the torque opposes the rotations. The machine is acting as a generator and the voltage generated is given by equation (6.4) and is a source voltage for the current. However, when current is flowing into the + brushes, the torque is in the direction of rotation and the machine is acting as a motor. The generated voltage is again given by equation (6.4) but this is known as counter voltage *i.e.* voltage acting in opposition to supply voltage.

The polarity of voltage induced in the generation mode of operation of dc machine is given by Fleming's right hand rule and is stated as follows :

Hold the thumb, forefinger and the central finger of the right hand at right-angles to each other. If the thumb points to the direction of motion and forefinger to the direction of field, the central finger will point in the direction of induced emf *i.e.* the central finger will point to the positive terminal of emf or will indicate the direction of current flow if the ends of the conductor are connected to the external circuit (load).

Similarly the direction of force on a current carrying conductor in the motoring mode of operation of a dc machine, when conductor is situated in a magnetic field is given by Fleming's left-hand rule and is stated as follows :

Hold the thumb, the forefinger and the central finger at right angle to each other of the left hand. If the forefinger points in the direction of magnetic field and the central finger to the direction of current, the thumb will point to the direction of force or motion.

In motoring action when a conductor of length l carrying a current I amperes is brought in a magnetic field of strength B Wb/m², it experiences a force BIl and thus a torque is developed which rotates the armature. As a result of rotation (motion) of armature conductor in a magnetic field due to stator poles voltage in the rotor conductor is induced which is known as a counter emf or back emf which opposes the applied voltage (supply voltage). It is through the mechanism of back emf that a motor adjusts its electrical input to meet an increase or decrease in mechanical load on shaft. It is to be noted that the commutator acts as a mechanical inverter for motoring action and hence the current in armature conductors is alternating and not direct current. Interaction of the two fluxes the stator magnetic field and the armature conductor current magnetic field which are displaced in time and space develop the torque which is directly proportional to the product of the magnitude of the two fluxes.

6.3.1 Armature Reaction

When a current flows through a conductor magnetic field is set-up around the surface of the conductor. If this conductor is normal to the paper and current is entering the paper, according to

Right Hand Screw rule the flux lines encircle the conductor clockwise. However, if the current is coming out of the paper, the flux lines encircle the conductor anticlockwise. So when current flows through the armature conductors it gives rise to magnetic flux. The magnetic field produced due to current carrying armature conductor distorts the magnetic field produced by the field poles. This effect is known as armature reaction.

Fig. 6.3 shows a two pole dc generator. Suppose the brushes are placed along the geometric neutral plane as shown in Fig. 6.3. The direction of current is given by Fleming's right hand rule and accordingly it is shown in the Fig. 6.3 indicating that the current is going into the paper under the north pole and hence the flux lines are in clockwise direction. However, under the south pole the currents are coming out of the paper and the net flux lines are anticlockwise. The resultant armature flux lies along the geometric neutral plane (GNP) and is indicated by OA. The main field flux is of course from the north pole to south pole and is indicated by OD. The phasor sum of OA and OD gives the resultant flux OE.

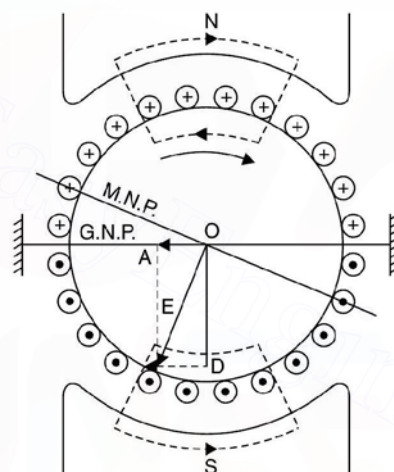

Fig. 6.3. Armature reaction in a dc generator.

When field due to armatures conductors is not there, the magnetic neutral plane coincides with the geometric neutral plane. However, if the flux due to armature conductor is present, the magnetic neutral plane will be perpendicular to this resultant field OE and is thus shifted from the GNP in the direction of rotation of the armature. The higher the loading of the generator higher is the armature flux and greater is the shift of the magnetic neutral plane. For clear understanding of the effect of armature current on the main magnetic field refer to Fig. 6.4. It is clear from the Fig. 6.4 that the main flux tends to increase at the trailing pole (North pole) tips and decreases at the leading pole tips. This is known as cross magnetising effect of armature reaction. The field at the trailing pole tips is strengthened and that under the leading pole tips it is weakened. If the armature teeth were not saturated, the total flux would remain constant. However, due to saturation of armature teeth, it is possible that strengthening of trailing pole tips may be smaller than the weakening of leading pole tips. Therefore, a small amount of demagnetisation may also occur.

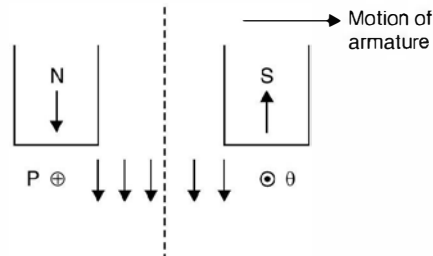

Fig. 6.4. Effect of armature reaction in generator, PQ is a coil.

In order to improve the process of commutation. It is desirable to place the brushes along the magnetic neutral plane as shown in Fig. 6.5.

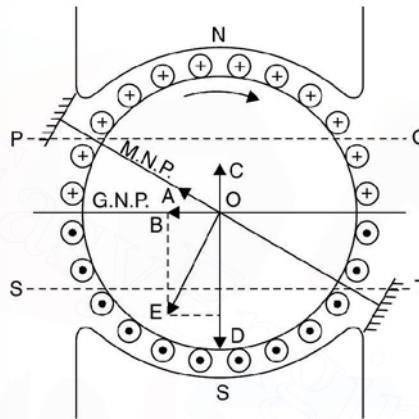

Fig. 6.5. Demagnetising and cross magnetising effects of armature reactions.

From Fig. 6.5 it is seen that the armature mmf OA can be decomposed into two component OB and OC . The component OB is the cross magnetising component whereas OC is the demagnetising component as it is in opposition to the main flux OD . The armature ampere turns between the horizontals PQ and ST are the demagnetising ampere turns and the remaining ampere turns *i.e.* those above PQ and below ST are cross magnetising ampere turns.

If armature has A parallel paths, the armature current per parallel path is I_a/A where I_a is the total armature current. Let Z be the total number of conductors and P the number of poles,

$$\text{The armature ampere conductors per pole} = \frac{I_a}{A} \cdot \frac{Z}{P}$$

$$\text{Armature ampere turns per pole} = \frac{I_a}{2A} \cdot \frac{Z}{P}$$

Suppose the brushes are shifted from the geometric neutral plane to magnetic neutral plane by an angle θ° electrical angle. Then in every inter polar region the conductors lying in a region of $2\theta^\circ$ contribute to demagnetising effect whereas the remaining conductor's *i.e.* those lying in an angle of $180 - 2\theta$ contribute to cross magnetising effect.

$$\text{Demagnetising AT/pole} = \frac{2\theta}{180} \cdot \frac{I_a Z}{2AP} = \frac{I_a Z}{AP} \cdot \frac{\theta}{180}$$

$$\text{Crossing magnetising AT/pole} = \frac{180 - 2\theta}{180} \cdot \frac{I_a Z}{2AP}$$

From the above analysis it is clear that if $\theta = 0^\circ$ *i.e.* the brushes are placed along GNP, demagnetising ampere turns are zero and hence the entire ampere turns are cross magnetising *i.e.* they assist the main flux due to poles. It is to be noted that in case of d.c. motor the trailing tips of the poles are weakened whereas those of leading pole tips are strengthened.

6.3.2 Commutation

The carbon brush makes contact with the commutator segment during the process of commutation. In this process the current in a coil has to change from $+I$ to $-I$. The time taken for this change is very short and is known as commutation period.

Fig. 6.6 (a) shows the beginning of process of commutation in coil C. The current collected by the brush is I each from coils B and C *i.e.* a total of $2I$ amperes coil C is carrying current from right to left.

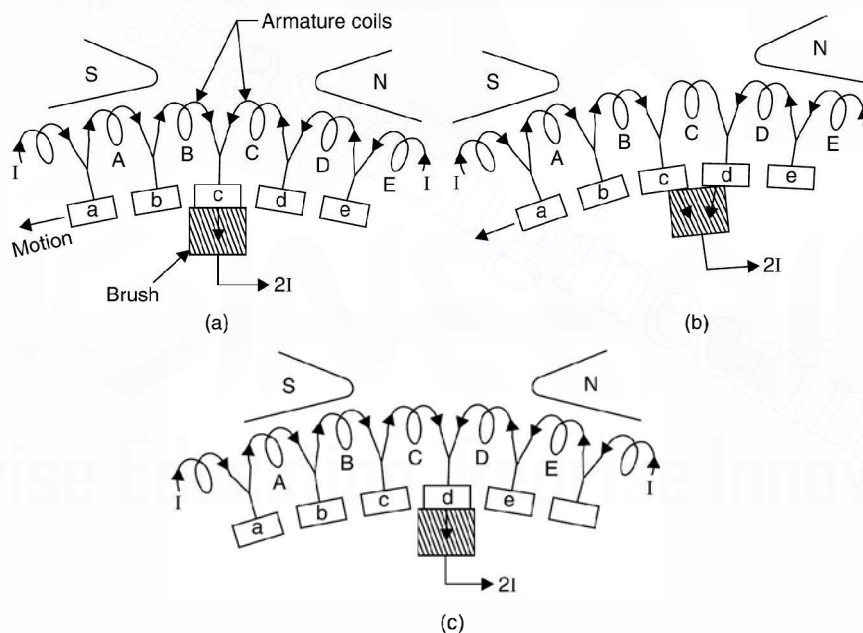

Fig. 6.6. Commutation.

In Fig. 6.6 (b) the brush is spanning the commutator segments *c* and *d*. The current to the brush is contributed equally by coils B and D. This current reaches the brush without passing through coil C, which is not carrying any current at this instant. Fig. 6.6 (c) shows the operation at the next instant. Coil C is now moving under an S pole and the current is in the direction from left to right. Thus the current in coil C must change from $+I$ to $-I$ during this period of short circuit which is about 2 m sec. If the current does not reach the full value $-I$ at the end of this

period of short circuit, the difference of current would go from commutator to the brush in the form of a spark. Such sparking causes heating, pitting and roughening of the commutator surface.

Suppose L is the inductance of the coil and the current changes from $+I$ to $-I$ in a time T_c (commutation time) a self induced emf $L \frac{di}{dt}$ known as reactance voltage appears and is given as reactance voltage $\frac{2LI}{T_c}$ volts. The direction of this induced emf is such that it opposes the change in current.

Armature reaction and reactance voltage adversely affect the commutation process. Following are the methods to overcome commutation problem.

- | | |
|-----------------------------------|----------------------------|
| (i) Brush shifting | (ii) Inter poles |
| (iii) High resistance brushes and | (iv) Compensating winding. |

The former two methods minimise the commutation problem due to reactance voltage whereas the latter two to armature reaction.

(i) **Brush shifting.** In this method the brushes are shifted by an angle slightly more than the magnetic neutral axis (due to armature reaction) so that the brushes lie in the zone of next pole. Because of this an emf is induced in the coil undergoing commutation due to the influence of the next pole and this emf cancels the reactance voltage. However, this method poses certain practical difficulties. The magnetic neutral axis itself goes on changing as the loading on the machine changes as a result the armature reaction changes. Every loading requires different brush shifting and hence it is not a practical method.

(ii) **Inter poles.** Fig. 6.7 shows inter pole in a dc generator. These are also known as commutating poles. These are small auxiliary poles situated between the main poles. For a generator an inter pole should have polarity which is the same as that of the next main pole. These commutating poles induce an emf in the coil undergoing commutation which opposes and hence cancels the reactance voltage. Since the reactance voltage is proportional to the armature current, the inter poles are connected in series with the armature circuit. It is to be noted that the commutating field should be of proper magnitude. It should neither be too strong nor too weak. If it is too strong it will over compensate the reactance voltage and the arc will be in the reverse direction and this is known as over commutation.

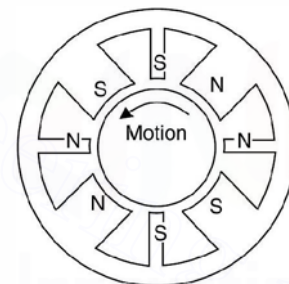

Fig. 6.7. Interpoles in a dc generator.

(iii) **High resistance method.** The use of brushes having high contact resistance improves the commutation. In Fig. 6.6 the brush is making contact with commutator segments c and d . When the current from coil B reaches segment c , it flows partly through coil c and segment d and partly direct to the brush. If the contact resistance is high, more and more current tends to flow through the first path *i.e.* via coil C. This is due to the fact that the area of segment c in contact with brush is decreasing and the area of segment d in contact with brush is increasing. This process thus improves commutation. The use of carbon and graphite for the brush material provide high contact resistance and is used in all dc machines.

(iv) **Compensating winding.** In heavy duty dc machines the change in armature current may be large which would cause large and sudden change in flux and induce a high emf in

the armature coil. This emf may cause severe arc over the commutator surface. Compensating winding is designed to cancel armature reaction, neutral shift and flux weakening. This winding is placed in slots cut in pole faces, parallel to the rotor conductors. It is connected in series with armature circuit in such a way that the ampere turns of compensating winding are equal and opposite to those of armature conductors which are opposite to pole face. Thus the compensating winding cancels the effect of armature reaction.

It is, therefore, important to note that the ampere conductors of the compensating winding should equal to the active ampere conductors of the armature per pole

$$\text{or} \quad \frac{I_a}{A} Z_a = I_a Z_p \quad \text{or} \quad Z_p = \frac{Z_a}{A}$$

When Z_p is the number of conductors of compensating winding in each pole face, Z_a is the number of active armature conductors per pole and A of course is the number of parallel paths of the armature winding.

The use of compensating winding involves additional cost and copper losses of the machine. It is, therefore, used (i) if the motor is likely to be subjected to very heavy duty cycle as in rolling mills (ii) if the generator has to supply high current at a low voltage.

6.4 CLASSIFICATION OF DC MACHINES

It is to be noted that there is no difference in the construction of dc motor or generator. A dc machine which is being used as a dc generator can also be used as a dc motor and *vice versa*. Hence dc machines in general are classified based on the connection of the field coil and the armature winding terminals. Refer to Fig. 6.8 for different connections.

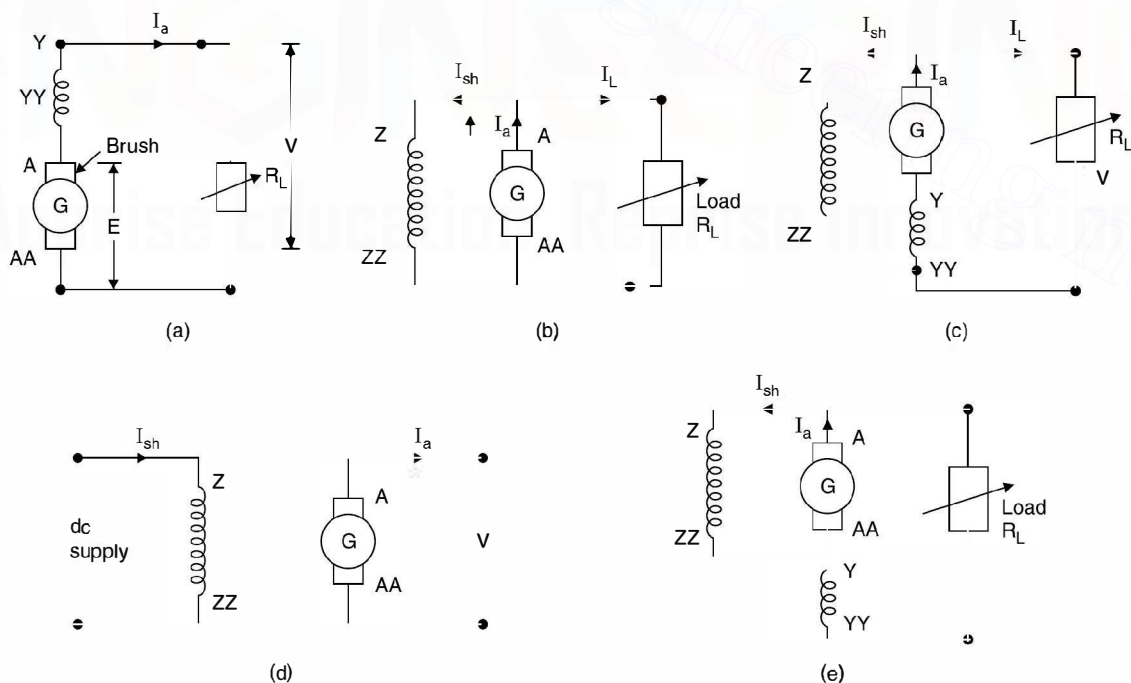

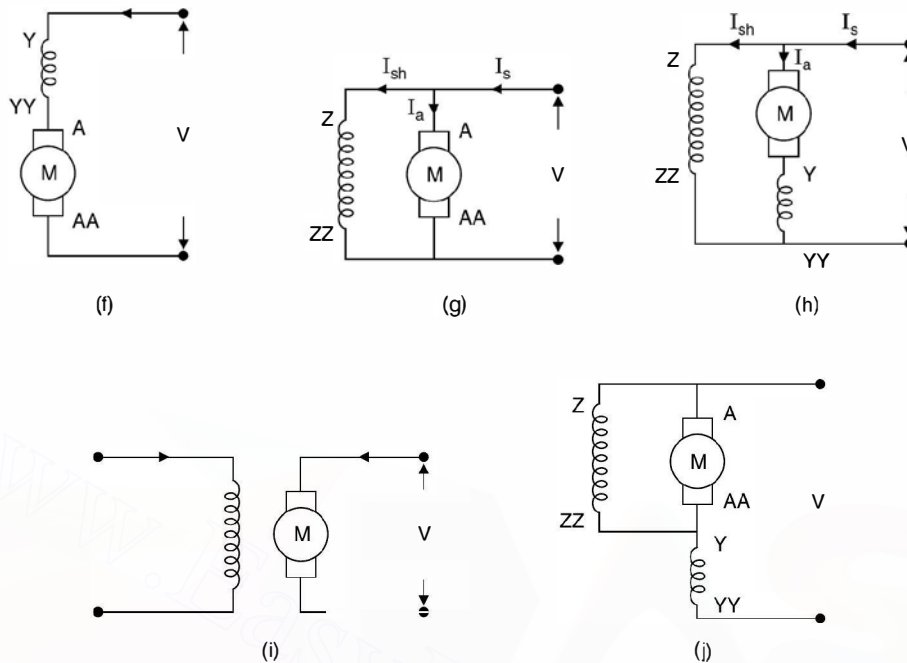

Fig. 6.8. (a) to (e) dc generators, (f) to (j) dc motors.

In Fig. 6.8 A, AA stand for armature terminals

Z, Z Z for shunt field terminals

Y, Y Y for series field terminals

In Fig. 6.8 (a) since the field winding is connected in series with the armature, it is known as dc series generator. Similarly in Fig. 6.8 (f) the machine is known as dc series motor. In Fig. 6.8 (b) and (g) the field winding is connected in shunt with the armature terminals, these machines are called d.c. shunt generator and motor respectively.

In Fig. 6.8 (c) and (f) we have both the field windings series as well as shunt winding. If the two windings are so connected that their fluxes add, the connection is known as cumulatively compounded dc generator and motors respectively. However, if the two fluxes oppose each other, the connection is known as differentially compounded dc generator and motors respectively. Also if ZZ is connected to YY of the series field it is known as long shunt connection whereas if ZZ is connected to Y as shown in Fig. 6.8 (e) and j it is known as short shunt connection. In Fig. 6.8 (d) and (i) the field winding is not connected to the armature terminals and hence these are known as separately excited dc generator and motor respectively.

The series field winding has few turns and since it is connected in series with the armature and the load in case of generator, the current through the field winding is large and hence the field winding has thicker conductor. The resistance R_{se} is in terms of fraction of an ohm. The armature resistance R_a is also in terms of fraction of an ohm. However, the shunt field winding has large number of turns and the conductor cross-section is very small. It's resistance is in terms of

hundreds of ohms. Let E be the induced emf in case of generators and E_b the back emf for a dc motor, I_a armature current, I_L load current, I_{sh} the shunt field current. Following relations can be obtained for the generators and motors after referring to the circuit diagram shown in Fig. 6.8. Fig. 6.8 (a) is for series generator

$$E = V + I_a(R_{se} + R_a) \quad \dots(6.6)$$

where V is the terminal voltage after load R_L is connected. In fact without connecting load in case of dc series generator no voltage can be induced as series field circuit is open. Fig. 6.8 (b) is for shunt generator

$$I_a = I_{sh} + I_L \quad \dots(6.7)$$

and

$$E = V + I_a R_a \quad \dots(6.8)$$

Similar relations can be written for other generator circuits. For series motor

$$V = E_b + I_a (R_a + R_{se}) \quad \dots(6.9)$$

For shunt motor

$$I_s = I_a + I_{sh} \quad \dots(6.10)$$

and

$$V = E_b + I_a R_a \quad \dots(6.11)$$

Replacing the generator by its emf and internal resistance (armature resistance) and motor by its back emf and internal resistance we have the equivalent circuits for the series, shunt generators and motor as shown in Fig. 6.9.

Series, shunt and compound generators are self-excited dc generators *i.e.* they do not require any external source for excitation. However, as the name suggests separately excited dc generator requires an external dc source to excite its field winding.

Before we study conditions for self-excitation we first obtain magnetisation characteristics of these machines.

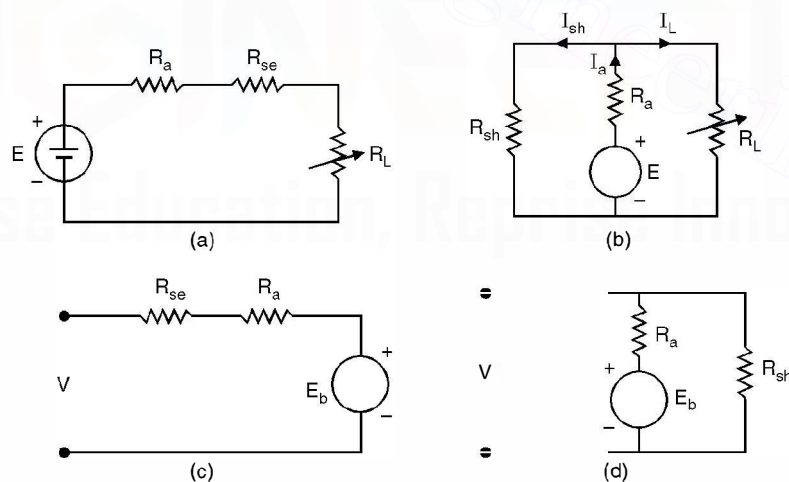

Fig. 6.9. (a) and (b) generator (c) and (d) motor.

6.5 MAGNETISATION CHARACTERISTICS

This characteristic is also known as open circuit characteristic *i.e.* when the machine is not loaded. It gives relation between the variation of generated voltage or no load voltage when the field current is varied and the machine is run at constant speed.

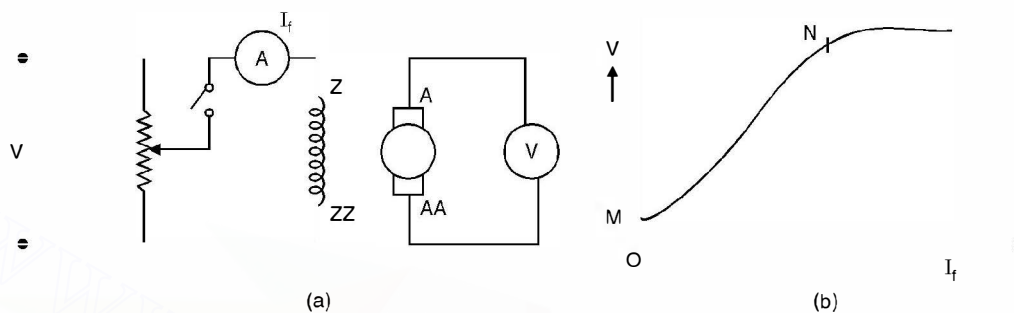

Fig. 6.10. Magnetisation characteristic of dc generator : (a) Circuit (b) Characteristic.

Fig. 6.10 (a) shows the circuit diagram and (b) shows the magnetisation characteristic. In Fig. 6.10 (a) a switch is connected in the field circuit. The motor is started and run at rated speed and the switch in the field circuit is left open. We will see that even though no current is flowing through the field, still some voltage equal to OM in Fig. (b) appears across the armature terminals. This is due to the residual magnetism in the stator poles. As we increase the field current the voltage recorded increases almost linearly. However, at some value of I_f (corresponding to point N in Fig. 6.10 (b)) the magnetic circuit starts getting saturated and hence further increase in I_f does not increase the flux proportionately and the voltage almost gets flattened.

Since the generated voltage is proportional to the speed, magnetisation characteristic for any other speed can be obtained from the test curve at one speed.

We now mention the necessary conditions for voltage build-up due to self-excitation :

1. Residual magnetism must be present.
2. The connection of the field winding with respect to armature terminals should be such that the field current strengthens the residual magnetism.
3. The resistance of the field winding should be less than the critical resistance.
4. The speed of the machine should be higher than critical speed.
5. In a series generator, the load should be connected and load current should flow. The resistance of the load should be less than critical resistance and speed should be higher than critical speed.

Because of paucity of space we will be very brief here we draw the circuit diagram and the characteristics which can be obtained using the circuit diagram Fig. 6.11 (a) circuit for self-excitation of dc shunt generator and (b) suggests the process of build up of voltage starting from residual magnetism OM .

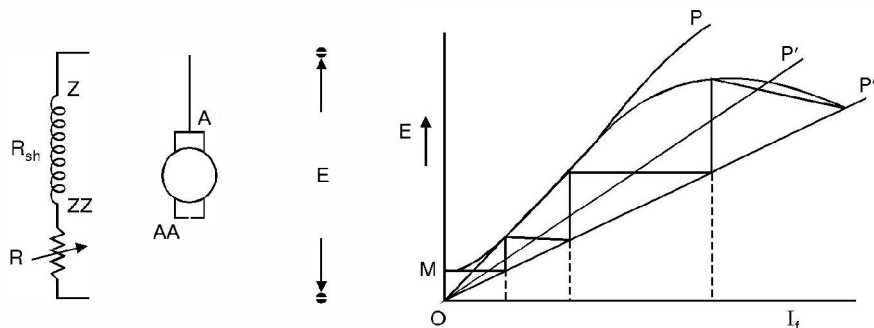

Fig. 6.11. Self-excitation (a) circuit (b) process of build-up of voltage.

Here OP' or OP'' represent the total resistance of the field circuit including R . The intersection of the magnetisation characteristic and the resistance line OP' or OP'' gives the final voltage induced.

It is seen that OP is the critical resistance line and the build-up of voltage is possible only if the field resistance is less than the critical resistance.

6.6 TERMINAL CHARACTERISTIC OF SHUNT GENERATOR

Fig. 6.12 (a) shows the circuit and Fig. 6.12 (b) the terminal characteristic of the dc shunt generator.

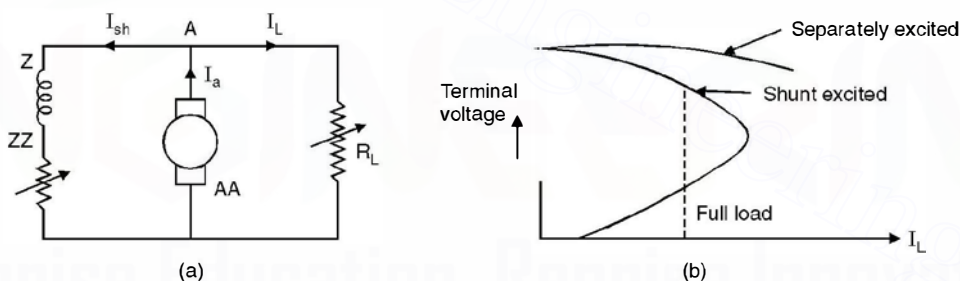

Fig. 6.12. (a) Connection diagram (b) Characteristic.

As the load on the shunt generator increases the armature drop $I_a R_a$ increases. This has a double effect. The terminal voltage V is given as

$$V = E - I_a R_a$$

Here E decreases due to increase in armature reaction and also because the field current decreases as V decreases. The voltage regulation is poor for most applications. However field rheostat may be adjusted to obtain the desired voltage at a given load. This is normally used as an exciter with synchronous machines.

6.6.1 Series Generator Characteristic

Fig. 6.13 (a) gives the connection diagram and 6.13 (b) the load characteristic.

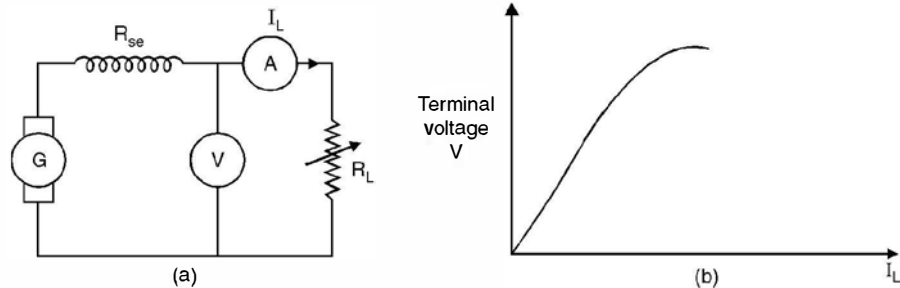

Fig. 6.13. (a) Connection diagram for series generator (b) characteristic.

It is seen that the terminal voltage of the generator increases as the load current increases. Since the terminal voltage increases with increase in load current, a series generator is suited for special applications. One such application is arc welding. As welding electrodes make contact with each other, before welding starts, a high current flows. As the welding electrodes separate, there is a steep rise in terminal voltage because armature reaction decreases due to slight decrease in current. The high terminal voltage ensures that arc will be maintained in air across the contacts so that welding will be accomplished.

Another application is as a series booster. It's connected in series with the line to compensate for the series voltage drop as the current in the line increases.

6.6.2 Load Characteristics of Compound Generator

Fig. 6.14 (a) shows the connection diagram and 6.14 (b) the characteristics.

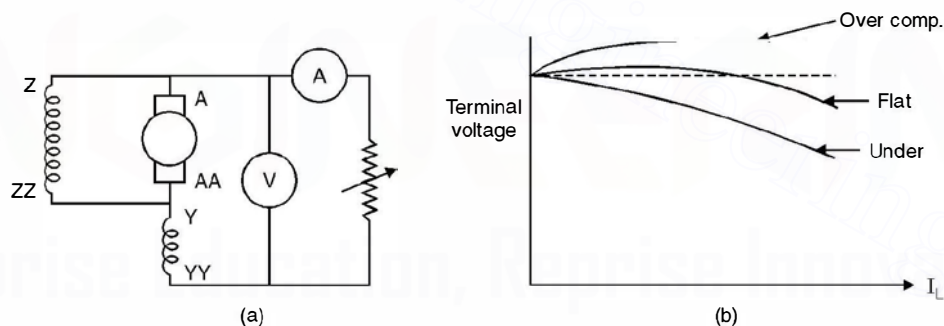

Fig. 6.14. (a) Connection diagram (b) Characteristics.

A cumulative compound generator is capable of much better voltage regulation. Since the load current flows through the series field, the pole mmf actually increases with load and so does the generated voltage E .

If the increase in E is not sufficient to overcome $I(R_a + R_{se})$ drops in the armature and series field resistances at full load, there will be positive voltage regulation and the machine is said to be undercompounded.

If the increase in E exactly compensates for the armature and series field $I(R_a + R_{se})$ drops at full load, the voltage regulation will be zero, and the generator is said to be flat compounded.

If the terminal voltage at full load is greater than that at no load (negative regulation) the generator is overcompounded.

An overcompounded generator is useful in mining applications, where the load may be at some distance from the generator. The rising voltage characteristic of the generator may be made to compensate for the $I(R_a + R_{sc})$ drop in the line, so that the voltage at the load may be virtually constant.

A differential compound generator is often used in power shovel drives.

Example 6.1. A 6-pole 2 circuit wave connected armature has 250 conductors and runs at 1200 rpm. The electromotive force generated on open circuit is 600 V. Determine the useful flux per pole.

Solution. Using equation (6.5) we have

$$E = \frac{\phi ZNP}{60A}$$

Here $Z = 250$, $N = 1200$ rpm, $E = 600$ V, $P = 6$, $A = 2$, $\phi = ?$

Substituting these values

$$600 = \frac{\phi \cdot 250 \cdot 1200 \cdot 6}{60 \times 2}$$

or

$$\phi = \frac{600 \times 60 \times 2}{250 \times 1200 \times 6} = 0.04 \text{ Wb} \quad \text{Ans.}$$

Example 6.2. An 8-pole lap connected armature has 960 conductors, a flux of 40 mWb per pole and a speed of 400 rpm. Determine the emf generated.

Solution. Using again equation (6.5) we have

$$E = \frac{\phi ZNP}{60A}$$

Here $\phi = 40$ mWb, $Z = 960$, $N = 400$ rpm, $P = 8$ and since it is lap connected $A = P = 8$.

Substituting these values we have

$$\begin{aligned} E &= \frac{40 \times 10^{-3} \times 960 \times 400 \times 8}{60 \times 8} \\ &= 256 \text{ volts} \quad \text{Ans.} \end{aligned}$$

Example 6.3. If in example 6.2 the armature were wave connected, at what speed it must be driven to generate 400 V.

Solution. Since the armature is wave connected the no. of parallel paths is 2 independent of no. of poles, hence

$$400 = \frac{40 \times 10^{-3} \times 960 \times N \times 8}{60 \times 2}$$

or

$$\begin{aligned} N &= \frac{400 \times 60 \times 2}{40 \times 10^{-3} \times 960 \times 8} = \frac{10^4 \times 60 \times 2}{960 \times 8} \\ &= 156 \text{ rpm} \end{aligned}$$

Example 6.4. A shunt machine connected to 250 V mains has an armature resistance (including brushes) of 0.12Ω and the resistances of the field circuit is 100Ω . Find the ratio of speed as a generator to the speed as a motor, the line current in each case being 80 A.

Solution. Shunt machine as a generator and as a motor is shown here.

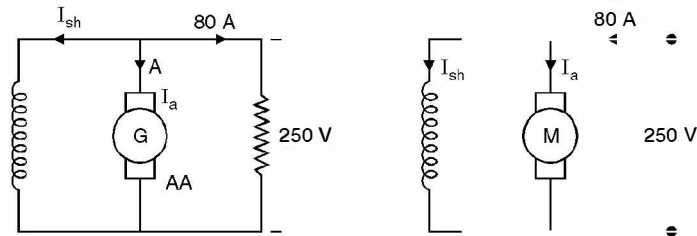

Fig. E 6.4

Since the terminal voltage is same and line current is same, the induced emf and back emf will be different.

For generator using equations (6.7) and (6.8)

$$I_a = I_L + I_{sh} = 80 + \frac{250}{100} = 82.5 \text{ A}$$

$$E = V + I_a R_a = 250 + 82.5 \times 0.12 = 259.9 \text{ volts}$$

For motor using equation (6.10) and (6.11)

$$I_a = I_L - I_{sh} = 80 - 2.5 = 77.5$$

$$E_b = V - I_a R_a = 250 - 77.5 \times 0.12 = 240.7 \text{ volts}$$

Since the emfs are directly proportional to speed if all other parameters are same, hence

$$\frac{\text{Generator speed}}{\text{Motor speed}} = \frac{259.9}{240.7} = 1.08 \quad \text{Ans.}$$

Example 6.5. A shunt generator has an induced voltage on open circuit of 127 V. When the machine is on load the terminal voltage is 120 V. Find the load current if the field circuit resistance be 15Ω and the armature resistance 0.02Ω . Ignore armature reaction.

Solution. Referring to Fig. E 6.5 and equations (6.7) and (6.8) we have

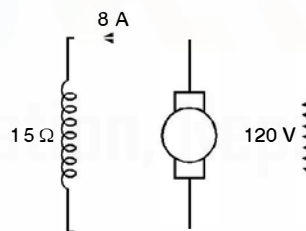

Fig. E 6.5

$$I_{sh} = \frac{120}{15} = 8 \text{ A}$$

$$I_a = I_L + I_{sh} = (I_L + 8)$$

$$E = V + I_a R_a$$

$$127 = 120 + (I_L + 8) \times 0.02$$

or

$$350 = I_L + 8 \quad \text{or} \quad I_L = 342 \text{ Amp} \quad \text{Ans.}$$

6.7 DC MOTORS

Assuming the losses to be negligibly small the power developed by the dc motor is given by

$$P = E_b I_a$$

Now

$$E_b = \frac{\phi ZNP}{60 A}$$

and

$$P = \frac{2\pi NT}{60} \text{ where } T \text{ is the torque in Nm}$$

Hence

$$\frac{2\pi NT}{60} = \frac{\phi ZNP}{60 A} \cdot I_a$$

or

$$T = \frac{\phi ZP}{2\pi A} \cdot I_a = K\phi I_a \quad \dots(6.12)$$

where

$$K = \frac{ZP}{2\pi A} \text{ constant for a dc machine}$$

Hence torque in a dc machine is proportional to the product of flux per pole in the air gap and the armature current

$$\text{Also we know that } E_b = \frac{\phi ZNP}{60 A} = K\phi N \quad \dots(6.13)$$

Assuming the armature drop to be negligibly small *i.e.* $V \simeq E_b$, the speed of a dc motor is inversely proportional to the flux per pole. We now study the torque-speed characteristics of d.c. series and shunt motors.

6.7.1 DC Shunt Motor

From equation (6.11)

$$V = E_b + I_a R_a$$

and from equation (6.13) we have

$$V = K\phi N + I_a R_a$$

or

$$N = \frac{V - I_a R_a}{K\phi} \quad \dots(6.14)$$

Now from equation (6.12) $T = K\phi I_a$,

substituting for I_a in equation (6.14) we have

$$\begin{aligned} N &= \frac{V}{K\phi} - \frac{R_a}{K\phi} \cdot \frac{T}{K\phi} \\ &= \frac{V}{K\phi} - \frac{R_a}{K^2 \phi^2} T \end{aligned} \quad \dots(6.15)$$

Under no load condition *i.e.* when load torque is zero

$$T = 0 \text{ hence } N = \frac{V}{K\phi}$$

and as the load torque increases the speed decreases. Equation (6.15) can be rewritten as

$$y = c - mx$$

where $m = \frac{R_a}{K^2 \phi^2}$ and indicates the slope of the speed torque characteristic

If a resistance R is inserted in series with the armature circuit of the shunt motor for controlling the speed torque characteristic, the equations are

$$V = E_b + I_a(R_a + R)$$

and

$$N = \frac{V}{K\phi} - \frac{T(R_a + R)}{K^2\phi^2} \quad \dots(6.16)$$

The nature of the characteristic is identical to the one given in equation (6.15) except the slope is more negative and of course the no load speed is the same. These characteristics have been shown in Fig. 6.15.

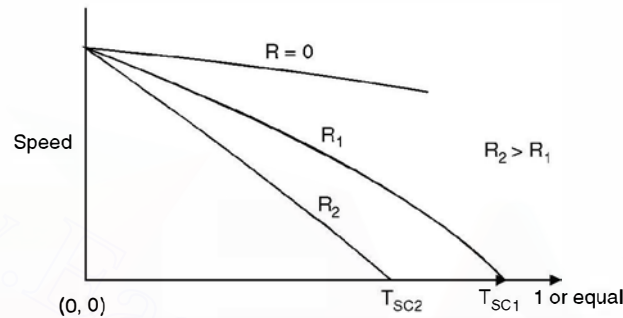

Fig. 6.15. T-speed characteristic of dc shunt motor.

In fact for a dc shunt motor without any control (neither armature nor field) the drop in speed from no load to full load is so small that the shunt motor can be considered as a constant speed motor. In Fig. 6.15 T_{sc1} and T_{sc2} indicate the stalling torques of the motor for resistances R_1 and R_2 respectively and the corresponding armature currents will be

$$I_{sc1} = \frac{V}{R_a + R_1} \quad I_{sc2} = \frac{V}{R_a + R_2} \quad \dots(6.17)$$

Since dc shunt machine is a constant flux machine the relation between speed and I_a and T and I_a are shown in Fig. 6.16, using relation (6.14) and (6.12) respectively

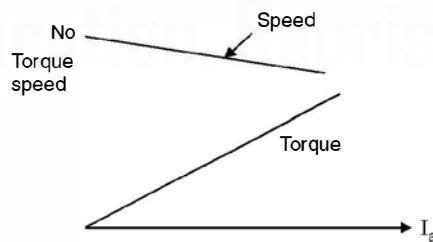

Fig. 6.16. Speed, I_a and Torque/ I_a characteristic of dc shunt motor.

The speed vs armature current characteristic can be obtained by connecting a rheostat in series with armature circuit and keeping the load constant. This is known as armature control of speed. The other method is field control, by inserting a resistance in the field circuit. In the armature control, speeds less than the no load speed are obtained whereas in field control (Fig. 6.17) the speeds more than the normal speed are obtained.

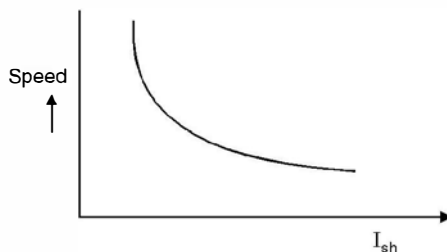

Fig. 6.17. Field control of speed for shunt motor.

6.7.2 DC Series Motor

In case of dc series motors, under unsaturated conditions, the field flux is proportional to the armature current. The equation describing the performance under such conditions is given as

$$V = E_b + I_a R_a = K\phi N + I_a R_a$$

and

$$T = K_1 \phi I_a = K_1 I_a^2 \quad \text{or} \quad I_a = \sqrt{\frac{T}{K_1}}$$

Therefore,

$$\begin{aligned} V &= K\phi N + I_a R_a = K I_a N + I_a R_a \\ &= I_a (KN + R_a) = \sqrt{\frac{T}{K_1}} (KN + R_a) \end{aligned}$$

or

$$\begin{aligned} N &= \frac{V}{K} \sqrt{\frac{K_1}{T}} - \frac{R_a}{K} \\ &= \frac{A}{\sqrt{T}} - B \end{aligned} \quad \dots(6.18)$$

where A and B are constants. The characteristic shown in Fig. 6.18 is a hyperbola. From the characteristic it is clear that when a d.c. series motor is started on no load ($T = 0$) the speed is infinite *i.e.* very high speed and the motor may fly into pieces because of mechanical stresses. Therefore a dc series motor is never started on no load.

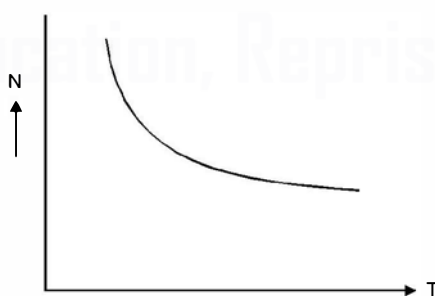

Fig. 6.18. Torque-speed characteristic of dc series motor.

However, if the load current is large *i.e.* the core is saturated

$$V = K\phi N + I_a R_a$$

and

$$T = K\phi I_a$$

Therefore
$$N = A_1 - B_1 T$$

The machine will behave as a shunt machine. The series machine characteristics for speed vs I_a and torque vs I_a are shown in Fig. 6.19. Initially, under unsaturated condition when I_a is small, $T \propto I_a^2$ and after large value of I_a when the machine gets saturated $T \propto I_a$

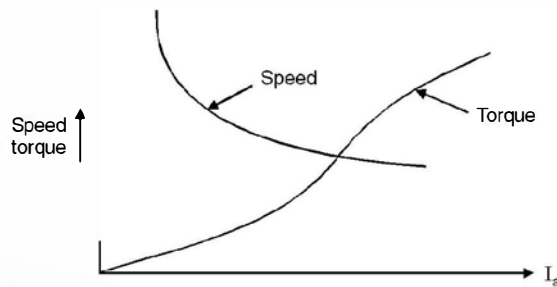

Fig. 6.19. Speed V_s/I_a and torque $V_s I_a$ characteristics for series motor.

The speed torque curve of a dc series motor is very suitable for electric traction and cranes. The starting torque is very high ($T \propto I_a^2$). Therefore, heavy masses can be accelerated very fast. The decrease in speed with increase in torque is a stable operating condition for this motor. When the motor has to go up hill, the torque required increases, hence the speed automatically reduces.

6.7.3 DC Motor Starter

We know that the current drawn by a dc motor is limited by its back emf as this emf opposes the supply voltage and hence the resultant voltage is responsible for the current. This back e.m.f. is proportional to the speed. Hence when the motor is to be started, initially the speed is zero and hence the back emf is zero and hence at start the current is limited only by the armature resist-

ance which usually is in terms of friction of an ohm and the current $I_{ST} = \frac{V}{R_a}$ where V is the supply voltage and the current becomes in terms of hundreds of amperes which may damage the armature winding. Hence a device known as a dc motor starter is invariably used for starting these motors. The starting current can be reduced by inserting a resistance in series with the armature. As the motor is switched on to supply, the current is limited to suitable value by the external resistance and the motor starts running. As the motor picks up speed, back emf is induced which opposes the supply voltage and the external resistance is reduced gradually or in steps such that when the motor has reached its normal rated speed the external resistance is completely cut off. The starter has two additional features, the no-volt coil and over load release coil to protect the motor from damage when operating under abnormal conditions. Out of the various starters available, three-point starter is more commonly used and is discussed next.

Three-Point Starter. The starter consists of a number of resistances connected between studs. The arm of the starter makes contact with these studs and also to two metal arcs. These arcs are connected to the no-volt coil and the overload release to the starter arm. Initially the arm is in the extreme left position and all the resistance elements are in the circuit *i.e.*, in series with the armature circuit. As the motor picks up speed, the arm is gradually moved towards right, cutting out the resistances in step. In the final position the arm is in the extreme right position when the whole of external resistance has been cut out and the motor is directly connected on to the supply. The connection of the starter to the motor is shown in Fig. 6.20. The internal details of the starter are also shown.

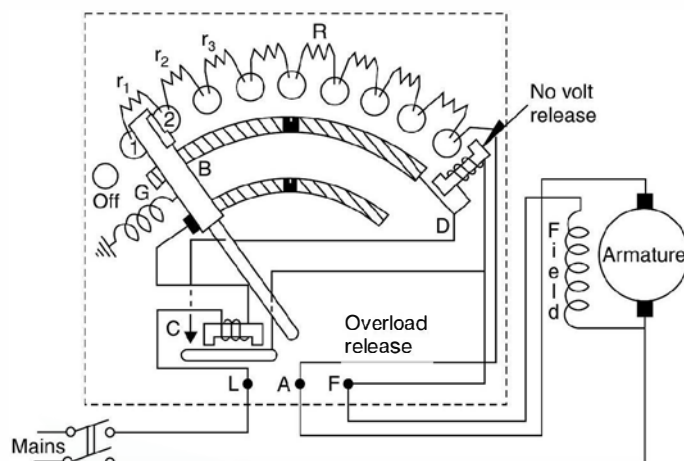

Fig. 6.20. Three point starter for d.c. shunt motor.

The starter has two important features the no-volt release and over load release. Suppose the motor is running under normal condition and suddenly the supply fails. If the starter arm remains in the extreme right condition when no external resistance is inserted in the armature circuit and in the mean time the supply is restored, the armature of the motor will get damaged. However, here no-volt release comes to the rescue of the motor. As soon as the supply fails no volt coil gets de-energised and the starter arm goes back to extreme left position due to spring action.

Similarly when under operating condition if the current drawn by the motor is more than 130% of the full load current the overload release attracts an armature which short circuits the no volt coil and the starter arm is brought back to its extreme left position (off position) and the supply to the motor is disconnected. Thus the motor is saved from overheating.

6.8 LOSSES IN DC MACHINES

Mainly following losses take place in a dc machine :

1. **Copper loss.** These are the I^2R loss and take place in armature conductors ($I_a^2 R_a$), series field winding ($I^2 R_{se}$) and shunt field winding $\frac{V^2}{R_{sh}}$ or $I_{sh}^2 R_{sh}$.
2. **Rotational losses.** In a dc machine, the core loss is a true rotational loss. Except in the pole faces, the flux in the stator remains constant in steady state operation. The flux in the armature core is constantly alternating as the machine rotates and at zero speed the core loss is zero. The rotational loss then consist of the sum of the friction windage and core losses. In a generator or constant speed motor these are considered part of the constant losses.
3. **Brush drop loss.** Brush contact loss occurs due to voltage drop across the brush and is equal to $2V_b I_a$ where V_b is the voltage drop across one brush.
4. **Stray load loss.** We calculate armature copper loss on the basis of dc resistance whereas the current in the armature winding is alternating. An incremental loss should be included to account for skin effect, eddy currents in the conductors and core loss due to

leakage flux in the iron surrounding the armature conductors. The hysteresis and eddy current losses in the pole faces are also somewhat increased at high armature currents. There is no way by which to measure these “stray load” losses. They are often considered negligible in small dc machines. For large machines stray load loss may be taken as 1 per cent of the output power.

6.9 EFFICIENCY OF DC MACHINES

Since it is difficult to measure input for the generator and slightly difficult to measure output at the shaft of a motor, the efficiency of generator and motor is defined as follows :

$$\eta \text{ of a generator} = \frac{\text{Output power}}{\text{Output} + \text{Losses}}$$

and

$$\eta \text{ of a motor} = \frac{\text{Input} - \text{Losses}}{\text{Input power}}$$

The variation of efficiency as a function of load is shown in Fig. 6.21. It is seen that initially the efficiency increases as the load increases and it reaches maximum value around full load and again starts declining.

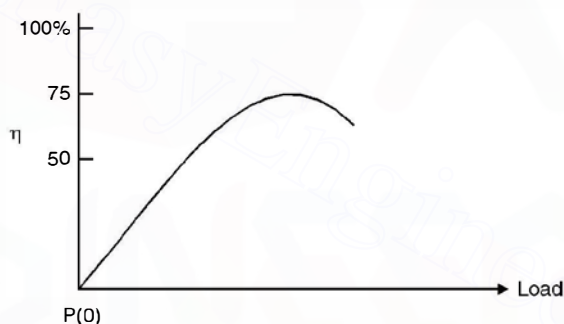

Fig. 6.21. Efficiency curve of a d.c. machine.

Example 6.6. Find the useful flux per pole on no load of a 250 V, 6-pole shunt motor having wave connected armature winding with 110 turns. The armature resistance including brush is 0.2 Ω. The armature current is 13.3 A at no load speed of 908 rpm.

Solution. Total no. of conductors $110 \times 2 = 220 = Z$. Since the armature current under no load is 13.3 A, the load current is zero and hence 13.3 A current flows in the shunt field winding.

The back emf is

$$250 - 13.3 \times 0.2 = 247.36$$

Here $P = 6$, $Z = 220$, $N = 908$, $A = 2$

$$\text{Hence } 247.36 = \frac{\phi ZNP}{60 A} = \frac{\phi \times 220 \times 908 \times 6}{60 \times 2}$$

$$\text{Hence } \phi = 24.8 \text{ mWb } \text{ Ans.}$$

Example 6.7. A direct current shunt motor develops 10 hp at 600 rpm when drawing a line current of 18 A at 500 volts. Find the efficiency at this load and the useful torque.

Solution. $\eta = \frac{\text{Output}}{\text{Input}} = \frac{10 \times 735.5}{18 \times 500} = 0.817$ or 81.7%

Now output $= 2\pi NT = 735.5$

where N is in rps and T in N-m

Hence $T = \frac{735.5}{2\pi \times 10} = 117 \text{ N-m.}$

Example 6.8. A series motor of resistance 1Ω between terminals runs at 800 rpm at 200 V with a current of 15 A. Determine the speed at which it will run when connected in series with a 5Ω resistance and taking the same current at the same supply voltage.

Solution. The back emf $200 - 15 \times 1 = 185 \text{ V}$

In the second case the back emf is $= 200 - 15 \times 6 = 110$ volts

Since the speed is directly proportional to back emf if ϕ is same. Hence the speed in the second case is

$$\frac{110}{185} \times 800 = 476 \text{ rpm Ans.}$$

Example 6.9. An 8 pole generator has 960 armature conductors and a wave winding. The armature current is 100 A. Determine the demagnetising and cross magnetising ampere turns due to armature reaction if

(i) Brushes are along GNP

(ii) Brushes are shifted by 10° electrical degrees

(iii) Brushes are shifted by 10° mechanical from GNP.

Solution. Since it is a wave winding $A = 2$, $I_a = 100 \text{ A}$, $Z = 960$ and $P = 8$.

(i) When brushes are along GNP the demagnetising ampere turns are zero. However cross magnetising

$$\begin{aligned} \text{AT} &= \frac{I_a Z}{2AP} = \frac{100 \times 960}{2 \times 2 \times 8} \\ &= 3000 \text{ AT per pole.} \end{aligned}$$

(i) Shift by 10° electrical

$$\begin{aligned} \text{The demagnetising AT/pole} &= \frac{I_a Z}{AP} = \frac{\theta}{180} = \frac{100 \times 960}{2 \times 8} \times \frac{10}{180} \\ &= 334 \text{ AT/pole} \end{aligned}$$

$$\text{cross magnetising AT/pole} = 3000 - 334 = 2666 \text{ AT/pole}$$

(iii) When shift is 10° mechanical. The equivalent electrical shift.

Mechanical degree \times No. of pair of poles

$$10 \times 4 = 40^\circ$$

Therefore, demagnetising AT/pole

$$\begin{aligned} \frac{I_a Z}{AP} &= \frac{\theta}{180} = \frac{100 \times 960}{2 \times 8} \times \frac{40}{180} \\ &= 1334 \text{ AT/pole} \end{aligned}$$

$$\text{Hence cross magnetising AT/pole} = 3000 - 1334 = 1666 \text{ AT/pole.}$$

Example 6.10. An 8 pole lap wound d.c. machine has 960 armature conductors. The pole covers 70% of the pole pitch. Determine the number of conductors of compensating winding in each pole face.

Solution. No of armature conductors per pole $\frac{960}{8} = 120$

Number of active armature conductor $= 0.7 \times 120 = 84$

Hence number of conductors of compensating winding $= \frac{84}{8} = 10.5$
 $\simeq 11$ conductor/pole.

6.10 SWINBURNE TEST

Since it is a no load test to determine losses of the machine, this test is carried on dc shunt motor and not on dc series motors. The connections are made as shown in Fig. 6.22. Here the machine is run as a motor on no load. The input voltage and current are measured with the help of voltmeter and ammeter as shown in Fig. 6.22 and the armature resistance and field resistances are measured using a low voltage source and ammeter and voltmeter. These resistances correspond to ambient temperature. The approximate values of these resistances corresponding to actual operating conditions can be obtained by assuming a temperature rise of say 40°C. The stray load losses are assumed as 1% of the full load output.

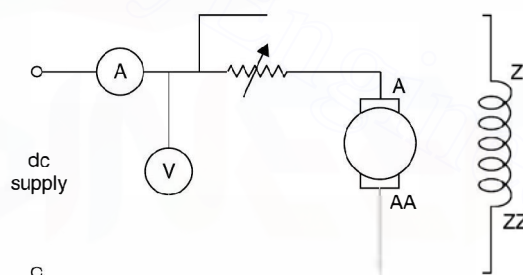

Fig. 6.22. Connection diagram for Swinburne's test.

Let V be the supply voltage, I_0 the input current. R_a, R_f the measured values of armature and field resistances at ambient temperature and R_{a_1}, R_{f_1} the armature and field resistances at operating temperature.

$$\text{Input at no load} = VI_0$$

$$\text{Field copper loss} = \frac{V^2}{R_f}$$

$$\text{Armature copper loss} = \left(I_0 - \frac{V}{R_f} \right)^2 R_a$$

$$\text{Mechanical and iron losses} = VI_0 - \frac{V^2}{R_f} - \left(I_0 - \frac{V}{R_f} \right)^2 R_a$$

Armature copper loss at any load current $I_a^2 R_{a_1}$

$$\text{Field copper loss} = \frac{V^2}{R_{f_1}}$$

Total loss at load = Mechanical and iron losses + Armature copper loss + Field Copper loss + Stray Loss

Swinburne test can thus be utilised to obtain efficiency of the machine at different loadings. However, the test does not provide any information regarding the temperature rise of the windings of the machine.

Example 6.11. Swinburne test gave the following results on a dc shunt motor:

Supply voltage 500 V, no load current 5 A, Armature resistance 0.5 Ω and Field resistance 250 Ω . Determine the efficiency of the machine (i) as a generator delivering 100 A at 500 V (ii) as a motor having a line current of 100 A at 500 V. Neglect temperature rise during operation. Assume stray losses at 1% of output.

Solution. Input at no load

$$500 \times 5 = 2500 \text{ watts}$$

$$\text{Field current } I_f = \frac{500}{250} = 2 \text{ A}$$

Hence armature current $5 - 2 = 3 \text{ A}$

$$\text{Field copper loss} = 2^2 \times 250 = 1000 \text{ watts}$$

$$\text{Armature copper loss} = 3^2 \times 0.5 = 4.5 \text{ watts}$$

$$\begin{aligned} \text{Mechanical and iron loss} &= 2500 - 1000 - 4.5 \\ &= 1495.5 \text{ watts} \end{aligned}$$

(i) Working as a generator

$$\text{Output power} = 500 \times 100 = 50,000 \text{ watts}$$

$$\text{Armature current } 100 + 2 = 102 \text{ A}$$

$$\text{Armature copper loss} = 102^2 \times 0.5 = 5202 \text{ watt}$$

$$\text{Stray loss} = \frac{1}{100} \times 50,000 = 500 \text{ watts}$$

$$\begin{aligned} \text{Total losses} &= 5202 + 1000 + 1495.5 + 500 \\ &= 8197.5 \text{ watts} \end{aligned}$$

$$\text{Hence efficiency} = \frac{50000}{58197.5} = 0.86 \text{ or } \mathbf{86\% \text{ Ans.}}$$

(ii) Working as a motor

$$\text{Input to the motor } 500 \times 100 = 50,000 \text{ watts}$$

$$\text{Armature current } 100 - 2 = 98 \text{ A}$$

$$\text{Armature copper loss} = 98^2 \times 0.5 = 4802 \text{ watts}$$

$$\begin{aligned} \text{Output} &= 50,000 - 4802 - 1000 - 1495.5 \\ &= 42702.5 \text{ watts} \end{aligned}$$

$$\text{Stray loss} = 427 \text{ watts}$$

Hence net output = $42702.5 - 427 = 42275.5$ watts

$$\text{Hence efficiency} = \frac{42275.5}{50,000} \times 100 = 84.55\% \quad \text{Ans.}$$

Example 6.12. A 100 KW belt driven shunt generator running at 300 rpm on 220 V bus bars continues to run as a motor when the belt breaks then taking 10 KW. Determine its speed. Assume armature resistance 0.025Ω , field resistance 60Ω contact drop under each brush 1 V. Ignore armature reaction.

Solution. Current taken by the motor $\frac{10,000}{220} = 45.5$ A

Initially current delivered by the generator 455 A

Hence the induced emf $220 + 455 \times 0.025 = 231.375$

The back emf while motoring $220 - 45.5 \times 0.025 = 218.87$ V

Add 2 volts contact drop in case of generator and subtract 2 volts in case of motor, we have

Total induced emf for generator 233.375 and for the motor back emf 216.87

Hence the speed under motoring condition

$$\frac{216.87}{233.375} \times 300 = 279 \text{ rpm} \quad \text{Ans.}$$

Example 6.13. A series generator, having an external characteristic which is a straight line through zero to 50 V at 200 A, is connected as a booster between a station bus bar and a feeder of 0.3Ω resistance. Determine the voltage between the far end of the feeder and the bus bar at a current of (a) 160 A (b) 50 A.

Solution. (a) Since the generator characteristic is a straight line passing through the origin, at 160 A the bus bar voltage will be

$$\frac{50}{200} \times 160 = 40 \text{ volts}$$

and the drop in the feeder due to the flow of 160 A is

$$160 \times 0.3 = 48 \text{ volts}$$

and hence the difference of volts between the bus bar and the far end of the feeder is

$$48 - 40 = 8 \text{ volts} \quad \text{Ans.}$$

(b) Similarly for 50 A, the bus bar voltage is

$$\frac{50}{200} \times 50 = 12.5 \text{ volts}$$

and the drop in the feeder due to 50 A current flow is

$$50 \times 0.3 = 15 \text{ volt}$$

and hence the difference in voltage is

$$15 - 12.5 = 2.5 \text{ V} \quad \text{Ans.}$$

Example 6.14. A long shunt compound generator delivers a load current of 50 A at 500 V and has armature, series field and shunt field resistances of 0.05Ω , 0.03Ω and 250Ω respectively. Determine the induced emf and the armature current. Allow 1 volt per brush for contact drop.

Solution. The long shunt figure is given here

$$\text{The shunt field current } \frac{500}{250} = 2 \text{ A}$$

$$\text{Hence armature current } I_a = I_L + I_{sh} = 50 + 2 = 52 \text{ A} \quad \text{Ans.}$$

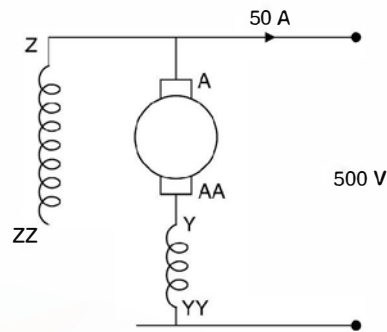

Fig. E6.14

The drop in the armature and the series field resistance

$$52(0.05 + 0.03) = 4.16$$

The brush drop 2 volts. Hence the e.m.f. induced is $500 + 2 + 4.16 = 506.16 \approx 506.2$ volts. **Ans.**

Example 6.15. A 250 V shunt motor on no load runs at 1000 rpm and takes 5 A. The total armature and shunt field resistances are respectively 0.2 Ω and 250 Ω . Determine the speed when loaded taking a current of 50 A, if armature reaction weakens the field by 3%.

$$\text{Solution. The field current is } \frac{250}{250} = 1 \text{ A}$$

Under no load condition the armature current is $5 - 1 = 4$ A. Hence back emf is

$$250 - 4 \times 0.2 = 249.2 \text{ volts}$$

Since the armature current is 4 A which is very small as compared to 50 A as far as armature reaction effect is concerned, hence we neglect the effect.

The back emf when 50 A is drawn by the motor

$$250 - (50 - 1) \times 0.2 = 240.2 \text{ volts}$$

$$\text{Now } 249.2 = K\phi \times 1000$$

$$240.2 = 0.97 K\phi$$

$$\text{Hence } \frac{0.97 K\phi}{K\phi \times 1000} = \frac{240.2}{249.2}$$

$$\text{or } N = \frac{240.2}{249.2} \times \frac{1000}{0.97} \approx 993.7$$

$$\approx 994 \text{ rpm.}$$

Example 6.16. A shunt generator delivers 50 KW at 250 V and 400 rpm. The armature and field resistances are 0.02 Ω and 50 Ω respectively. Determine the speed of the machine running as a shunt motor and taking 50 KW input at 250 V. Allow 1 V per brush for contact drop.

Solution. The load current of the generator

$$\frac{50,000}{250} = 200 \text{ A}$$

$$\text{Field current} \quad \frac{250}{50} = 5 \text{ A}$$

$$\text{Armature current} \quad 200 + 5 = 205$$

$$\text{Armature drop} \quad = 0.02 \times 205 = 4.1 \text{ V}$$

Hence induced emf including brush drop $250 + 4.1 + 2 = 256.1$ volt.

(ii) When input to motor is 50 KW, the line current is 200 A and since field current is 5 A, the armature current is $200 - 5 = 195 \text{ A}$

$$\text{Hence armature drop } 195 \times 0.02 = 3.9$$

$$\text{The net back emf is } 250 - 3.9 - 2 = 244.1 \text{ volt}$$

$$\text{Hence speed as a motor } \frac{244.1}{256.1} \times 400 = 382 \text{ rpm} \quad \text{Ans.}$$

Example 6.17. A direct current shunt motor develops 10.14 metric h.p. at 600 rpm when drawing a current of 18 A at 500 V. Find the efficiency and the useful torque.

Solution. The output power developed is

$$10.14 \times 735 \text{ watts and the input power is}$$

$$500 \times 18 = 9000 \text{ W}$$

$$\text{Hence efficiency of the motor is } \frac{10.14 \times 735}{9000} \times 100 = 82.8\%$$

Now power developed = $2\pi NT$ when N is the speed in rps and T the torque in newton-m.

$$\text{Hence} \quad 10.14 \times 735 = 2\pi \times \frac{600}{60} T$$

$$\text{Hence} \quad T = \frac{10.14 \times 735 \times 60}{2\pi \times 600} = 118.6 \text{ Nm} \quad \text{Ans.}$$

Example 6.18. The armature of a 4-pole shunt motor has a lap winding accommodated in 60 slots, each containing 20 conductors. If the useful flux per pole is 23 mWb, calculate the total torque developed when the armature current is 50 A.

Solution. The power developed by the motor is given by $E_b I_a$ where E_b is the back emf and I_a the armature current.

$$\text{Now} \quad E_b = \frac{\phi ZNP}{60A}$$

$$\text{Here } \phi = 23 \text{ mWb, } Z = 60 \times 20 = 1200, N = ?, P = 4 \text{ and } A = 4$$

Substituting these value we have

$$E_b = \frac{23 \times 10^{-3} \times 1200 N \times 4}{60 \times 4} = 460N \times 10^{-3}$$

$$\frac{2\pi NT}{60} = 460N \times 10^{-3} \times 50$$

$$T = \frac{460 \times 50 \times 10^{-3} \times 60}{2\pi} = 219 \text{ Nm} \quad \text{Ans.}$$

Example 6.19. A shunt generator delivers 200 A at 250 V. The armature resistance and shunt field resistances are 0.02 Ω and 50 Ω respectively. The iron and friction losses equal 950 W. Determine (i) the emf generated (ii) copper losses (iii) output of the prime mover and efficiency of the generator.

Solution. The output power of the generator $250 \times 200 = 50000 \text{ W}$

$$\text{The field current is } \frac{250}{50} = 5 \text{ A}$$

and hence armature current is 205 A

$$\text{The field copper loss } 250 \times 5 = 1250 \text{ Watt}$$

$$\text{Armature copper loss } = 205^2 \times 0.02 = 840.5 \text{ watts}$$

$$\text{Iron and friction loss } = 950 \text{ watts.}$$

$$\begin{aligned} \text{(i) Emf induced } E &= V + I_a R_a \\ &= 250 + 205 \times 0.02 = 254.1 \end{aligned}$$

$$\text{(ii) Total copper loss } = 1250 + 840.5 = 2090.5 \text{ watt}$$

Output of prime mover is the input to the generator.

$$\text{Input to generator } 50,000 + 2090.5 + 950 = 53040.5 \text{ watts}$$

$$\% \eta = \frac{50,000}{53040.5} \times 100 = 94.26\% \quad \text{Ans.}$$

Example 6.20. A 500 V d.c. series motor runs at 400 rpm. The efficiency is 90% and the shaft torque is 195 Nm. Determine the current taken by the motor.

Solution. The power developed by the motor is

$$2\pi NT = 2\pi \times \frac{400}{60} \times 195 = 8164 \text{ watts}$$

$$\text{Input to the motor } \frac{8164}{0.9} = 9071 \text{ watt}$$

Hence the current taken by the motor

$$\frac{9071}{500} = 18.14 \text{ Amp.} \quad \text{Ans.}$$

Example 6.21. A 240 V d.c. series motor takes 40 A when giving its required output at 1500 rpm. Its resistance is 0.3 Ω . Determine the value of resistance to be added to obtain rated torque (a) at starting (b) at 1000 rpm.

Solution. (a) Power input to the motor $240 \times 40 = 9600 \text{ watts}$

$$\text{The copper loss } = 40^2 \times 0.3 = 480 \text{ watts}$$

$$\text{The power developed by the motor } 9600 - 480 = 9120 \text{ watt.}$$

$$\text{The rated torque } T = \frac{9120 \times 60}{2\pi \times 1500} = 58.089 \text{ Nm.}$$

Now for a d.c. series motor $T \propto I^2$

At starting we want the torque to be rated torque *i.e.* the current should correspond to rated torque *i.e.* 40 A. At start since back emf is zero, hence the total resistance required to circulate 40 A is

$$\frac{240}{40} = 6 \Omega$$

and since armature has a resistance of 0.3Ω , the external resistance required is

$$6 - 0.3 = 5.7 \Omega \quad \text{Ans.}$$

(b) The back emf at 1500 rpm is

$$E_b = 240 - 40 \times 0.3 = 228$$

Now for 40 A in armature and at 1000 rpm the back emf would be

$$228 \times \frac{1000}{1500} = 152 \text{ volt}$$

Let R be the external resistance which will circulate a current of 40 A in the armature

$$\text{Hence} \quad \frac{240 - 152}{R + 0.3} = 40 \quad \text{or} \quad \frac{88}{40} = R + 0.3 \quad \text{or} \quad R = 1.9 \Omega \quad \text{Ans.}$$

Example 6.22. A 400 V d.c. motor takes 5 A at no load. Its armature and field resistances are 0.5Ω and 200Ω . Calculate the efficiency when motor takes 40 A on full load.

Solution. The shunt field current is $\frac{400}{200} = 2 \text{ A}$

The shunt field copper loss = $400 \times 2 = 800 \text{ watts}$

The input to the motor on no load $400 \times 5 = 2000 \text{ W}$

Assuming armature copper loss to be negligible under no load condition, the rotational and stray losses are $2000 - 800 = 1200 \text{ watts}$.

If the full load current is 40 A, the power input to motor is $400 \times 40 = 16000 \text{ watts}$.

Armature current is $40 - 2 = 38 \text{ A}$

and hence armature copper loss = $38^2 \times 0.5 = 722 \text{ watt}$

Total loss = $722 + 1200 + 800 = 2722$

Hence output from the motor $16000 - 2722 = 13278$

The $\% \eta = \frac{13278}{16000} \times 100 = 83\% \quad \text{Ans.}$

PROBLEMS

- 6.1. Describe the construction of a dc machine and explain what materials are used for each component of the machine.
- 6.2. Explain the functions of brushes and commutator in a dc machine.
- 6.3. Why are some parts of a dc machine laminated ?
- 6.4. State the purpose of the following :

(a) Armature winding	(b) Armature core
(c) Field winding	(d) Pole shoes
(e) Pole core	(f) Commutator.

- 6.5. What things distinguish motor action from generator action in a dc machine ?
- 6.6. Derive emf equation for a d.c. machine.
- 6.7. Derive an expression for the torque developed by a dc motor.
- 6.8. Classify the dc machine based on excitation systems.
- 6.9. Explain with a neat diagrams how you obtain magnetisation characteristic of a dc machine and explain the significance of the characteristic.
- 6.10. What is meant by self excitation of a dc generator ? Discuss requirements for self-excitation.
- 6.11. Draw and discuss external (load) characteristics of (i) shunt (ii) series and (iii) compound dc generators.
- 6.12. Derive mathematically torque-speed characteristic of various dc motors. Draw the curves and discuss them.
- 6.13. Discuss various losses in a dc machine.
- 6.14. A 4-pole generator has a flux of 40 mWb per pole and a lap connected armature with 740 conductors. Determine the emf generated on open circuit at 1000 rpm. [Ans. 494 V]
- 6.15. A 4-pole shunt generator with lap connected armature having field and armature resistances of 50Ω and 0.1Ω respectively supplies sixty 100 V 40 watt lamps. Calculate the total armature current, the current per armature path and the generated emf. Allow a contact drop of 2 volts. [Ans. 26 A, 6.5 A 104.6 V]
- 6.16. A 4-pole, 500 V, shunt motor has 720 wave connected conductors on its armature. The full load armature current is 60 A and the flux per pole 0.03 Wb. The armature resistance is 0.2Ω and the contact drop is 1 V per brush. Calculate the full load speed of the motor. [Ans. 675 rpm]
- 6.17. A 4-pole generator supplies a current of 143A. It has 492 armature conductors
 (i) Wave connected
 (ii) Lap connected. The brushes are given an actual shift of 10° . When the generator is delivering full load. Determine the demagnetising ampere turns per pole. The field winding is shunt connected and takes 10A. Determine the no. of extra shunt field turns necessary to neutralise the demagnetisation. [Ans. (i) 1040, 104 turns (ii) 520, 52 turns.]
- 6.18. A 500V shunt motor takes 4 A on no load. The armature resistance including that of the brushes is 0.2Ω and the field current is 1 A. Determine the output and efficiency when the input current is (i) 20 A (ii) 100 A. [Ans. (i) 10.75 h.p. 79.3%, (ii) 62.7 h.p. 92.1%]
- 6.19. A 480 V, 25 hp shunt motor took 2.5 A when running light. Taking armature resistance to be 0.6Ω , field resistance 800Ω and brush drop 2 V, find the full load efficiency. [Ans. 0.885]
- 6.20. Describe with neat sketches the construction of armature, field magnet and commutator of a dc machine.
- 6.21. Why are some parts of a dc machine laminated and which parts are laminated ?
- 6.22. Explain the process of commutation in a dc machine. What causes sparking on the commutator surface ? How can it be minimised.
- 6.23. Explain the conditions required for self excitation of a dc generator.
- 6.24. Explain with neat diagram how you conduct Swinburne's test on a d.c. machine. What information you gather from this test.
- 6.25. Derive speed torque characteristics of (a) d.c. shunt motor (b) d.c. series motor and discuss their application.
- 6.26. Derive speed current and torque current characteristics of (a) d.c. shunt and (b) d.c. series motors.
- 6.27. Explain with the help of neat sketches a three-point starter. Why a starter is required for starting a motor ?
- 6.28. A d.c. shunt motor is running at normal speed and suddenly it picks up very high speed. Give reason.

CHAPTER

7

Three-Phase Synchronous Machines

7.1 INTRODUCTION

Synchronous machines are called “synchronous” as their speed is directly related to the line frequency.

$$n_s = \frac{120f}{p} \text{ rev/m}$$

where n_s is the synchronous speed in rpm, p the number of magnetic poles designed into each machine and f is the frequency in Hz of the supply voltage. Thus when two or more synchronous machines are connected to the same supply line, they will all run in synchronism because they are all operating at the same supply frequency. Of course, if one machine has 2 poles (Turbo-alternators) and another has 12 poles, the 12-pole machine will run at precisely $\frac{1}{6}$ th the speed of the 2-pole machine.

7.2 CONSTRUCTION

Rotating machines have an outside (stationary) part called the stator. The inner (rotating) part is called the rotor. The rotor is centred within the stator so that the rotor axis is concentric with that of the stator. The space between the outside of the rotor and inside of the stator is called the air gap.

The rotor is mounted on a stiff rod (usually steel) called a shaft. The shaft is supported in bearings so that the rotor is free to rotate. The shaft extends through one or both of the bearings to provide a means to connect the machine to the mechanical system. It is to be noted that the rotor is solidly fastened to the shaft so that the rotor and the shaft rotate at the same speed. Therefore, the terms ‘rotor speed’, ‘shaft speed’ or machine speed all mean the same thing and are used interchangeably.

The rotor and stator each have three basic parts, the core, the windings and the insulation. Thus, it is proper to speak of “the rotor core”, ‘the stator windings’ ‘the rotor insulation’ and so on. The purpose of the rotor and stator cores is to conduct the magnetic field through the coils of the windings. The cores are almost always made of iron or steel.

The stator winding is known as armature winding as it carries the load current whereas the rotor winding is known as field winding as this winding provides exciting current or magnetising

current. Since the armature winding carries load current, it has to handle all of the power being converted or transformed by the device, however, the magnetising power requirement is relatively small. The steady state power input to a field winding is only about $\frac{1}{2}$ to 2 per cent of the rated power of the machine. The input power to dc field winding is all consumed as I^2R loss except during transient period which lasts for almost a second or two during which energy is being stored in magnetic field.

The winding conductors are either of copper or aluminium and that could be in the form of coils of wire or heavy bars depending upon the current carrying capacity required. Also each winding consists of several coils or bars in series or in series-parallel combination depending upon the voltage and current requirements of the machine. The ends of certain of the windings are brought out to terminals to allow easy connection to the electrical system.

In some machines, the windings of either the rotor or the stator may be placed around projecting magnetic pole pieces, called salient poles (salient means prominent). When a core has salient poles the coils of the winding are wound around the waists of the pole pieces. These narrower parts of the salient poles are called the pole cores. The shaped ends of the poles are called the pole shoes. Their purpose is to provide the correct flux density distribution in the air gap. Salient poles are used on the stator cores of dc machines and on the rotor cores of many synchronous machines and in both cases they carry dc field windings. The mechanical weakness and air resistance of salient poles prohibit their use on rotors of large high speed synchronous generator designed to be driven by steam or gas turbines. Turboalternators as these are usually called always have cylindrical rotors with the field windings embedded in slots cut into the rotor surface. A machine having both its rotor and stator windings in slots is known as round rotor machine or non-salient pole machine.

The insulation system consists of (i) the conductor or wire insulation *e.g.* superenamelled wires or conductors ; (ii) the coil insulation usually some kind of tape or several layers of tapes depending upon operating voltage ; and (iii) the slot lines when the windings consist of coils that are located in slots, the coils are held in place in the slots by slot wedges. The insulation system thus prevents short circuits between turns of a given winding coil and insulate the winding from the iron core which is always grounded for safety's sake. The insulation system must protect the machine against damage due to overvoltages and overcurrents that may occur during the operation of the machine.

7.2.1 EMF Equation

Elementary idea about generation of 3-phase voltages has already been discussed in article 3.1 of the book.

To derive emf equation consider a two pole generator and the armature winding is a single N -turn coil where coil sides are placed in diametrically opposite slots on the inner periphery of the slot as shown in Fig. 7.1. The coil spans a full 180 electrical degrees or a complete pole pitch and hence is a full pitch coil. When the rotor magnetic axis coincides with the stator magnetic axis the flux cut by the coil is maximum as the stator magnetic axis is normal to the plane containing the coil. As rotor rotates through an angle θ in time t from this position anticlockwise, the component of the rotor flux along the stator magnetic axis is cosine of the angle. Hence the field winding on the rotor produces a sinusoidal space wave (note that the stator coil is fixed in space) of flux

density B at the stator surface *i.e.* $B = B_m \cos \theta$. When rotor and stator magnetic axes coincide, the flux linkage with the stator coil is $N\phi$ where ϕ is the air gap flux per pole. For a two pole generator angle θ in electrical and mechanical degrees is same. Otherwise it is the angle in electrical degrees. The air gap flux per pole is the integral of the flux density over the pole area. Thus for a two pole

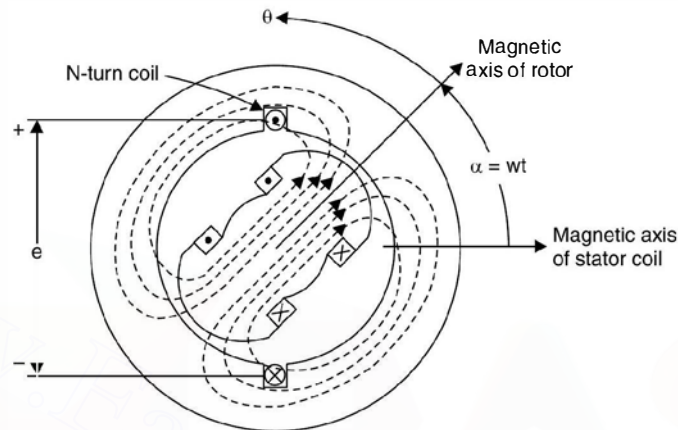

Fig. 7.1. Elementary 2-pole ac machine with stator coil of N turns.

$$\phi = \int_{-\pi/2}^{\pi/2} B_m \cos \theta \cdot l \cdot r \, d\theta = 2B_m l r \quad \dots(7.1)$$

where l is the axial length of the stator and r its radius at the air gap. For a P pole machine

$$\phi = \frac{2}{P} \cdot 2B_m l r \quad \dots(7.2)$$

as the pole area is $\frac{2}{P}$ times that of the 2-pole machine of the same length and diameter.

As the rotor rotates at constant speed the flux linkage to the stator coil is

$$\lambda = N\phi \cos \theta = N\phi \cos \omega t \quad \dots(7.3)$$

where t is reckoned from the instant when the rotor magnetic axis coincides with stator magnetic axis. Using Faraday's law of electromagnetic induction, the voltage induced in the stator coil is

$$e = - \frac{d\lambda}{dt} = \omega N\phi \sin \omega t - N \frac{d\phi}{dt} \cos \omega t \quad \dots(7.4)$$

The minus sign associated with Faraday's law in equation (7.4) implies generator reference direction as shown in Fig. 7.1. That is while the flux linking the coil is decreasing, an emf will be induced in it in a direction to try to produce a current which would tend to prevent the flux linking it from decreasing.

Since in a 3-phase alternator the field on the rotor is due to the dc current which is of constant magnitude hence the second term in equation 7.4 can be ignored. The first term on the right hand side, of equation 7.4, however is a speed voltage due to relative motion of the field and the coil.

Hence retaining this term we have

$$e = \omega N\phi \sin \omega t \quad \dots(7.5)$$

Therefore, the peak value of the induced voltage is

$$E_m = 2\pi f N\phi$$

or the r.m.s. value of the induced voltage is

$$E = \frac{2\pi}{\sqrt{2}} f N\phi = 4.44 f N\phi \quad \dots(7.6)$$

Equation (7.6) is identical in form to the emf equation of the transformer. Relative motion of a coil and a constant magnitude spatial flux density wave in a rotating machine produces the same voltage effect as does a time varying flux in association with stationary coils in a transformer.

Rotation, therefore, introduces the time element and transforms a space distribution of flux density into a time variation of voltage.

Equation (7.6) indicates that voltage induced is a single phase voltage. For the production of 3-phase voltages we need three coils displaced 120 electrical degrees in space. Here we have assumed that the coil spans full pole pitch that is the two sides of the coil are 180° electrical apart and all the turns of the coil are concentrated in one pair of slots. In actual practice the armature coils of each phase are distributed in a number of slots. When the coils comprising a phase of the winding are distributed in two or more slots per pole, the emfs in the adjacent coil will be out of phase with respect to one another and their resultant will be less than their algebraic sum. In other words, when the N turns of a concentrated winding are spread out the resultant emf will be less than what is given in equation (7.6) and the factor (less than unity) by which the latter must be multiplied in order to obtain the actual emf is called the breadth factor, denoted by K_b and is given as

$$K_b = \frac{\sin(q\gamma/2)}{q \sin \gamma/2}$$

where q is the number of slots for pole per phase and γ is the angle in electrical degrees between the adjacent slots and equals 180 electrical degrees divided by the number of slots per pole. Equation (7.6) is modified as

$$E = 4.44 K_b f \phi N \quad \dots(7.7)$$

A distributed winding makes better use of the iron and copper and improves the waveform.

Equation (7.7) presumes that the coils are full pitched *i.e.*, the two sides are 180° electrical degree apart.

If the angle between the two sides of the coil is less than 180 electrical degrees, it is known as short pitched coil and the voltage in the two sides are not same. This is also known as chording of coil. If the chording is say by an angle ρ , the effective voltage will be multiplied by a factor $\cos \rho/2$ and is known as pitch factor denoted by K_p and therefore if the winding is distributed and short pitched, equation (7.6) is modified to equation 7.8 as given here

$$E = 4.44 K_p K_b \phi f N \quad \dots(7.8)$$

The short pitched coils are extensively used for the reason that the waveform is more nearly sinusoidal (Harmonics are eliminated) than with full pitch windings and because of the saving in copper and the greater stiffness of the coils due to the shorter end connections. The latter reason is more important in the case of two pole high speed turbo alternators because of the bending stresses produced in the end connections under short circuit conditions.

Derivation of pitch factor

Suppose the two coil sides are 180° electrical apart *i.e.* one side is say under north pole the other is under south pole, the emf in the two coils will be as shown in Fig. 7.2 (a).

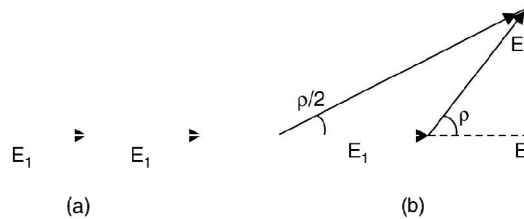

Fig. 7.2

However, if one side is placed under north pole and the other side at an electrical angle $(180 - \rho)$ apart, the two emf will be as shown in Fig. 7.2 (b).

The net voltage will be

$$2E_1 \cos \rho/2$$

Hence the pitch factor is $\cos \rho/2$.

7.2.2 Rotating Magnetic Field

In order to understand the operation of 3-phase ac machines, it is essential to understand the magnetic field produced by currents in the three phases of the stator winding. We will study the mmf pattern of a 3-phase winding such as those found on the stator of 3-phase induction and synchronous machines. We will consider here a 2-pole machine with six slots so that each phase winding is concentrated in slots 180° electrical apart. Since it is a 2-pole machine, six slots will be considered *i.e.*, 2-slots per pole as shown in Fig. 7.3.

Now consider the situation at $t = 0$. Fig. 7.3 (a) the moment when current in phase *a* is at its maximum value. The mmf of phase *a* then has its maximum value F_{\max} , perpendicular to the plane of the coil *aa'* as shown in Fig. 7.3 (a) and is drawn along the magnetic axis of phase 'a'.

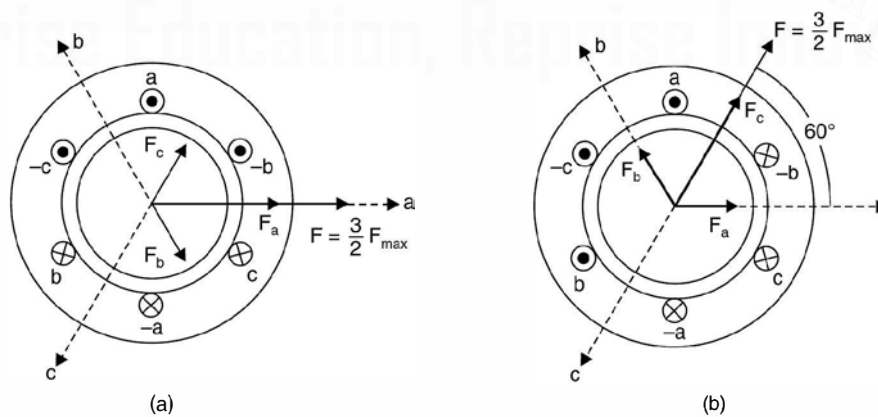

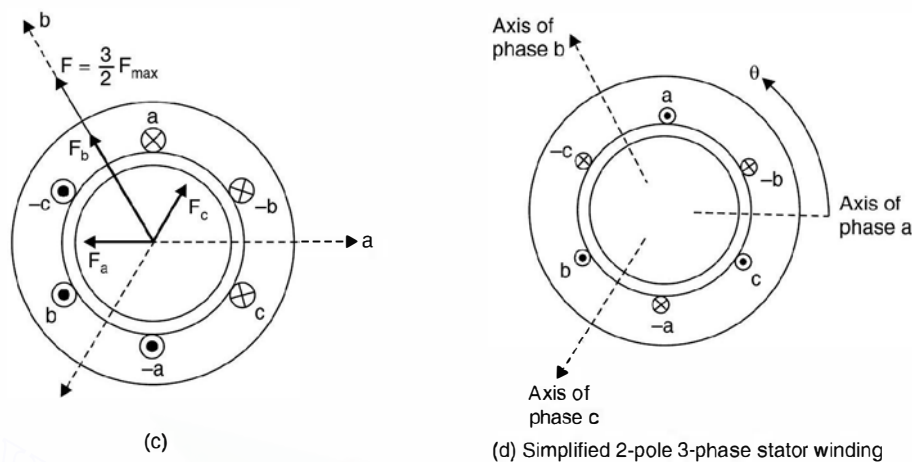

Fig. 7.3. Illustrating the production of a rotating magnetic field by means of 3-phase currents. Simplified 2-pole 3-phase stator winding.

At this moment the currents i_b and i_c are both $I_m/2$ in the negative direction as shown in the phasor diagram which is the actual instantaneous direction. The corresponding mmfs of phase *b* and *c* are shown by the phasors F_b and F_c both equal to $F_{\max}/2$ drawn in the negative direction of respective magnetic axes. The resultant is obtained by taking the phasor sum of the three phasors which comes to $\frac{3}{2} F_{\max}$ centred along the magnetic axis of phase *a*.

It represents a sinusoidal space wave with its positive half wave centred on the axis of phase *a* and having an amplitude $\frac{3}{2}$ times that of the phase *a*.

Consider the instant t_1 such that $\omega t_1 = \frac{\pi}{3}$, as shown in Fig. 7.3 (b) the currents in phase *a* and *b* are a positive half-maximum and that in phase *c* is a negative maximum as shown in corresponding phasor diagram. The individual mmf components and their resultant are shown in Fig. 7.3 (b). The resultant has the same magnitude as at $t = 0$ but it has now rotated anticlockwise 60° electrical in space. Similarly at $\omega t_2 = \frac{2\pi}{3}$ when phase *b* current is a positive maximum and the phase *a* and *c* currents are a negative half maximum (see phasor diagram), the same resultant mmf distribution is obtained but it has rotated another 60° in anticlockwise direction and now it is along magnetic field axis of phase *b*. With passage of time the resultant mmf wave retains its sinusoidal form and amplitude but shifts progressively around the air gap. This shift corresponds to a field rotating uniformly around the circumference of the air gap.

In one cycle the resultant mmf comes back in the position of Fig. 7.3 (a). The mmf wave, therefore, makes one revolutions per cycle in a 2-pole machine and in one cycle the rotor has moved one complete revolution in a 2-pole machine and hence in a *P*-pole machine the wave

travels one wavelength or $\frac{2}{P}$ revolutions per cycle. Therefore, the mmf wave rotates at synchronous speed in space and its constant magnitude equals 1.5 times the maximum mmf of one phase.

Analytical method : Consider Fig. 7.3 (d) where the phase a magnetic axis is taken as reference and consider the instant when the mmf of phase has moved through an angle θ when the magnitude of mmf of phase a is $F_{a \text{ peak}}$, those of phase b and c are $F_{b \text{ peak}}$ and F_c respectively.

Taking the components of mmf due to all the three phases along the reference axis, the total mmf along the axis is

$$F(\theta) = F_{a \text{ peak}} \cos \theta + F_{b \text{ peak}} \cos (\theta - 120) + F_{c \text{ peak}} \cos (\theta - 240) \quad \dots(7.9)$$

However, the amplitudes of the mmf vary with time in accordance with the variation of current. Thus with the time origin arbitrarily taken as the instant when the phase a current is a positive maximum.

Hence

$$\begin{aligned} F_{a \text{ peak}} &= F_{a \text{ max}} \cos \omega t \\ F_{b \text{ peak}} &= F_{b \text{ max}} \cos (\omega t - 120^\circ) \\ \text{and} \quad F_{c \text{ peak}} &= F_{c \text{ max}} \cos (\omega t - 240^\circ) \end{aligned}$$

Here 120° phase displacement is due to displacement of current in the three phases and since the currents are balanced $|I_a| = |I_b| = |I_c|$ and hence

$$F_{a \text{ max}} = F_{b \text{ max}} = F_{c \text{ max}} = F_{\text{max}} \text{ say}$$

Hence equation (7.9) can be rewritten as

$$F(\theta) = F_m \cos \theta \cos \omega t + F_m \cos (\theta - 120) \cos (\omega t - 120) + F_m \cos (\theta - 240) \cos (\omega t - 240)$$

Now using the trigonometric relation

$$\cos \alpha \cos \beta = \frac{1}{2} [\cos (\alpha - \beta) + \cos (\alpha + \beta)]$$

we have

$$\begin{aligned} F(\theta) &= \frac{F_m}{2} [\cos (\theta - \omega t) + \cos (\theta + \omega t)] \\ &\quad + \cos (\theta - 120 - \omega t + 120) + \cos (\theta - 120 + \omega t - 120) \\ &\quad + \cos (\theta - 240 - \omega t + 240) + \cos (\theta - 240 + \omega t - 240)] \\ &= \frac{F_m}{2} [\cos (\theta - \omega t) + \cos (\theta + \omega t) + \cos (\theta - \omega t) + \cos (\theta + \omega t - 240) \\ &\quad + \cos (\theta - \omega t) + \cos (\theta + \omega t - 480) \quad \dots(7.10) \end{aligned}$$

Now the three terms in the above equation involving the angle $\theta + \omega t$, $(\theta + \omega t - 240)$ and $(\theta + \omega t - 480^\circ)$ sum to zero as these are three phases displaced in phase by 120° . Note that the term $\theta + \omega t - 480^\circ$ is equivalent to $(\theta + \omega t - 120^\circ)$.

Therefore, the equation (7.10) reduces to

$$F(\theta) = \frac{3F_m}{2} \cos (\theta - \omega t) \quad \dots(7.11)$$

which is a desired expression for the resultant mmf wave.

The wave described by equation 7.11 is a sinusoidal function of the space angle θ . It has a constant amplitude and space-phase angle ωt which is a linear function of time. The angle ωt provides the rotation of the entire wave around the air gap at the constant angular velocity ω rad/sec.

7.2.3 Armature Reaction

We have studied the effect of armature reaction on the flux in the air gap in case of dc machine in article 6.3.1. Similarly armature reaction has effect on the air gap flux in case of synchronous machines also. We know that when current flows through armature conductors it gives rise to magnetic flux encircling these conductors and hence this certainly will affect the distribution of flux in the air gap due to the rotor flux.

In general the induced emf and current will not be in phase.

Depending upon the p.f. of the load we can however, decompose the load current into two components, one will be in phase with the induced emf whereas the other will lag or lead the voltage by 90° electrical depending upon whether the p.f. is lagging or leading. In case of a motor ; however, one of the component will be in phase opposition to the emf and the other in quadrature with the emf. Thus in a simple generator shown diagrammatically in Fig. 7.4 the coil sides AB will be directly under the middle of the pole faces when the emf. has its maximum value, and the in-phase component of current will also be at its maximum value in this position shown in (a).

If the quadrature component of current is lagging by 90° the emf, the component of current will reach its maximum value when the coil has moved 90° electrical from position (a) to position (b) ; but if the quadrature component is leading, it reaches its maximum 90 electrical degrees prior to position (a) as shown at c.

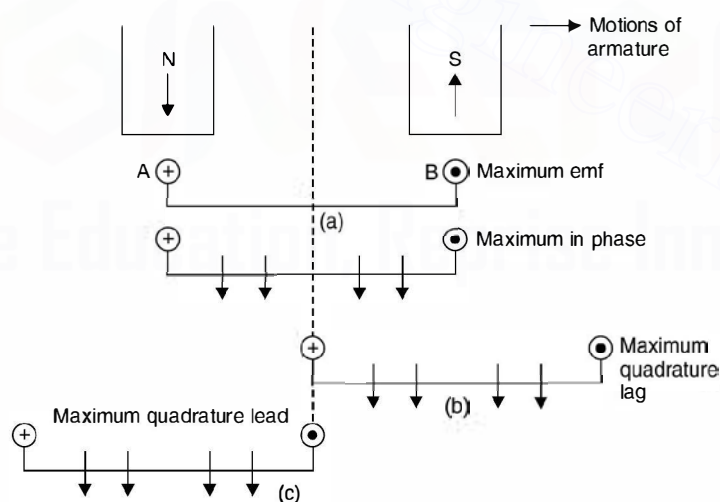

Fig. 7.4. Effect of armature reaction (generator).

As determined by Fleming's right hand rule, the dots and crosses indicate the direction of current flow in the conductors. It is to be noted that the in-phase component of current magnetises along an axis midway between the main pole in such a manner that the main flux tends to increase at the trailing pole tips and to decrease at the leading pole tips. In other words, this is a

cross-magnetising action exactly as in case of a dc generator. On the other hand, the lagging quadrature component of current magnetises in direct opposition to the main flux and the leading quadrature component of current aids the magnetisation of the flux under the main poles *i.e.*, the lagging current has demagnetising effect on the flux in the air gap whereas the leading component of current has magnetisation effect on the air gap flux in case of a generator.

Consider Fig. 7.5 for the effect of armature reaction on the flux in the air gap due to main poles.

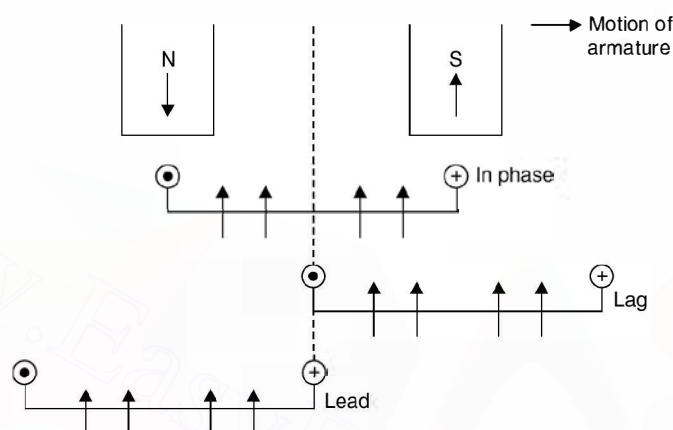

Fig. 7.5. Magnetising effect of in-phase and quadrature current component (motor).

The position of maximum emf is same both in Fig. 7.4 (generator) and Fig. 7.5 (motor) but since in case of motor the induced emf acts as counter. emf or back emf the in-phase current must be in phase opposition. It is seen from Fig. 7.5 that in-phase component weakens the trailing tips of the poles whereas the leading tips of the poles are strengthened just as in dc motors. Also, it is seen that the lagging component of current strengthens the flux under the main poles whereas the leading flux weakens the flux under the main poles.

The effect of armature reaction on the flux in the air gap can be summarised as follows :

1. For a generator the lagging current weakens the flux in the air gap whereas for a motor it strengthens.

2. For a generator the leading current strengthens the flux in the air gap whereas for a motor it weakens the flux in the air gap.

Therefore, for a constant terminal voltage we need more excitation current in case of a generator when the p.f. is lagging whereas we need smaller excitation when the p.f. is leading. The reverse is the case for a synchronous motor.

7.2.4 Open Circuit and Short Circuit Tests on Alternator

The single phase representation of equivalent circuit of an alternator is shown in Fig. 7.6.

Here E represents the induced emf X_a is the armature reactance equivalent of armature reaction (the armature reaction under lagging p.f. decreases the main flux and hence decreases the voltage induced. Hence an equivalent voltage drop across X_a represents that reduction in voltage), R_a is the armature resistance and X_l is the leakage reactance. The sum of X_a and X_l is known as synchronous reactance and the total impedance $R_a + j(X_a + X_l)$

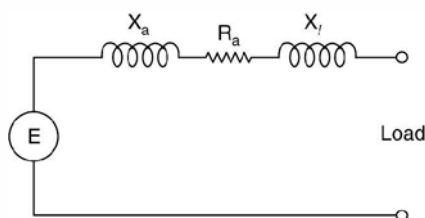

Fig. 7.6. Equivalent circuit of an alternator.

$$Z_s = R_a + jX_s$$

is known as the synchronous impedance. The impedance is known as synchronous as the reactance depends upon the frequency, and frequency of this corresponds to the synchronous speed and hence the name synchronous impedance. The synchronous impedance can be measured by performing open circuit and short circuit tests on the alternator.

Fig. 7.7 shows a common circuit diagram for performing both the tests.

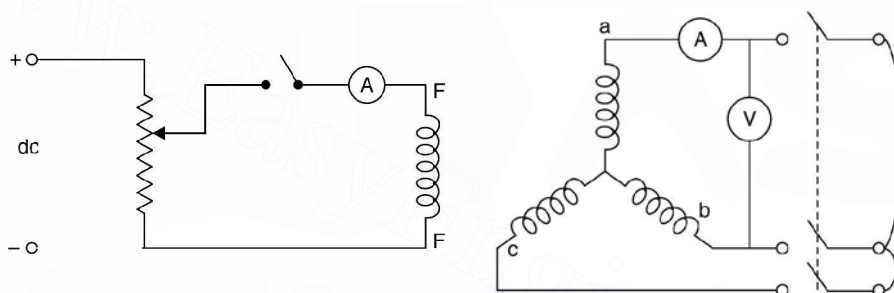

Fig. 7.7. Circuit diagram for performing OC and SC Tests.

Here FF indicates the field winding of the alternator. The armature is star connected and a triple pole single throw switch connects ammeter and voltmeter to armature terminals as shown in the Fig. 7.7.

To perform OC test the switch is left open and voltmeter is thus connected to the alternator which reads line to line voltage. The alternator is run at synchronous speed with the help of a prime mover. A dc shunt motor if coupled to the generator can work as a prime mover. The field switch is left open to record voltage due to residual magnetism when the field current is zero. Now close the field switch and keep the potential divider at minimum voltage position.

Increase the field current gradually and for every field current note down the corresponding induced emf. Continue till the voltage is slightly (10 to 20%) more than the rated voltage.

Plot the variation of voltage as a function of field current keeping the speed constant all along.

Next to perform the SC test run the machine at synchronous speed and bring the potential divider to its minimum position and close the triple pole switch. Adjust the field current such that the ammeter reads a little higher than the full load current of the alternator. Since under short circuit condition the core is unsaturated, the characteristic (SC) is a straight line passing through the origin and, therefore, one single observation is good enough.

Plot this characteristic on the same sheet where we have drawn the OC characteristic as shown in Fig. 7.8.

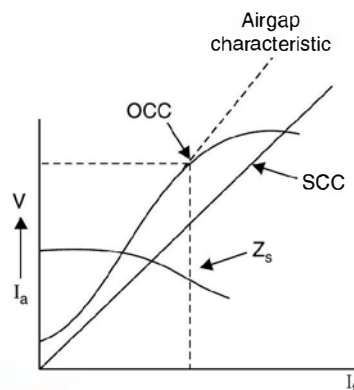

Fig. 7.8. OCC and SCC of the alternator.

The open circuit characteristic will usually be more or less saturation characteristic beyond the rated voltage of the alternator because of saturation of the iron part of the magnetic circuit ; but the initial straight part of the curve, if extended yields the air gap characteristic since it represents the relation between the voltage (and, therefore, the air gap flux) for the condition of zero reluctance of the iron.

If now the voltage ordinate corresponding to any value of field excitation is divided by the short circuit current for the same excitation, the quotient is the synchronous impedance or reactance. Repeating this procedure for several values of excitation the curve of synchronous impedance can be obtained which is shown in Fig. 7.8.

$$Z_s = \frac{\text{OC voltage for some field current}}{\text{SC current for same field current}}$$

If the OC characteristic were a straight line the synchronous impedance would be constant. Actually, it is variable, decreasing with increasing values of excitation.

If the OC voltage is taken along the straight line of the OCC, the synchronous impedance calculated from the current will be too large and if the voltage regulation of the alternator is computed using this value of synchronous impedance, the computed regulation is poorer than it is in actual practice, thus giving rise to the designation pessimistic method. Since the rated voltage of the alternator is near the knee of the OCC characteristic, corresponding to that the short circuit current is found from the plot and the ratio of the two should be used as the synchronous impedance for voltage regulation calculations.

7.2.5 Voltage Regulation

When an alternator is loaded, the terminal voltage of the alternator changes depending upon the magnitude of load and its power factor. The change in voltage is due to the armature resistance leakage reactance and armature reaction. The voltage regulation is defined as the rise in terminal voltage expressed in percent of rated terminal voltage when the load current is reduced to zero, the field excitation and frequency remaining constant.

Thus

$$\% \text{ voltage regulation} = \frac{|E| - |V|}{|V|} \times 100$$

The term rise in voltage used in the above definition assumes that the load is inductive.

However, if the load is capacitive *i.e.*, the load is supplying lagging vars to the generator and hence the excitation required is reduced and hence $|E|$ is reduced and the terminal voltage will be higher when the load is connected as compared to when the load is reduced to zero. In such a situation the voltage regulation is negative.

If we compare the equivalent circuit of an alternator as shown in Fig. 7.6 with that of the approximate equivalent circuit of a transformer as shown in Fig. 5.13 we find that both represent identical features and are a series combination of R and X. The physical interpretation of R and X may be different. We draw the phasor diagram for an alternator both for lag and lead p.f. as shown in Fig. 7.9, using of course the equivalent circuit of Fig. 7.6.

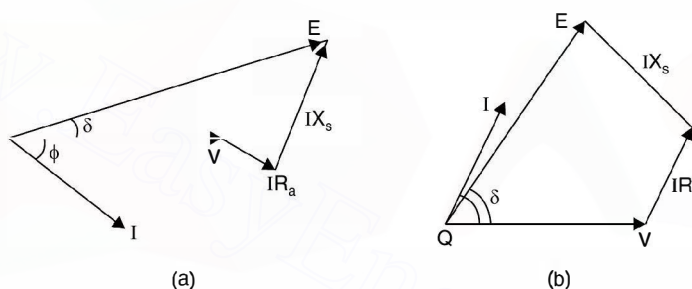

Fig. 7.9. Phasor diagram for an alternator (a) lag p.f. (b) lead p.f.

Here V is the terminal voltage under load condition and E is the induced voltage or the terminal voltage when the load is zero. $\cos \phi$ the p.f. of the load and δ is the angle between E and V and is known as torque angle or power angle or load angle.

From the phasor diagram

$$E = V + IR_a + jIX_s$$

where E , V and I are phasor quantities. From here usually V , I , $\cos \phi$, R_a and X_s are known, the magnitude of E can be obtained and hence voltage regulation can be obtained. However, if approximate value of voltage regulation is required the following expression can be used as is done in case of a transformer.

Approximate voltage regulation

$$= \frac{IR_a}{V} \cos \phi \pm \frac{IX_s}{V} \sin \phi.$$

7.2.6 Losses and Efficiency

Normally we define efficiency of a machine as the ratio of output to its input. For a generator it is usually convenient to define efficiency as

$$\frac{\text{Output}}{\text{Output} + \text{losses}}$$

It is due to the fact that even when all facilities of measurement are available it is difficult to measure mechanical power input to the alternator.

The losses directly chargeable to a synchronous generator include

1. I^2R loss in (a) armature winding (b) in field winding (c) at the contact between brushes and slip rings.
2. Core loss.
3. Friction and windage loss including the loss due to circulation of air through a closed ventilating system and also the brush friction loss at the slip rings.
4. The stray load loss caused by eddy currents in the armature conductors and by additional core loss due to the distortion of the magnetic field under load conditions.

The I^2R losses in the armature and field windings are computed by using the dc value of resistance corrected to the working temperature of 75°C .

The core loss including hysteresis and eddy current losses, is that which corresponds to zero main flux at rated frequency when the machine develops an open circuit (no load) voltage per phase equal to the phasor sum of its rated voltage per phase and the ohmic drop per phase.

7.2.7 Magnetic Poles in Machines

The torque developed by electrical machines is the result of attraction and repulsion between magnetic poles on the rotor and stator. We know that magnetic poles of like polarity repel each other whereas magnetic poles of unlike polarity attract each other. In machines, the windings are so designed that they develop magnetic poles on the inside surface of the stator and the outside surface of the rotor. In other words, these poles appear on the inner and outer surfaces of the air gap. Repulsion and attraction between the rotor poles and those of the stator produce a torque on the rotor and a reaction torque against the stator.

To produce a unidirectional and continuous torque, the no. of rotor poles must equal the number of stator poles. The no. of poles on either the rotor or the stator must be even. If a machine has four stator poles, there must be four rotor poles and the machine is said to have four poles. If the machine is in the motor mode, the torque on the rotor causes it to rotate.

Since the rotor poles have constant polarity, their windings must be supplied with direct current. This current may be provided by an external dc generator or by a rectifier. In this case the leads from the field winding are connected to insulated rings mounted concentrically on the shaft. Stationary contacts called brushes ride on these slip rings to carry current to the rotating field windings from the dc supply. The brushes are made of a carbon compound to provide a good contact with low mechanical friction. An external d.c. generator used to provide field current is called an exciter.

7.2.8 Steady State Operation

As mentioned earlier the synchronous motor as such is not self-starting. This is explained as follows : Suppose we feed dc supply to the field winding on the rotor through an exciter. As a result north and south poles are set up on the rotor. These north and south poles are stationary in space. If we feed three-phase supply to the stator winding, this gives rise to a rotating magnetic field of constant magnitude and rotating at synchronous speed. The north and south poles of the stator magnetic field are rotating at synchronous speed. Suppose at the instant of switching, the north

pole of stator coincides with the south pole axis of the rotor. The tendency of the rotor pole will be to get attracted and start rotating along the stator magnetic field. But since the rotor has certain inertia and by the time the rotor tries to go along the stator magnetic field the south pole of the stator magnetic field coincides with the same south pole of the rotor and the rotor is repulsed. The variation is so fast that the rotor is not able to respond to the instantaneous variation of the stator magnetic field and the rotor thus is not able to start rotation and it is a non self-starting machine.

7.2.9 Power and Torque

Using the equivalent circuit in Fig. 7.10 of the synchronous motor we derive expressions for power and torque. Since we are considering the motor circuit, electric power is being fed into the motor and the mechanical power is available at the shaft of the motor.

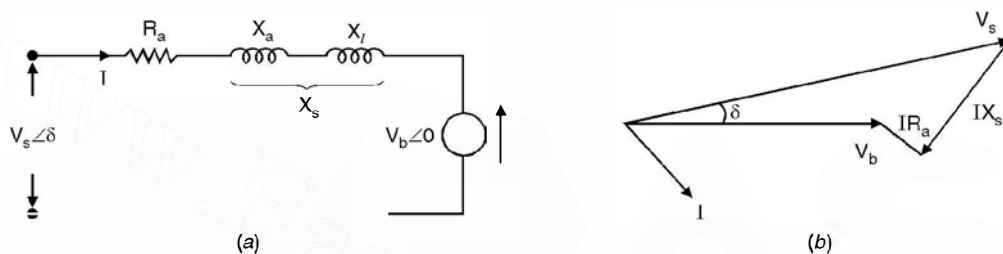

Fig. 7.10. (a) Equivalent circuit of the synchronous motor.
(b) Phasor diagram of (a).

In Fig. 7.10, R_a is the armature resistance per phase, X_l is the leakage reactance between the stator and rotor magnetic field and X_a is the equivalent corresponding to armature reaction. The sum total of the X_a and X_l is represented as X_s and is known as synchronous reactance. Assuming losses in the synchronous motor to be negligibly small when the motor is running under no load condition, the stator magnetic field axis coincides with the rotor magnetic field axis. However if some load is added to the shaft of the motor, under steady state operating condition, the rotor magnetic field axis falls back from the stator magnetic field axis by an angle δ known as torque angle or load angle. Obviously, this angle will be decided by the load added to the shaft. In Fig. 7.10 (b), V_s is shown to be leading V_b by an angle δ which is the torque angle. Here V_b the counter emf is taken as reference and V_s is the supply per phase voltage leading V_b by an angle δ . In fact this angle is an indicator of power flow from supply terminals to motor terminals. Power will always flow from leading voltage towards lagging voltage. The current I

$$I = \frac{V_s \angle \delta - V_b \angle 0}{j X_s} = \frac{V_s \angle \delta - 90 - V_b \angle -90}{X_s} \quad \dots(7.12)$$

neglecting resistance of the armature winding.

$$\begin{aligned} \text{Now, Power } P &= R_e [V_b I^*] \\ &= R_e \left[V_b \frac{V_s \angle 90 - \delta - V_b \angle 90}{X_s} \right] \\ &= \left[\frac{V_b V_s \cos (90 - \delta)}{X_s} - V_b^2 \cos 90^\circ \right] \end{aligned}$$

$$= \frac{V_b V_s}{X_s} \sin \delta \quad \dots(7.13)$$

$$Q = I_m \left[V_b \frac{V_s \angle 90 - \delta - V_b \angle 90}{X_s} \right]$$

$$= \frac{V_b V_s}{X_s} \cos \delta - \frac{V_b^2}{X_s} \quad \dots(7.14)$$

A plot of equation 7.13 is shown in Fig. 7.11. Assuming $|V_s|$ and $|V_b|$ to remain constant, one important conclusion is drawn.

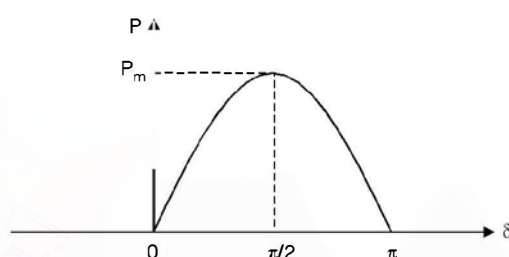

Fig. 7.11. Power angle curve for a motor connected to the supply system.

There is a definite upper limit to the power flow to the motor from the source and is equal to

$$P_m = \frac{|V_s| |V_b|}{X} \quad \dots(7.15)$$

When $\delta = 90^\circ$ i.e. the rotor magnetic axis falls back the stator magnetic axis by 90 electrical degree. In fact, if an attempt to load the motor more than this power is made, the south pole of the rotor magnetic field falls in the region of south pole of the stator magnetic field and there will be repulsion and the rotor will fall out of step from the stator magnetic field and the rotor comes to a stop. This is also known as pull out power of the motor

$$\text{Now} \quad P = 2\pi N T$$

$$\text{or} \quad T = \frac{P}{2\pi N}$$

Since synchronous motor, under steady state conditions either runs at synchronous speed or does not run at all. Hence $N = n_s$

$$\text{and} \quad T = \frac{|V_b| |V_s|}{X_s} \sin \delta \cdot \frac{1}{2\pi n_s} \quad \dots(7.16)$$

where n_s is the synchronous speed in rps

From phasor diagram of Fig. 7.10 (b) we can write

$$V_s = V_b + I(R_a + jX_s)$$

i.e. the supply voltage equals phasor sum of the counter emf and the drop across the synchronous impedance. The drop is normally negligible as compared to $|V_s|$ or $|V_b|$ and hence $|V_s|$ and $|V_b|$ are practically equal to each other. We make use of the observation and study the effect of excitation on the armature current.

7.3 EFFECT OF EXCITATION ON ARMATURE CURRENT

We know that a synchronous motor is fed dc supply to the rotor and 3-phase ac to the stator. The rotor field winding gives rise to magnetic field in the air gap and induces voltage in the stator winding. However, the supply from the stator winding induces voltage in the stator conductor (counter emf) and the resultant of the supply voltage and the counter emf circulates current in the stator winding. These currents give rise to magnetic flux in the air gap which either demagnetises the flux due to dc rotor winding or cross-magnetises it depending upon whether the current in the stator is a leading current or lagging current respectively with respect to supply voltage. In fact, it is the net flux (flux due to dc field and due to armature current) which decides the counter emf in the stator winding.

Now the counter emf is proportional to the speed and to the field flux, and since the speed of the motor is constant at synchronous speed, the field flux likewise be substantially constant within the normal limits of operation. It follows then that if the field excitation is increased, the flux due to field current increases in the air gap. In order for the net flux in the air gap to remain constant, the current change in the stator conductor be such as to nullify the change (increase) in flux. This means the stator must draw leading component of current as the leading component of current in armature demagnetises the flux in the air gap *i.e.* with this increase in excitation if the armature current earlier was lagging with some p.f., now it will be less lagging and hence higher p.f. Similarly, if the field excitation is decreased which decreases flux in the air gap, the armature will draw additional component of lagging current to strengthen the field in the air gap. For any set of operating conditions, there will be some value of field excitation which will cause the p.f. to be unity *i.e.* the current to be in phase with the terminal voltage. When this condition exists while the motor is carrying its rated load, the motor is said to have normal excitation. Assuming losses to be negligible, for certain power input or output, it can be demonstrated that by varying excitation of the field of the motor, the current will vary from lagging p.f. to leading p.f. as shown in Fig. 7.12 and this is known as 'V' curve of the synchronous motor.

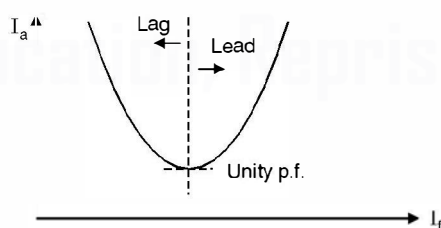

Fig. 7.12. 'V' curve for the synchronous motor.

When synchronous motor is used exclusively for drawing leading current from the system (or supplying lagging current to the system) to compensate for the other inductive loads, the motor is known as synchronous condenser. It can, therefore, be seen that a synchronous motor is a very good neighbour. It can be used to correct a lagging p.f. and it helps keep line voltages constant and balanced. It helps keep line voltages constant because it can draw lagging and leading current by changing excitation suitably.

If the terminal voltages supplied to a synchronous motor are unbalanced, the air gap flux will vary as it passes the different phase groups. The damper winding (about this winding we will discuss a little later) will have according to Lenz's law currents flowing in them which will tend to make flux constant. This improves the voltage balance.

7.4 CHANGE OF LOAD

Suppose a synchronous motor is connected to the grid and is carrying certain load and the load angle or torque angle is δ_0 . Now, let us add some more load to the shaft of the motor. Suppose corresponding to this load the load angle under steady state operating condition is δ_1 . The motor does not come to this angle δ_1 instantly because of inertia of the rotor. In fact while falling further back from the stator magnetic axis from δ_0 to δ_1 , it overshoots and keeps on oscillating around its new position δ_1 as shown in Fig. 7.13.

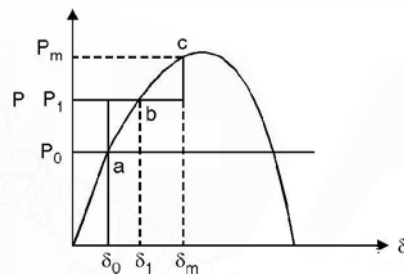

Fig. 7.13. Increase of load.

When the rotor moves in its forward journey from a to c the speed is less than the synchronous speed. At a and c the speed equals the synchronous speed. Between a to b the speed is decreasing and is less than synchronous speed and is minimum at b . Between b and c the speed increases but is still less than synchronous speed. During its return journey from c to a , the speed is more than synchronous speed. Between c and b the speed increases and is above the synchronous speed. At b , during return journey the speed is maximum and more than synchronous speed. Between b and a , the speed decreases but is more than the synchronous speed. At a the speed is again the synchronous speed. Finally, of course, the motor will settle at b corresponding to δ_1 after the oscillations are damped out.

7.5 STARTING OF SYNCHRONOUS MOTOR

We know that a synchronous motor is not-self starting. Some additional devices should be used to start the motor. Basically there are two methods :

1. Induction motor starting (Damper winding)
2. Auxiliary motor starting.

7.5.1 Damper Winding Starting

Most of the synchronous motors have salient pole structure. As mentioned earlier a winding consisting of heavy copper bars is installed in slots in the pole faces. These bars are all shorted together at both ends of the rotor. When 3-phase supply is fed to the stator, a rotating magnetic

field is produced in the air gap which induces currents in the bars which further produces flux. The interaction of the fluxes produces torque in the direction of field rotation. In other words, the motor is started as an induction motor, the bars in the pole face slots forming a sort of squirrel cage rotor. Induction motor action will bring the motor to nearly synchronous speed. At synchronous speed there is no relative motion between the poles of the air gap field and the pole face bars. No current is induced in the bars at synchronous speed, and no torque would be produced by them. However, the maximum speed developed on induction motor action is very close to synchronous speed and the rotor falls into step when the dc field current is switched on.

The field winding terminals are usually shorted through a resistor during starting until such time that the field is excited. This has two advantages. First it protects the slip ring insulation from the high ac voltage induced in the field during starting. Second the current circulating in the field winding would provide a small additional accelerating torque.

The heavy bar winding in the pole faces serve an additional purpose. As mentioned in the previous article that when there is sudden change of load the load angle δ changes to adjust to the new load requirement. The magnetic attraction between the air gap flux and the rotor mmf poles has a springlike quality and the rotor has considerable inertia. As a result there is an oscillatory motion of the rotor superimposed over the normal synchronous rotation of the shaft. This relative motion is called hunting. The relative speed between the air gap flux and the bars induces currents in these bars. The field set up by these currents produces a torque that opposes any change in δ and the angular oscillation is damped out fast. For this reason the pole face bars are called damper bars and the winding consisting of these heavy bars and their end connections is called the damper winding or by their French name, the amortisseur winding (Roughly translated this means "killer winding"). Because of high degree of hunting present in these machines, the damper windings are installed in nearly all synchronous machines, generators as well as motors having salient poles. Cylindrical rotor cores cannot be laminated and still maintain the required mechanical strength. Eddy currents, therefore, can circulate freely in the pole faces. Since the flux through the pole faces remains constant under steady state condition, these eddy currents are induced only during transients (*e.g.* during change of load). The interaction of the eddy currents with the air gap flux provides the necessary damping action in cylindrical rotor synchronous machines.

7.5.2 Auxiliary Motor Starting

The auxiliary motor may be a dc shunt motor or an induction motor having the same no. of poles as the synchronous motor or two poles less as compared to synchronous motor. The job of the auxiliary motor is to bring the synchronous motor to synchronous speed or near synchronous speed. The auxiliary motor is mechanically coupled to the synchronous motor. No load is put on the synchronous motor during starting. Therefore, the auxiliary motor has to overcome only the inertia of the synchronous motor and may have its rating much smaller than that of the synchronous motor being started.

When the speed is near synchronous speed, the 3-phase supply is switched on to the armature and dc supply to the field circuit of synchronous motor. The synchronous motor pulls into step, its speed rises to synchronous speed and it continues to run at this speed.

If the induction motor has two poles less than synchronous motor, the induction motor speed is higher than the synchronous speed of the synchronous motor. Once the higher speed is

attained, the supply to induction motor is switched off and 3-phase supply to synchronous motor is switched on. When the speed of the synchronous motor almost equals the synchronous speed, it's field winding is energized. The synchronous motor pulls into step and starts running at synchronous speed. However, in modern days this method of starting is hardly used. It is mainly the damper winding which is utilised for starting the synchronous motor.

7.6 SPEED TORQUE CHARACTERISTIC

A synchronous motor runs at a constant speed, known as synchronous speed and depends upon the no. of poles and frequency of supply. It is usually connected to a large system also known as an infinite bus which has constant voltage and frequency. The torque equation (7.4) is rewritten here

$$T = \frac{|V_b| |V_s|}{X_s} \sin \delta \cdot \frac{1}{2\pi n_s}$$

The speed torque characteristic of synchronous motor is shown in Fig. 7.14.

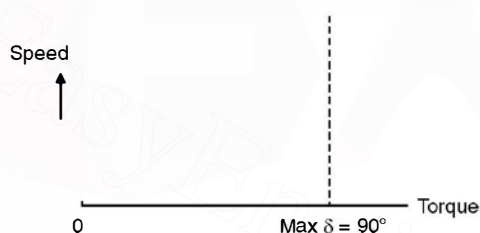

Fig. 7.14. Speed torque characteristic of a synchronous motor.

The speed remains constant from no load to the maximum load (pull out load) which occurs at $\delta = 90^\circ$. The full load torque is normally 50% ($\delta = 30^\circ$) of the pull out torque ($\delta = 90^\circ$).

As explain earlier when the load on the motor is more than the pull out load ($\delta = 90^\circ$) the north of the rotor comes against the north pole of the stator magnetic field and they repel each other which finally results into the motor losing synchronism with the supply system and the motor comes to a stop.

7.7 SYNCHRONOUS CONDENSER

As mentioned earlier when a synchronous motor is overexcited it acts as a synchronous condenser. Of course there is an upper limit for excitation due to heating of the field winding. The special feature of the motor when used as synchronous condenser is that it is run under no load condition, thereby $\delta = 0$ and the induced emf due to excitation is greater than the supply voltage *i.e.*, reactive power Q can be continuously and simply controlled by controlling induced emf by varying the excitation. However, if the synchronous motor is used over the complete range of excitation as shown in Fig. 7.12, the machine is then known as synchronous phase modifier.

A synchronous phase modifier has a smaller shaft (as no mechanical load is to be connected) and bearing and higher speeds as compared to a synchronous motor used for mechanical loads. A synchronous phase modifier has a higher overall efficiency as compared to a synchronous motor.

A great advantage of the synchronous capacitor is its flexibility for use for all load conditions because it supplies reactive power when overexcited *i.e.* during peak load conditions when the system voltage is likely to go down below acceptable limits if p.f. correcting measures are not adopted, and it consumes reactive power when underexcited during light load conditions. During light load condition the system voltage may go up, more than the accepted value due to Ferranti effect. Here the phase modifier may be under excited thereby absorbing the reactive power and maintaining the system voltage within permissible limits. There is smooth variation of reactive power by synchronous capacitor as compared with step by step variation by the static capacitors.

Synchronous motors can be overloaded for short periods whereas static capacitors cannot. For large outputs the synchronous capacitors are much better than the static capacitors from economic point of view because otherwise a combination of shunt capacitors and reactors is required which becomes costlier and also the control is not smooth as is achieved with synchronous capacitors.

The main disadvantage of the synchronous capacitor is the possibility of its falling out of step which will thus produce a large sudden change in voltage. Also, these machines add to the short-circuit capacity of the system during fault condition.

An important statement is made about the synchronous machines.

A synchronous machine (irrespective of whether it is a generator or a motor) delivers lagging reactive power to the system when overexcited and it draws lagging reactive power from the system when underexcited.

To understand this statement we take up a very simple illustration shown in Fig. 7.15.

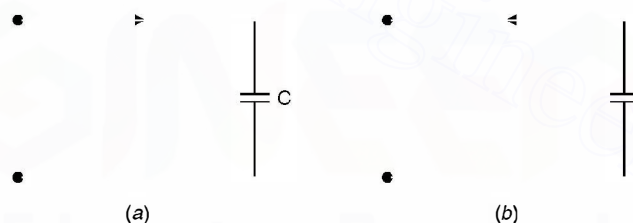

Fig. 7.15. Capacitor connected to supply.

In Fig. 7.15 (a) the capacitor is taking leading current and that is what actually is, as it is acting a sort of load. However, if we consider capacitor a source of reactive power, Fig. 7.15 (b) is appropriate and Fig. 7.15 (b) means the capacitor is supplying lagging reactive power to the source. Therefore, if a load takes leading current it is equivalent to saying that it is supplying lagging current.

Similarly synchronous motor is a load and when it is overexcited, it operates at leading p.f. *i.e.* it takes leading reactive power from the source which is equivalent to saying that it is supplying lagging reactive power to the system. For a generator which generates and feeds to the system, operates at lagging p.f. and hence it delivers lagging reactive power to the system when overexcited. Similarly, it can be justified that if the synchronous machine is underexcited it takes lagging reactive power from the system.

7.8 APPLICATIONS

Synchronous motors have many advantages when a constant speed is desirable. Typical applications are to drive pumps, fans, and dc generators. They can be operated at unity p.f., thus minimising the line current. In sizes above 2000 hp synchronous motor's cost less than induction motors having static capacitors for p.f. correction. A major advantage of synchronous motors is that it can be used as a phase modifier and hence it can take care of the overloading and no load voltage variations by overexciting and underexciting its field winding respectively. During overexcitation it draws leading current and thus corrects the overall p.f. of a plant having other equipment drawing lagging current.

Example 7.1. A 2300 V, 3-phase synchronous motor driving a pump is provided with a line ammeter and a field rheostat. When the rheostat is adjusted so that the ac line current is a minimum, the ammeter reads 8.8 A. What approximate power is being delivered to the pump? How should the rheostat be adjusted so that the motor is operating at 0.8 pf lead? How many KVARs is the motor supplying to the system at 0.8 p.f. lead?

Solution. From the 'V' curve we know that for a given power, the current is minimum at unity p.f. Hence power drawn from the line is

$$P = \sqrt{3} V_L I_L = \sqrt{3} \cdot 2300 \cdot 8.8 = 35 \text{ kW}$$

In order to obtain 0.8 lead p.f., the excitation current should be increased *i.e.* the field rheostat resistance should be decreased such that the armature current I is given as

$$\sqrt{3} V_L I \cos \phi = 35000$$

or
$$I = \frac{35000}{\sqrt{3} \times 2300 \times 0.8} = 10.98 \text{ A} \approx 11 \text{ Amp.}$$

The kVAR supplied by the motor

$$\begin{aligned} \sqrt{3} VI \sin \phi &= \sqrt{3} \times 2300 \times 11 \times 0.8 \\ &= 26.29 \text{ kVAR. } \quad \text{Ans.} \end{aligned}$$

Example 7.2. A manufacturing plant presents an electrical load to the power system, of 5000 kW at 0.8 p.f. lag. It has been decided to replace a 500 hp induction motor that drives a pump. The motor operates at an efficiency of 96% and a p.f. of 0.9 lag. If a synchronous motor is purchased as a replacement, which is capable of operating at 0.8 p.f. lead. What will be the new plant p.f.? Assume the synchronous motor to have the same efficiency. What per cent decrease in line current will result from the improved p.f.

Solution.

$$\begin{aligned} \text{Original power (complex)} &= 5000 + j 5000 \tan \cos^{-1} 0.8 \\ &= 5000 + j 5000 \times \frac{6}{8} = 5000 + j 3750 \text{ kW} \end{aligned}$$

The power input to induction motor

$$\frac{500 \times 735}{0.96} = 382.8 \text{ kW}$$

Hence complex power of induction motor

$$382.8 + j 382.8 \tan \cos^{-1} 0.9$$

$$= 382.8 + j 382.8 \frac{0.436}{0.9}$$

$$= 382.8 + j 185.4 \text{ kVA}$$

Complex power of the synchronous motor

$$382.8 - j 382.8 \times \frac{0.6}{0.8}$$

$$= 382.8 - j 287.1 \text{ kVA}$$

Now plant requirement

$$5000 + j 3750 - 382.8 - j 185.4 + 382.8 - j 287.1$$

$$= 5000 + j 3277.5 \text{ kVA} = 5978 \text{ kVA}$$

Now p.f. $\cos \tan^{-1} \frac{3277.5}{5000} = 0.836$

Original current $= \frac{5000 \times 1000}{\sqrt{3} V_L \times 0.8} = \frac{6250}{\sqrt{3} V_L}$

New current $= \frac{5978 \times 1000}{\sqrt{3} V_L}$

Hence percentage reduction $\frac{6250 - 5978}{6250} \times 100$
 $= 4.3\%.$ **Ans.**

Example 7.3. In the plant of example 7.2, what should be the kVA rating of a synchronous condenser to correct the original p.f. to 0.9.

Solution. The original complex power of the plant is $5000 + j 3750$

At 0.9 p.f. the plant Q would be

$$5000 \tan \cos^{-1} 0.9 = 5000 \times \frac{0.436}{0.9}$$

$$= 2422 \text{ kVAr}$$

The difference must be supplied by the synchronous condenser

$$3750 - 2422 = 1328 \text{ kVAr. Ans.}$$

Example 7.4. A 2300 V, 3-phase star connected synchronous motor has synchronous reactance of 10 ohm per phase. When motor delivers 255 hp the efficiency is 90%. The power angle is 20° . Calculate (a) E per phase (b) I (c) p.f. Neglect resistance.

Solution. Neglecting resistance the power expression is

$$P = \frac{3EV}{X_s} \sin \delta$$

Now power input to the motor is $\frac{255 \times 735.5}{0.9}$

Hence $3E \times \frac{2300}{\sqrt{3}} \cdot \frac{1}{10} \sin 20^\circ = \frac{255 \times 735.5}{0.9}$

$$136 E = 208391$$

or

$$E = 1532 \text{ volts per phase}$$

$$\begin{aligned}\text{Current } I &= \frac{1328 \angle 0 - 1532 \angle -20}{j 10} = \frac{1328 - 1439 + j 524}{j 10} \\ &= \frac{-111 + j 524}{j 10} = j 11.1 + 52.4 \\ \phi &= 11.9^\circ\end{aligned}$$

Hence p.f. 0.98 lead. **Ans.**

Example 7.5. Determine the voltage regulation of a 3-phase 1500 kVA, 6.6 kV alternator at (i) 0.8 lag and (ii) 0.8 lead p.f. if the resistance and reactance of the alternator are 0.093 ohm and 8.5 ohm respectively.

Solution. Per phase terminal voltage

$$\frac{6600}{\sqrt{3}} = 3810.5 \text{ Volts}$$

$$\text{Full load current} = \frac{1500}{\sqrt{3} \times 6.6} = 131.2 \text{ A}$$

(i) 0.8 lag

Taking voltage as reference current

$$\begin{aligned}I &= 131.2(0.8 - j0.6) \\ &= 104.96 - j78.72\end{aligned}$$

Hence the drop

$$\begin{aligned}I(R_a + jX_s) &= (104.96 - j78.72)(0.093 + j8.5) \\ &= 9.76 + j892.6 - j7.32 + 669.12 \\ &= 678.9 + j885.28\end{aligned}$$

$$\begin{aligned}\text{Hence } E &= 3810.5 + 678.9 + j885.28 \\ &= 4489.4 + j885.28 \\ &= 4575 \text{ Volts.}\end{aligned}$$

Hence regulation

$$\frac{4575 - 3810}{3810} \times 100 \simeq 20\%$$

However, if we follow approximate expression for voltage regulation

$$\begin{aligned}\frac{IR}{V} \cos \phi + \frac{IX_s}{V} \sin \phi \\ \frac{131.2 \times 0.093 \times 0.8 + 131.2 \times 8.5 \times 0.6}{3810}\end{aligned}$$

$$\% \text{ regulation} = \frac{9.76 + 669.12}{3810} \times 100 \simeq 17.8\%$$

(ii) 0.8 lead p.f.

$$\text{The current} \quad 131.2(0.8 + j0.6) = 104.96 + j78.72$$

The drop IZ_s

$$(104.96 + j78.72)(0.093 + j8.5) \\ 9.76 + j892.6 + j7.32 - 669.12 - 659.36 + j899.92$$

Hence $E = 3810 - 659.36 + j899.92 = 3150.64 + j899.92$
 $E = 3276$ Volts

Hence % regulation $= \frac{3276 - 3810}{3810} \times 100$
 $= -14\%$. **Ans.**

However by using approximate expression

Voltage regulation $= \frac{9.76 - 669.12}{3810} \times 100$
 $\approx -17\%$. **Ans.**

Example 7.6. If a field excitation of 10 A in a certain alternator gives a current of 150 A on short circuit and a terminal voltage of 900 V on open circuit, find the internal voltage drop with a load current of 60 A.

Solution. By definition synchronous impedance

$$= \frac{\text{Open circuit voltage for certain } I_f}{\text{S.C. current for same } I_f}$$

$$Z_s = \frac{900}{150} = 6 \Omega$$

The internal voltage drop

$$= IZ_s = 60 \times 6 \\ = 360 \text{ Volts. } \mathbf{Ans.}$$

7.9 STEPPER MOTOR

A stepper motor is a polyphase synchronous motor having salient stator poles. The name *stepper* derives from the most common application for these machines *i.e.* rotating a fixed angular step in response to each input pulse received by their controller when this type of motor is fed from an electronic drive, accurate position control and precise rotational speeds are obviously obtained.

Based on principle of operation, stepper motors may be divided into three categories. These are, permanent magnet, variable reluctance and hybrid type which utilize both principle for torque development. Fig. 7.16 shows the three rotor types and their respective torque/displacement characteristics.

7.9.1 Permanent Magnet Type

Consider the simplified two-phase stator with two-pole permanent magnet rotor shown in Fig. 7.17. The rotor is shown in a stable equilibrium position for the case when $i_1 > 0$ and $i_2 = 0$. Stepping action is produced by switching current i_1 and i_2 , supplied from a bipolar source. Three possible sequences for producing clockwise rotation are given. The first energises only one phase winding

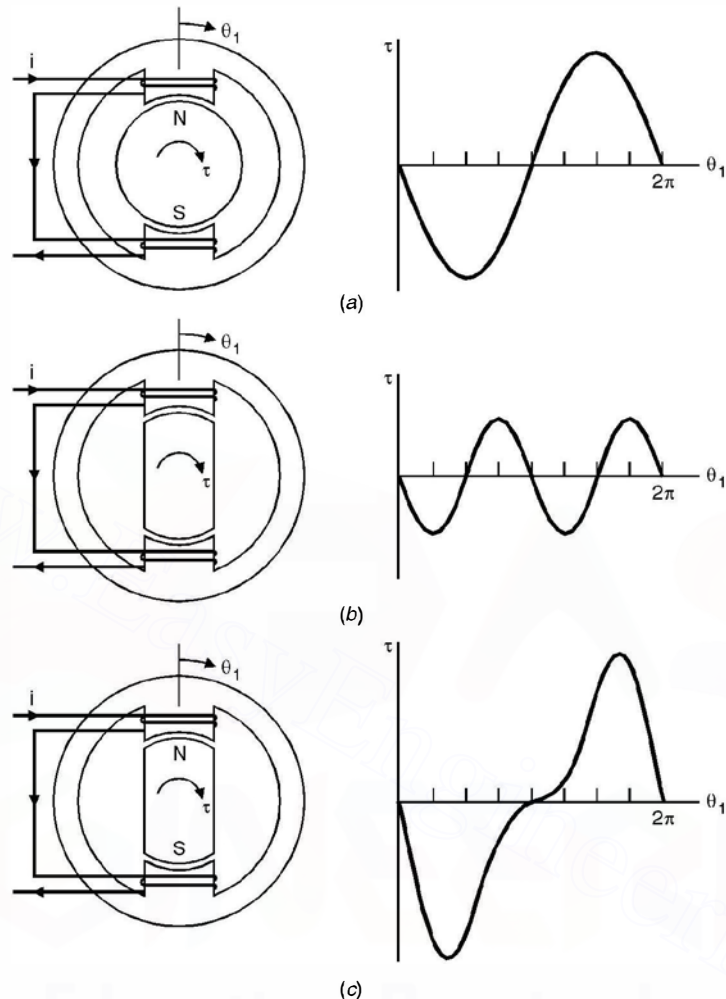

Fig. 7.16. Torque development in the three basic types of stepper motors.
 (a) Permanent-magnet rotor. (b) Variable reluctance rotor. (c) Hybrid rotor.

at a time. The resulting step size is one-half the pole pitch. The second method energises both simultaneously and would thus require larger power supply. The resulting steps are the same size, but the effective stator pole positions are located midway between the pole pieces. Advantages of this scheme are increased torque and damping. The final method, known as half-stepping, alternates between one and two phases. The resulting step size is one-fourth the pole.

Various techniques have been used to produce smaller step sizes. Perhaps the most obvious is to increase the number of poles or the number of phases or both.

Both permanent magnet and variable reluctance rotor can be used. However, a permanent magnet motor provides smooth response.

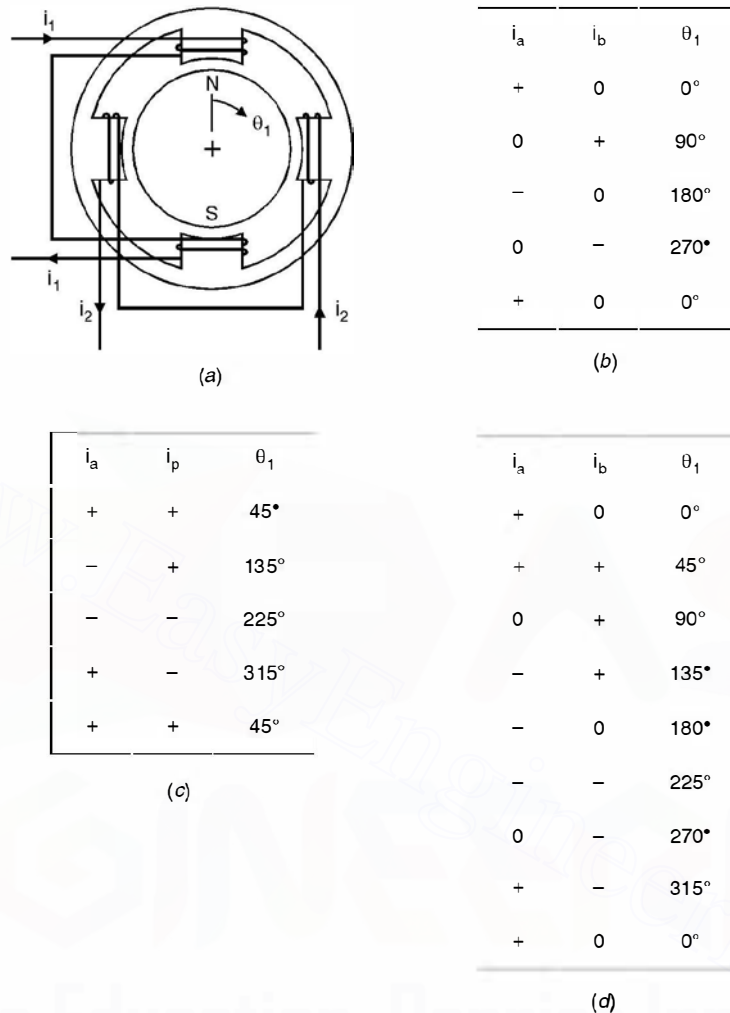

Fig. 7.17. Two-phase permanent-magnet stepper motor. (a) Cross-section (b) Full-step, single-winding sequence. (c) Full-step, two-winding sequence. (d) Half-step sequence.

An identical torque/speed characteristic for a stepper motor is shown in Fig. 7.18. Note that two modes of operations are possible. The normal mode could be called *locked step*. In this mode the combined load plus the rotor inertia is less than the developed torque, with the result that the rotor may come to rest (or at least experience a reversal of momentum) between steps. Starts, stops and instantaneous reversals are possible. The second mode called *slewing* maintains synchronism but does not permit stops or reversals. Some applications utilise both modes e.g. a magnetic tape drive may read/write at a step rate in the normal mode but rewind/fast forward in the slewing mode. The transition to and from slewing must be properly controlled to avoid loss of synchronism.

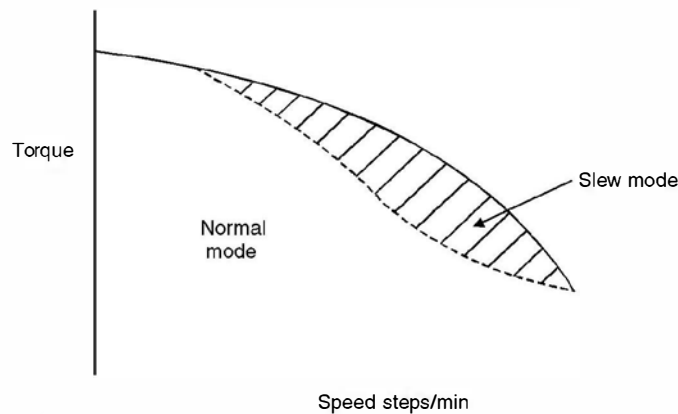

Fig. 7.18. Typical speed-torque characteristic of stepper motor.

7.9.2 Comparison of Stepper Motors

Stepper motors are available with step sizes ranging from 90° to 0.72° . Maximum step rates vary from about 100 to as many as 10,000 per sec. Torque capacities vary over a wide range. Selection of a stepper motor for a particular application must consider the overall performance of the motor with electronic drive.

Permanent magnet steppers are available in the larger step sizes, usually about 5° . They exhibit excellent torque/volume ratios but typically have high inertia rotors. The rotor provides braking and holding torque even with the stator windings deenergised. The variable reluctance motor is ideally suited to the smaller step sizes. By comparison, it develops less torque. However, since it may be constructed with a low inertia rotor, its torque/inertia ratio may be superior. The rotor is capable of “free-wheeling” since braking and detent torque must be provided by the stator. The hybrid stepper combines the smaller step size of the variable reluctance rotor with the higher torque of the permanent magnet. Some braking and holding torque is also present. As might be expected, it is the most expensive of the three types to manufacture.

7.9.3 Application

The characteristics of stepper motors make them ideally suited to many applications requiring incremental motion, especially where digital control is used. A few common ones are printer head and paper feed drives in computer printers, disc drives, digital plotters, medical equipment that dispenses precise dosages, computer controlled tools and process control valves.

PROBLEMS

- 7.1. Explain why a synchronous motor is not self-starting.
- 7.2. What is a damper winding ? Explain its application for a synchronous motor.
- 7.3. Describe briefly the construction, principle of operation and application of a synchronous motor.
- 7.4. Explain why a synchronous motor develops torque at synchronous speed whereas an induction motor develops torque at all speeds except the synchronous speed.

- 7.5. Derive expressions for active power and reactive power input to a synchronous motor when connected to a large system. Neglect resistance.
- 7.6. What is a synchronous condenser ? Explain its operation for improvement of power factor of the electric installation.
- 7.7. What is synchronous phase modifier ? Explain its operation.
- 7.8. Explain the operation of a synchronous motor when a change in load on the motor takes place.
- 7.9. Explain different methods of starting a synchronous motor.
- 7.10. A synchronous motor overexcited to take 600 kVA gives 360 hp at an efficiency of 0.9. It runs in parallel with a load of 1000 kVA at p.f. 0.8 lag. Find the resultant power factor.
[Ans. (0.99) lag]
- 7.11. Name different types of stepper motors and explain the construction and operation of permanent magnet type stepper motor.
- 7.12. Draw and explain a typical torque/speed characteristic of a stepper motor and compare the performance of the three types of motors.
- 7.13. A 1500 kVA, 6600 V, 3-phase star connected alternator has a resistance of 0.4Ω and reactance of 6Ω per phase and delivers full load current at p.f. 0.8 lag and normal rated voltage. Determine the terminal voltage for the same excitation and load current at 0.8 p.f. lead. [Ans. 8220 V]
- 7.14. A 3-phase star connected alternator is rated at 1600 kVA 13.5 kV. The armature effective resistance and synchronous reactance are 1.5Ω and 30Ω respectively per phase. Calculate the percentage regulation for a load of 128 kW at p.f. of (i) 0.8 lead (ii) unity (iii) 0.8 lag.
Ans. [(i) – 11.8% (ii) 3.2% (iii) 18.6%]
- 7.15. Define voltage regulation of a synchronous generator. Discuss the conditions under which voltage regulation could even be negative.
- 7.16. Explain with neat diagram OC and SC test on a 3-phase alternator and describe the procedure to obtain synchronous impedance of the alternator using these tests.
- 7.17. Discuss in brief the constructional features of cylindrical rotor and salient pole alternator.
- 7.18. What is pitch factor ? Is it always less than one ? Derive an expression for the pitch factor of a winding using coil short pitched by angle ρ .
- 7.19. Explain what you mean by armature reaction in an alternator. Explain the effect of armature reaction when the power factor of stator currents is (a) unity (b) lagging (c) leading.
- 7.20. Starting from first principle derive emf equation of a 3-phase alternator.
- 7.21. Show graphically that the currents in the stator winding of a 3-phase alternator give rise to magnetic field which has a constant magnitude and rotates in space at a constant speed.
- 7.22. Show analytically that the current in the stator winding of a 3-phase alternator gives rise to magnetic field of constant magnitude and rotates in space at a constant speed.

CHAPTER

8

Three-Phase Induction Motors

8.1 INTRODUCTION

The three-phase induction motor is the most commonly used motor in any power system. It forms about 50 to 70% of the total load in the system. Ordinarily, it is more or less a constant speed motor and thus has a disadvantage as compared to d.c. motors. However, with the advent of thyristorised control, using variable voltage variable frequency control, induction motors which are inherently simple in construction and robust, have replaced the d.c. series motors used for traction purposes.

8.2 CONSTRUCTION

In the most commonly form a polyphase induction motor consists essentially of a stator and a rotor. The stator supports windings which receive energy from the source and the rotor carries windings in which the working current is induced.

The core of stator is laminated and is made of sheet steel punchings and is slotted in its inner cylindrical surface and the winding consists of embedded coils disposed in exactly the same manner as those of a revolving field synchronous generator for the same number of poles. In motors of large ratings, the stator slots are of the open type *i.e.*, the side walls of the slots are parallel to facilitate the insertion of form-wound coils which are completely insulated before they are slipped into place ; but in smaller size motors, the slots are partially closed in order to reduce the effective length of the air gap between stator and rotor.

For small and medium size motors the entire cage winding, bars and end rings together is made of aluminium cast in place as an integral unit. This construction has the advantage of economy in manufacture.

Basically there are two types of poly phase induction motors (*i*) squirrel cage rotor type (*ii*) slip ring induction type. The difference in the two types is because of difference in construction of rotor, the stator design is same in both the cases.

The squirrel cage rotor has winding consisting of conducting copper or aluminium bars in slots in the rotor iron and short-circuited at each end by conducting end rings. The extreme simplicity and ruggedness of the squirrel cage construction are outstanding advantages of this induction motor. Thus the rotor in case of squirrel cage construction acts as the short-circuited secondary of a transformer of which the stator acts as the primary winding.

The slip ring rotor or the wound rotor carries a polyphase winding similar to and wound for the same number of poles as the stator. The terminals of the rotor winding are connected to insulated slip rings mounted on the shaft. Carbon brushes, bearing on these rings make the rotor terminals available external to the motor. The terminals of the rotor winding are brought out through slip ring to a suitably controlled and balanced rheostat.

8.3 PRINCIPLE OF OPERATION

When a 3-phase supply is connected to the stator terminals (normally delta connected as per the same voltage the torque developed is higher as compared to when it is star connected as

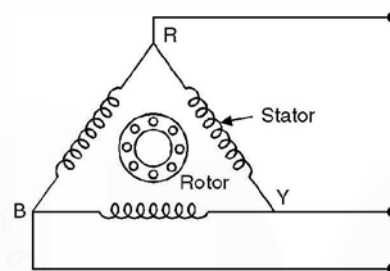

Fig. 8.1. Schematic diagram of squirrel cage motor.

voltage per phase is line voltage in delta connection) of the squirrel cage motor, the currents in the stator winding give rise to a constant magnitude rotating magnetic field which induces voltage in the stationary rotor conductors which is short circuited and hence circulates currents in the rotor conductors which produces certain flux and the interaction of stator and rotor fluxes give rise to torque and the rotor starts rotating in the direction of the magnetic field due to stator winding. Initially the frequency of voltages induced in rotor conductors corresponds to supply frequency and as the relative speed between the stator magnetic field and rotor decreases the frequency of the voltage induced in rotor also decreases. Under no load condition the rotor tries to catch up with the stator magnetic field but it can't run at the same speed as the stator magnetic field as otherwise the relative speed will be zero and no voltage would be induced in the rotor conductors and hence no torque will be developed in the rotor. Therefore, the rotor always rotates at a speed less than the synchronous speed of the rotating stator magnetic field. As the motor is loaded the slip between the stator magnetic field and rotor increases. Under no load condition since the rotor has to meet its copper and iron losses only, the slip between the rotor and stator magnetic field is around 1% and as the motor is loaded the slip increases *i.e.* the speed of the rotor decreases. The action is similar to dc shunt motor. The full load slip is normally 5%. The slip is defined as

$$s = \frac{n_s - n_r}{n_s} \quad \dots(8.1)$$

where s is the slip, n_s the synchronous speed of the stator rotating magnetic field, n_r the actual speed of the rotor. The rotor moves in the same direction as the stator field because according to Lenz's law the rotor should move in a direction such that the emf induced in its conductors (or current flow through its conductors) decreases which is possible only if the relative speed between the rotor and the stator magnetic field decreases which means the rotor must rotate in the same direction as the stator magnetic field.

The starting torque of an ordinary (the other one is double cage) squirrel cage motor is limited to approximately double the full load torque when full voltage is applied to the stator winding and under these conditions the starting current is five to eight times its full load value. It, therefore, follows that in cases where high starting torque is required a different type of rotor is necessary. In fact we will see that a double cage rotor or slip ring induction motor with rotor resistances provides high starting torque without drawing large starting current.

In both types of induction motors described the stator carries the primary winding and the rotor the secondary. There may be situations when it is desirable to have the primary on the rotor and the secondary on the stator *e.g.* if the line voltage is high and the secondary current large it would be inconvenient to conduct large current to the rheostat through slip rings. In such a case, the primary wound on the rotor can be supplied with its relatively small current through slip rings, while the stationary secondary terminals can be connected directly to the rheostat. In either case, the revolving magnetic field will travel at synchronous speed with respect to the primary winding. In the first case, it will move at synchronous speed in space, since the primary itself is stationary ; in the second case, it will move in space at a speed corresponding to slip frequency.

The number of rotor slots should not be equal to stator, for if they were, the reluctance of the magnetic circuit would vary from maximum when teeth are opposite slots to minimum when teeth are opposite teeth. Such a pulsation would result in additional core losses and in fact more important is that the rotor would tend to lock with the stator especially at starting with teeth opposite teeth. This can be avoided by making the number of stator and rotor teeth prime to each other, thereby providing a sort of vernier action between the two sets of teeth.

It is desirable to build the stator laminations so that the teeth and slots are parallel to the axis of the shaft but in the case of the rotor the laminations are slightly skewed to eliminate the locking action which is most pronounced if the air gap flux is radially disposed along the whole length of the opposite teeth, the skewing introduces a tangential component into the pull between opposite teeth and so tends to minimise locking action.

The air gap or more accurately the gap between the stator and rotor teeth should be as small as possible so as to have perfect coupling between the stator and rotor magnetic field and thus reducing the leakage flux between the stator (primary) and rotor (secondary) winding. This is desirable as the secondary (rotor) current upon which the torque and power developed depend is supplied inductively from the primary the stator winding and hence good coupling between the two windings is essential. From this point of view the induction motor has similar properties as the transformer and any air gap, however small, will cause the leakage reactance and the magnetising current to be greater than in an equivalent stationary transformer having a closed magnetic circuit. The effect of the air gap is to reduce the p.f. especially at light loads. The length of air gap is, therefore, determined mainly by mechanical consideration to avoid vibration of the shaft and wearing of the bearings and this may be smaller in low speed than in high speed machines.

8.4 EMF AND CURRENT RELATIONS (EQUIVALENT CIRCUIT)

In order to simplify the analysis the assumptions made are

- (i) that the voltage V_1 applied across each phase of primary is purely sinusoidal and alternating at frequency f_1 ;
- (ii) that the flux per pole is sinusoidally distributed in space around the air gap and that it is rotating at synchronous speed and

(iii) that the rotor is equipped with a coil winding arranged for the same number of poles as the primary.

When 3-phase supply is fed to the stator winding it gives rise to a rotating magnetic field of constant magnitude. The voltage induced in the stator winding is

$$E_1 = 4.44 K_1 f_1 N_1 \phi \quad \dots(8.2)$$

where K_1 is a constant which depends upon the distribution of the winding. Similarly the voltage induced in the rotor under stationary condition is

$$E_2 = 4.44 K_2 f_1 N_2 \phi \quad \dots(8.3)$$

While under running condition when the slip is s , the secondary emf is given by

$$sE_2 = 4.44 K_2 s f_1 N_2 \phi \quad \dots(8.4)$$

Each of these two emfs will lag behind ϕ by 90 electrical degrees as in case of a transformer as the currents induced in the secondary are exactly on the same line as in case of transformer. The only difference here is that the frequency of the secondary currents when the rotor is in motion is not same as that of primary (stator) and keeps on varying depending upon the speed of the rotor. Since the secondary (rotor) winding constitutes a closed circuit a current will be produced which is given as

$$I_2 = \frac{sE_2}{\sqrt{R_2^2 + s^2 X_2^2}} = \frac{E_2}{\sqrt{(R_2/s)^2 + X_2^2}} \quad \dots(8.5)$$

where R_2 is the rotor resistance per phase and X_2 is the rotor reactance per phase at frequency f_1 . The two equivalent forms of equation (8.5) suggest two different interpretation.

The first form suggests that the voltage induced in rotor conductors is of frequency $s f_1$ and is of magnitude sE_2 and this emf. acts on a circuit of resistance R_2 and reactance sX_2 and this is in accordance with the actual operating condition. However, the second form suggests that the rotor is stationary and the emf induced is E_2 and this is connected to a variable resistance R_2/s and fixed reactance X_2 at f_1 frequency. Thus the current and emf being of supply frequency. This condition is similar to the transformer and, therefore, the second form of interpretation can be used to draw the equivalent circuit of the induction motor. There is, however, one variation with regard to a transformer. The no load current I_0 in case of induction motor is more in magnitude and leads the flux ϕ more because of the presence of the component of current to supply the friction and windage losses in addition to the core loss. Also I_m the magnetising component of current is larger in case of induction motor due to airgap as compared to the transformer.

Using the second form of equation (8.5) the equivalent circuit of the induction motor is given in Fig. 8.2.

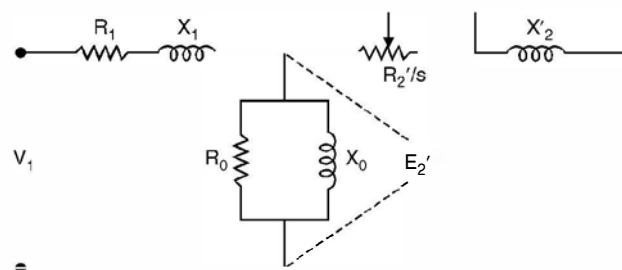

Fig. 8.2. Equivalent circuit of induction motor.

Here R_2' is the equivalent rotor resistance referred to stator side and X_2' is the equivalent rotor reactance at line frequency and referred to the stator side. As in case of transformer, the shunt branch consisting of parallel combination of R_0, X_0 can be shifted to the left of the circuit of Fig. 8.2 as I_0 is negligibly small as compared to I_2' and hence the approximate equivalent circuit is given in Fig. 8.3.

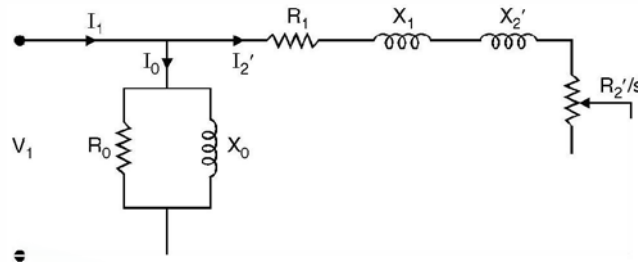

Fig. 8.3. Approximate equivalent circuit of induction motor.

From Fig. 8.3 the secondary current referred to primary side (stator) I_2' is given by

$$I_2' = \frac{V_1}{\sqrt{(R_1 + R_2'/s)^2 + (X_1 + X_2')^2}} \quad \dots(8.6)$$

In the equivalent circuit of Fig. 8.3, the effect of motor load is included in the variable resistance R_2'/s but since

$$\frac{R_2'}{s} = R_2' + \frac{1-s}{s} R_2' \quad \dots(8.7)$$

the approximate equivalent circuit can be redrawn as in Fig. 8.4 (a). Here the resistance R_2' is an inherent part of the internal impedance of the machine but the variable resistance $R_2' \frac{1-s}{s}$ is the electrical analog of the mechanical load. It is this fact which accounts for the concept that the induction motor can be thought of as a generator feeding a fictitious resistance.

8.5 MECHANICAL POWER DEVELOPED

From Fig. 8.3 it is seen that the power input (per phase) to the motor is

$$P_1 = V_1 I_1 \cos \theta_1 \quad \dots(8.8)$$

where the meaning of the symbols is indicated in the phasor diagram of Fig. 8.4 (b) constructed to agree with the circuit of Fig. 8.3.

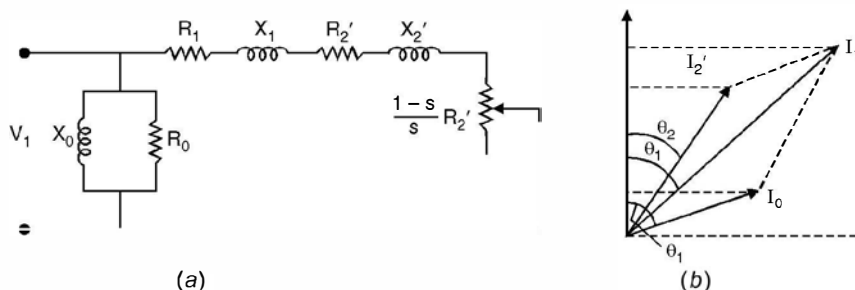

Fig. 8.4. (a) Approximate equivalent circuit of 3-phase induction motor
(b) Power component of current of Fig. 8.3.

A part of the power input to the stator, amounting to $I_2'^2 (R_1 + R_2')$ watts per phase is consumed as copper loss in the primary (stator) and secondary (rotor) windings and the remainder is converted into mechanical power. Not all the mechanical power thus developed is available at the shaft, as there is further loss due to friction windage and core loss. These losses have been taken into account in the equivalent circuit by the shunt branch R_0 and it is seen from phasor diagram 8.4 (b) that it amounts to $V_1 I_0 \cos \theta_0$ watts per phase. The net mechanical power output per phase is, therefore,

$$P = V_1 I_1 \cos \theta_1 - I_2'^2 (R_1 + R_2') - V_1 I_0 \cos \theta_0 \quad \dots(8.9)$$

But from Fig. 8.4 (b)

$$I_1 \cos \theta_1 = I_2' \cos \theta_2 + I_0 \cos \theta_0 \quad \dots(8.10)$$

From Fig. 8.4 (a)

$$I_2' = \frac{V_1}{\sqrt{\left\{ R_1 + R_2' + R_2' \frac{(1-s)}{s} \right\}^2 + (X_1 + X_2)^2}} = \frac{V_1}{Z'} \quad \dots(8.11)$$

and
$$\cos \theta_2 = \frac{R_1 + R_2' + R_2' (1-s)/s}{Z'} \quad \dots(8.12)$$

Substitution of equations (8.10) through (8.12) in equation (8.9) gives

$$P = \frac{V_1^2 R_2'}{(R_1 + R_2'/s)^2 + (X_1 + X_2)^2} \cdot \frac{1-s}{s} \quad \dots(8.13)$$

which gives the mechanical power developed per phase in terms of the slip s , all other terms in the expression being constants of the machine.

Further using equation 8.6 and substituting in equation 8.13 we have

$$P = I_2'^2 \cdot R_2' \frac{1-s}{s} \quad \dots(8.14)$$

which means that the mechanical power developed per phase may be regarded as the ohmic loss in a fictitious secondary resistance of $R_2' \frac{1-s}{s}$ ohms per phase

Now total power input to the secondary (rotor)

= Mechanical power developed + rotor copper loss

$$= I_2'^2 R_2' \frac{1-s}{s} + I_2'^2 R_2' = \frac{I_2'^2 R_2'}{s} \quad \dots(8.15)$$

$$= \frac{\text{Secondary copper loss per phase}}{\text{Slip}} \quad \dots(8.16)$$

On multiplying numerator and denominator of equation (8.13) by s we have

$$P = \frac{V_1^2 R_2' s (1-s)}{(sR_1 + R_2')^2 + s^2 (X_1 + X_2)^2} \quad \dots(8.17)$$

From equation (8.17) it is clear that $P = 0$ when $s = 0$ and $s = 1$ i.e. the output of an induction motor is zero when it is running at synchronous speed or is at standstill. Further the sign of P depends upon the magnitude and sign of s as outlined below :

Case I. s positive, $0 < s < 1$: The motor speed lies between zero and synchronous speed and the direction of rotation of the rotor is same as that of the stator field. The power P is therefore positive and indicates the motor action of the machine.

Case II. s negative, $s < 0$: The rotor rotates in the same direction as the stator field but at a speed higher than the synchronous speed. The relative direction of rotation of the rotor and magnetic field are reversed which induces currents and voltage in the rotor circuit in the reverse direction which means the machine acts as a generator.

Case III. s positive, $s > 1$: The rotor is physically rotating in a direction opposite to the direction of rotation of the magnetic field. The rotor currents and voltages induced are in the same direction as in case I but become greater in magnitude because of the higher relative speed. The machine acts as an electric brake and thus power P is negative.

From equation (8.17)

$$2\pi nT = 2\pi n_s(1-s)T = \frac{3V_1^2 R_2 s(1-s)}{(sR_1 + R_2)^2 + s^2(x_1 + x_2)^2} \quad \dots(8.18)$$

where n = speed of machine

n_s = synchronous speed of machine

Typical torque-speed curves have been drawn in Fig. 8.5, one for the forward direction of rotation and the other for reverse.

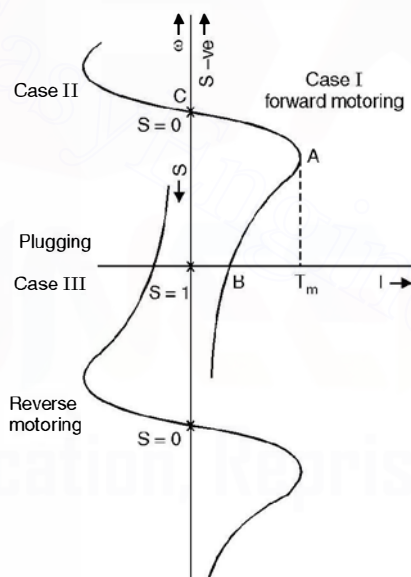

Fig. 8.5. Torque-slip characteristic of induction motor.

The regenerative action of the machine when the rotor rotates in the forward direction, at a speed greater than synchronous speed, is shown by the curve in second quadrant (forward motor curve). However, it is so be noted that this action of the machine is possible only if the system to which the motor is connected supplies reactive power for its excitation.

The maximum torque which the motor can develop is determined by the condition $dT/ds = 0$. On differentiating equation (8.18) with respect to s the condition for maximum torque is

$$s = \pm \frac{R_2}{\sqrt{R_1^2 + (X_1 + X_2)^2}} \quad \dots(8.19)$$

The positive sign stands for motoring action whereas negative sign for generating action. Substituting equation (8.19) for s in equation (8.18)

$$T_{\max} = \frac{3 V_1^2}{\omega_s \times 2 [R_1^2 + (x_1 + x_2)^2]^{1/2}} \quad \dots(8.20)$$

From equations (8.19) and (8.20), it is clear that the slip at which maximum torque occurs depends upon the rotor resistance but the magnitude of maximum torque is independent of rotor resistance. Neglecting R_1 the maximum torque under standstill occurs when

$$R_2 \simeq X_1 + X_2$$

i.e. rotor resistance equals the total leakage reactance. R_2 can be made equal to the leakage reactance only in case of the slip ring induction motor by inserting additional resistance between the slip rings. Corresponding to this operation the p.f. is 0.707. It is to be noted that higher starting torques can be obtained by inserting rotor resistance, but a permanent resistance in the rotor will reduce the efficiency under normal running condition.

In Fig. 8.5, the portion AB of the speed torque Characteristic is the unstable operation of the motor and AC the stable. During the portion AB if the torque developed by the motor is greater than the resisting torque (load torque) the speed continues to increase until the point A (corresponding to maximum torque) is reached. Also if the load torque is greater than the motor torque, the motor starts decelerating along AB till it reaches the point B where the machine comes to a standstill. On the other hand in position AC , if the load torque increases the motor slow down and hence the motor torque also increases and when the two are equal, the motor comes to steady operation.

The torque speed characteristic of a three phase induction motor can be modified by the following methods :

- (i) **Application of Reduced Voltage.** From equations (8.18) and (8.19) it is clear that the torque is proportional to square of voltage and the slip at which the maximum torque occurs is independent of the voltage applied as shown in Fig. 8.6.

From Fig. 8.6, it is clear that the difference between the speed corresponding to maximum torque and the synchronous speed is independent of the voltage applied.

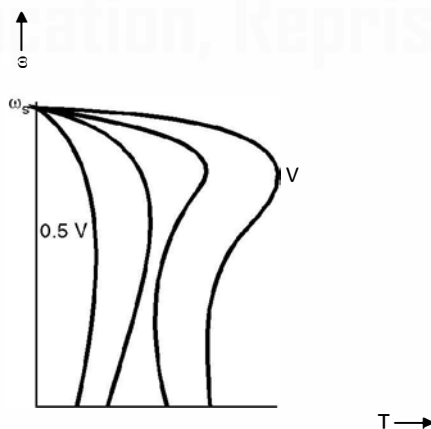

Fig. 8.6. Speed control using reduced voltage.

(ii) **Application of Variable Frequency.** The speed is a function of frequency as given by the synchronous speed equation $f_1 = \frac{n_p}{120}$. The variable frequency can be supplied by a special generator or a frequency changer. While varying frequency, it is necessary to see that the motor retains its shunt characteristics and has adequate overload torque capacity. Both these objectives are achieved by maintaining air gap flux constant. For an induction motor $V_1 \propto f\phi$ or $\frac{V_1}{f} = K\phi$. Therefore, in order to maintain constant air gap flux $\frac{V_1}{f}$ should be kept constant. A set of torque speed characteristics are shown in Fig. 8.7 using variable frequency control.

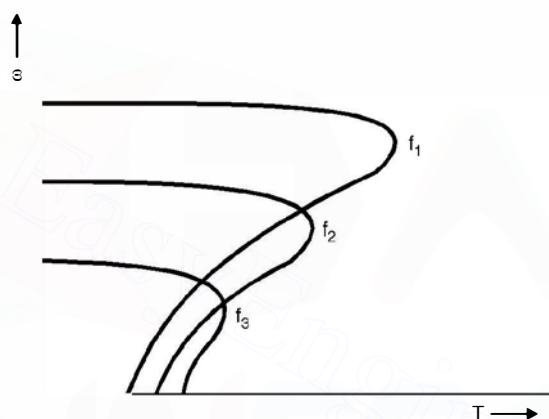

Fig. 8.7. Speed control using variable frequency.

It can be seen that the maximum torque decreases with decrease in frequency below normal frequency. Also with decrease in frequency the slip, at which maximum torque occurs increases. This is partly due to apparent increase in resistance of stator and partly due to the decrease in air gap flux. In order to maintain a high overload torque capacity at low frequencies, it is desirable to decrease the voltage by a lesser degree than the frequency *i.e.* have higher ratio of V/f as frequency is decreased. Variable frequency control provides speed control over the range 10 : 1 to 12 : 1 and high smoothness of control.

(iii) **Addition of Rotor Resistance.** The torque speed characteristic can be modified by inserting resistance in the rotor circuit. Obviously this method is applicable to wound rotor motor. The characteristics are shown in Fig. 8.8 for different values of rotor resistance. It can be seen from Fig. 8.8 that the magnitude of maximum torque is independent of rotor resistance but the slip at which maximum torque occurs is directly proportional to the rotor resistance.

Further, with increase in rotor resistance the starting torque increases upto certain value of resistance, beyond which the starting torque decreases which is due to the enormous decrease in the value of the starting current.

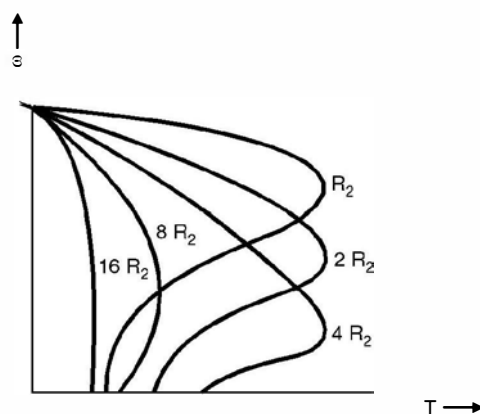

Fig. 8.8. Speed torque curves with rotor resistance control.

- (iv) **Pole Changing.** A squirrel cage rotor is not wound for a specific number of poles, rather it adapts to the same number of poles as the air gap magnetic field, which is determined by the stator winding. The stator winding can be reconnected to multiply the number of poles by a factor of two for a single motor winding. If the motor has two distinct stator windings, then synchronous speeds can be obtained again by reconnecting the windings suitably.
- (v) **Voltage Injection in Rotor Circuit.** Assuming constant supply voltage frequency and load torque and neglecting the voltage drop in the stator, the applied voltage $V_1 \simeq E_1 = K\phi = \text{constant}$. The induced e.m.f. in the rotor is sE_2 where s is the slip and E_2 the induced e.m.f. under standstill condition. The rotor current

$$I_2 = \frac{sE_2}{\sqrt{R_2^2 \pm (s x_2)^2}}$$

Normally, $R_2^2 \gg (s x_2)^2$ therefore, current I_2 is almost in phase with E_2 and is approximately equal to $\frac{s E_2}{R_2}$. Now suppose an e.m.f. E_1 , opposite in phase to E_2 is injected into the rotor (wound rotor). Initially, due to inertia of the rotor, the speed cannot change instantaneously and hence the net e.m.f. in the rotor circuit reduces to $(sE_2 - E_1)$, as a result of which the rotor current and hence the torque developed decrease. With load torque remaining constant the speed decreases (slip increases). This process continues till a new slip $s_i > s$ is achieved, when the rotor induced e.m.f. increases to circulate enough current in the rotor to develop the desired torque. Similarly, if the injected e.m.f. is in phase with the rotor induced e.m.f., the speed of the motor will increase. It should be noted that injected e.m.f. has to be at slip frequency.

Example 8.1. A 12 pole, 3-phase alternator is coupled to an engine running at 500 rpm. It supplies an induction motor which has a full load speed of 1440 rpm. Find the percentage slip and the no. of poles of the motor.

Solution. The frequency of the output of the alternator.

$$f = \frac{pn}{120} = \frac{12 \times 500}{120} = 50 \text{ Hz}$$

The minimum no. of poles can be 2, for which at 50 Hz the synchronous speed is 3000 rpm. Since the full load slip usually is of the order of 5% a speed of 3000 is not possible as the rotor speed given is 1440 rpm.

Next the no. of poles could be 4, for which at 50 Hz the synchronous speed is 1500 rpm and this is close to 1440 rpm. Hence no. of poles is 4 and the percent slip = $\frac{1500 - 1440}{1500} \times 100 = 4\%$. **Ans.**

Example 8.2. If the e.m.f. in the stator of an 8-pole induction motor has a frequency of 50 Hz and that in the rotor $1\frac{1}{2}$ Hz, at what speed is the motor running and what is the slip.

Solution. The supply frequency is 50 Hz whereas the rotor emf frequency is $1\frac{1}{2}$ which means

$$sf = \frac{3}{2} \quad \text{or} \quad s = \frac{3}{2 \times 50} = 0.03$$

Now for 8-pole at 50 Hz the speed comes out to be

$$\frac{120f}{p} = \frac{120 \times 50}{8} = 750 \text{ rpm}$$

Since slip is 0.03, therefore, the actual speed of the rotor is

$$0.03 = \frac{750 - n_r}{750}$$

or

$$\begin{aligned} n_r &= 750(1 - 0.03) = 750 \times 0.97 \\ &= 727.5 \simeq 728 \text{ rpm.} \quad \text{Ans.} \end{aligned}$$

Example 8.3. A 3-phase induction motor has a 4-pole star-connected stator winding. The motor runs on a 50 Hz supply with 200 V between lines. The rotor resistance and standstill reactance per phase are 0.1 ohm and 0.9 ohm respectively. The ratio of rotor to stator turns is 0.67. Calculate (a) total torque at 4% slip (b) total mechanical power at 4% slip (c) maximum torque (d) speed at maximum torque (e) maximum mechanical power. Neglect stator impedance.

Solution. (a) Neglecting stator impedance, the power developed using equation 8.17 is given as

$$P = \frac{V_1^2 R_2' (1-s)s}{R_2'^2 + s^2 X_2'^2}$$

Referring the quantities to rotor side the equation becomes

$$\begin{aligned} \frac{V_2^2 R_2 (1-s)s}{R_2^2 + s^2 X_2^2} &= \frac{0.67^2 \times 200^2 \times 0.1 \times 0.96 \times 0.04}{0.1^2 + 0.04^2 \times 0.9^2} \\ &\simeq \frac{68.95}{0.01} = 6895 \text{ watts} \end{aligned}$$

or

$$\frac{6895}{735} = 9.38 \text{ metric hp.} \quad \text{Ans.}$$

(b) The torque at this slip = $2\pi nT = 6895$

The speed per second = $\frac{1440}{60}$

Hence torque in N-m = $\frac{6895 \times 60}{2\pi \times 1440} = 45.7 \text{ Nm.} \quad \text{Ans.}$

It is to be noted that the motor is star connected and hence the voltage per phase would be $\frac{200}{\sqrt{3}}$ and since the power is to be obtained for all the three phases and the equation 8.17 gives power per phase, therefore we have taken voltage as 200 volts rather than $\frac{200}{\sqrt{3}}$.

(c) The slip at which maximum torque occurs is given by

$$s = \frac{R_2}{X_2} = \frac{0.1}{0.9} = 0.111$$

and

$$P_{\max} = \frac{V_1^2 s (1-s)}{R_2^2 + s^2 X_2^2} = \frac{0.67^2 \times 200^2 \times 0.111 \times 0.889 \times 0.1}{0.1^2 + 0.11^2 \times 0.9^2}$$

$$= \frac{177.188}{0.01 + 0.0098} = 8948.8 \text{ watts}$$

The speed at this slip $1500(1 - 0.111) = 1334 \text{ rpm}$

Hence $T_{\max} = 2459 \text{ Nm}$

Example 8.4. An induction motor has an efficiency of 0.9 when the load is 50 hp. At this load, the stator and rotor copper loss each equals the iron loss. The mechanical losses are one-third of the no load loss. Calculate the slip.

Solution. Let the rotor copper loss be x watts

The total losses are $(x + x + x + x/3) = \frac{10x}{3}$ watts

$$0.9 = \frac{50 \times 735}{50 \times 735 + 10 x/3}$$

$$36750 + \frac{10x}{3} = 40833$$

$$\frac{10x}{3} = 4083 \quad \text{or} \quad x = 1225 \text{ watts}$$

Now rotor copper loss $I_2'^2 R_2'' = 1225$ watts

The load is 36750 watts $= I_2'^2 R_2 \frac{1-s}{s} = 1225 \cdot \frac{1-s}{s}$

$$\text{or} \quad \frac{1-s}{s} = 30 \quad \text{or} \quad 31s = 1 \quad \text{or} \quad s = \frac{1}{31} = 0.032 \quad \text{Ans.}$$

8.6. STARTING OF 3-PHASE INDUCTION MOTORS

Using equation (8.13) the expression for torque can be obtained as follows

$$P = \frac{V_1^2 R_2'}{(R_1 + R_2'/s)^2 + (X_1 + X_2')^2} \cdot \frac{1-s}{s}$$

Now $P = 2\pi n T$ where n is the rotor speed

or $P = 2\pi n_s (1-s) T$ where n_s is the synchronous speed in rps.

$$\text{Hence} \quad T = \frac{V_1^2 R_2'/s}{2\pi n_s [(R_1 + R_2'/s)^2 + (X_1 + X_2')^2]} \quad \dots(8.21)$$

and rewriting equation (8.6) for current we have

$$I = \frac{V_1}{\sqrt{(R_1 + R_2'/s)^2 + (X_1 + X_2')^2}}$$

It is thus seen that contrary to condition with the dc motor, the torque depends on the speed, a feature which gives rise to the well-known torque slip curves of the induction motor. For starting purposes the torque and current at standstill ($s = 1$) are important and these are given by

$$T_s = \frac{V_1^2 R_2'}{2\pi n_s [(R_1 + R_2')^2 + (X_1 + X_2')^2]} \quad \dots(8.22)$$

and

$$I_s = \frac{V_1}{\sqrt{(R_1 + R_2')^2 + (X_1 + X_2')^2}} \quad \dots(8.23)$$

For given value of reactance, therefore, the starting torque and the starting current vary with rotor resistance in the manner shown in Fig. 8.9, the torque reaching a maximum when R_2' is

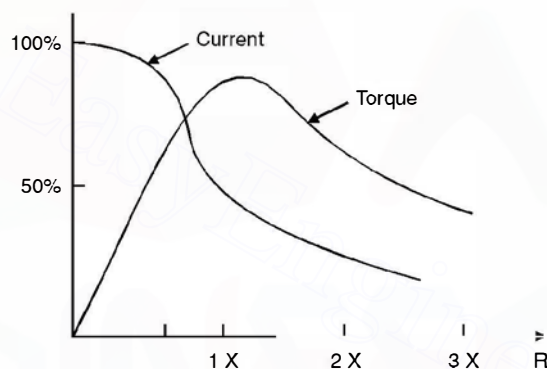

Fig. 8.9. Starting torque and current of induction motor with various values of rotor resistance.

approximately equal to $X_1 + X_2'$. For normal running the value of R_2' should not exceed 1 or 2 per cent of X_2' or the efficiency will be low as there will be lot of ohmic losses in R_2' . Therefore, if starting torque required is high, resistance must be added to the secondary circuit and cut out gradually as the motor speeds up. The resistance also keeps the starting current within allowable limits. This kind of control on rotor resistance is possible in case of slip ring or wound rotor induction motors. However, in case of squirrel cage induction motor, it is not possible to insert resistance in series with the rotor circuit and hence it is inherently a low starting torque motor. As mentioned earlier, the induction motors when running are connected in delta as the torque is proportional to square of the voltage and per phase voltage is the line voltage when the stator is delta connected. Usually motors of 15 to 20 hp are normally connected directly on to the supply without reducing the voltage at starting. However, following methods are used to start induction motors :

(a) Direct on-line starter (b) Star delta starter (c) Auto transformer starting (d) Stator resistance starting. We will now discuss salient features of various starting methods.

(a) **Direct on-line starter.** In this method it is presumed that the motor is already connected in delta for the reason mentioned earlier. Here the motor is connected direct on to the

supply without having any voltage reducing device in between the motor and the supply. The starter has a set of contactor, a no-volt coil and an overcurrent release. Initially as the supply is given to the starter, the no-volt coil is energised and operates the set of contactors which connect supply to the motor. For any reason, if the supply voltage is less than the pick-up voltage of the no-volt coil the contactors will not be operated and the supply will not be connected to the motor. Or during operation if the voltage goes below the drop down voltage of the no-volt coil, the no-volt coil gets deenergized and releases the contactor thereby the motor is disconnected from the supply. This is desirable as for the same load if the voltage goes below certain value the motor will draw large current and hence, it should be instantaneously disconnected. Whenever, the voltage of the system is more than the normal voltage or there is overloading due to any reason the overcurrent release will operate the contactors and disconnect the supply to the motor. This type of starter is normally used for motors rated upto 15 to 20 hp.

(b) **Star delta starter.** In this starter, it is required that all the six terminals of the motor stator winding should be available on the body of the motor as these are connected to the respective terminals of the star delta starter. Here when the starter is operated, initially the winding of motor is connected in star so that the voltage per phase is $\frac{V}{\sqrt{3}}$ where V is the supply line voltage and therefore the starting torque is $\frac{1}{3}$ of the final torque and the starting current is $\frac{1}{\sqrt{3}}$ of the current when V is applied. This is the additional feature of star-delta starter over the direct on line starter. Once the motor runs upto speed, the starter is put on to delta position and the motor stator winding is finally connected in delta under running condition. This method is used for more than 20 hp motors.

(c) **Auto transformer starter.** Here reduced voltage is applied. The reduction of voltage may be carried out by an auto transformer tapping giving 50%, 60% and 75% of normal voltages usually being provided and giving therefore starting torques of 25 per cent, 36 per cent and 56 per cent and starting currents of 50%, 60% and 75% respectively of that obtainable by direct switching.

(d) **Stator resistance starting.** A resistance in series with the stator can be used to limit the starting current but the starting torque available with a given current is less than with an auto transformer and even much less as compared to other methods.

The cost of the stator resistance is, however, less than that of an auto transformer, and it finds application in certain cases where only low starting torques are required.

Before we compare various starting methods through typical example, following relation is derived.

Using equation (8.14) we have

$$P = I_2'^2 R_2' \frac{1-s}{s}$$

Also
$$P = 2\pi n_s T = 2\pi n_s (1-s)T$$

Hence
$$T = I_2'^2 \frac{R_2'}{s} \cdot \frac{1}{2\pi n_s}$$

Starting torque
$$T_s = \frac{1}{2\pi n_s} \cdot I_2'^2 R_2'$$

and Full load torque
$$T_f = \frac{1}{2\pi n_s} \cdot I_{2f}'^2 \frac{R_2'}{s_f}$$

Hence
$$\frac{T_s}{T_f} = \left(\frac{I_{2s}'^2}{I_{2f}'^2} \right) s_f \quad \dots(8.24)$$

By making use of this equation, the starting currents and torques for any particular motor condition can be calculated.

Example 8.5. A 400 V 3-phase squirrel cage induction motor has a full load slip of 4 per cent, a standstill impedance of 1.54 ohms and a full load current of 30 A. The maximum starting current which may be taken from the line is 75 A. What tapping must be provided on an auto transformer starter to limit the current to this value and what would be the starting torque available in terms of the full load torque ?

Solution. Suppose the tapping is t per cent of normal voltage

Normal voltage
$$= \frac{400}{\sqrt{3}} = 231 \text{ volt}$$

Starting current in the motor
$$\frac{t}{100} \times 231 \frac{100}{1.54} \text{ amp}$$

Current on supply side of the auto transformer
$$= \frac{t}{100} \text{ of current in the motor}$$

Therefore, starting current taken from supply
$$= \left(\frac{t}{100} \right)^2 \cdot \frac{231}{1.54} \text{ A}$$

and this is to be limited to 75 A

Hence
$$\left(\frac{t}{100} \right)^2 \cdot \frac{231}{1.54} = 75$$

or
$$t^2 = \frac{75 \times 1.54 \times 100^2}{231} \quad \text{or} \quad t = 70.7$$

i.e. a 70.7 per cent tapping should be provided.

The starting current in the motor

$$= 75 \times \frac{100}{70.7} = 106 \text{ A}$$

Therefore, from equation (8.24)
$$\frac{\text{Starting torque}}{\text{Full load torque}} = \left(\frac{106}{30} \right)^2 \cdot 0.04 = 0.5$$

i.e. the starting torque available would be only half of the full load torque.

Example 8.6. The power input to a 3-phase induction motor is 60 kW. The stator losses total 1 kW. Find the total mechanical power developed and the rotor copper loss per phase if the motor is running with a slip of 3%.

Solution. Total power input to the stator 60 kW

Total stator losses = 1 kW

Therefore total input to the rotor = 59 kW

Using equation 8.15 we have
$$\frac{3I_2'^2 R_2'}{s} = 59 \times 1000 \text{ watts}$$

$$\text{Hence } \frac{3I_2'^2 R_2'}{0.03} = 59000$$

$$\text{Hence rotor copper loss} = I_2'^2 R_2' = \frac{59000 \times 0.03}{3} = 590 \text{ watt per phase}$$

$$\begin{aligned} \text{and mechanical power developed} &= \text{rotor input} - \text{rotor copper loss} \\ &= 59000 - 590 \times 3 = 57.23 \text{ kW. } \quad \text{Ans.} \end{aligned}$$

It is to be noted that the parameters of the induction motor ($R_1, R_2', X_1, X_2', R_0, X_0$) can be obtained on the similar lines as in case of a transformer by performing short circuit (blocked rotor) and open circuit (light running) tests.

Example 8.7. A delta connected, 400 V, 50 h.p. 750 r.p.m. squirrel cage motor takes a full load current of 50 A and has a full load slip of 4.5 per cent. The impedance per phase is 2.5 ohm. Determine the starting torque and the starting current taken from the supply if the motor is started by (i) D.O.L. starter ; (ii) Star-delta starter ; (iii) an auto transformer starter with 70% tapping.

Solution.

(i) D.O.L. Starter

$$\text{The starting current per phase} = \frac{400}{2.5} = 160 \text{ A}$$

$$\text{Therefore Line current} = \sqrt{3} I_{ph} = 277.12 \text{ Ans.}$$

$$\text{Full load torque} = \frac{50 \times 735.5 \times 60}{2\pi \times 750} = 468.47 \text{ Nm.}$$

$$\text{Now } \frac{T_{st}}{T_{fl}} = \left(\frac{I_{st}}{I_{fl}} \right)^2 s_f$$

$$T_{st} = \left(\frac{277.12}{50} \right)^2 \times 0.045 \times 468.47 = 647.57 \text{ Nm } \quad \text{Ans.}$$

(ii) When started by star-delta starter

$$T_{st} = T_f \left(\frac{1}{\sqrt{3}} \right)^2 = \frac{468.47}{3} = 156.15 \text{ Nm } \quad \text{Ans.}$$

Example 8.8. A 3-phase induction motor has 2 poles and is connected to 400 V, 50 Hz supply. Determine the actual rotor speed and the rotor frequency when the slip is 3%.

Solution. The synchronous speed of the motor is given by the relation

$$n_s = \frac{120f}{p} = \frac{120 \times 50}{2} = 3000 \text{ r.p.m.}$$

Since the slip is 3%, the actual speed of rotor

$$n_r = n_s (1 - s) = 3000(1 - 0.03) = 2910 \text{ r.p.m.}$$

The rotor frequency is $sf = 0.03 \times 50 = 1.5 \text{ Hz } \quad \text{Ans.}$

Example 8.9. A 3-phase 50 Hz, 400 V induction motor has 6 poles and operates with a slip of 3% at a certain load. Determine

- (i) the speed of the rotor.
- (ii) the frequency of rotor current.
- (iii) the speed of the rotor magnetic field with respect to stator.
- (iv) the speed of the rotor magnetic field with respect to the rotor.
- (v) the speed of the rotor magnetic field with respect to the stator magnetic field.

Solution. The synchronous speed of the motor is given by

$$n_s = \frac{120f}{p} = \frac{120 \times 50}{6} = 1000 \text{ r.p.m.}$$

- (i) Since the slip is 3% the rotor speed is

$$1000(1 - s) = 1000(1 - 0.03) = 970 \text{ r.p.m.} \quad \text{Ans.}$$

- (ii) The frequency of rotor current $sf = 0.03 \times 50 = 1.5 \text{ Hz}$ **Ans.**

- (iii) The speed of the rotor magnetic field with respect to stator is 1000 r.p.m. **Ans.**

- (iv) The speed of the rotor magnetic field with respect to rotor

$$= \frac{120 \times 1.5}{6} = 30 \text{ r.p.m.} \quad \text{Ans.}$$

- (v) Since the rotor magnetic field and stator magnetic field are rotating at the same speed in the same direction the relative speed is zero. **Ans.**

Example 8.10. A 3-phase delta connected 440 V, 3-phase 50 Hz 4 pole induction motor has a rotor standstill emf per phase of 150 V. If the motor is running at 1450 rpm, determine for this speed (i) the slip (ii) the frequency of rotor induced emf (iii) the rotor induced emf per phase and (iv) stator to rotor turn ratio.

Solution. For 4 pole and 50 Hz, the synchronous speed of the motor is

$$n_s = \frac{120f}{p} = \frac{120 \times 50}{4} = 1500 \text{ r.p.m.}$$

Since the actual speed of rotor is 1450 rpm, the slip is

$$\%s = \frac{n_s - n_r}{n_s} \times 100 = \frac{1500 - 1450}{1500} \times 100 = 3.33\%$$

- (ii) The frequency of rotor induced emf $= sf = 0.0333 \times 50$
 $= 1.66 \text{ Hz}$

- (iii) The rotor induced e.m.f. per phase $sE_2 = 0.0333 \times 150 = 5 \text{ volts}$

- (iv) The stator to rotor turns ratio

$$= \frac{\text{Induced e.m.f. per phase in stator}}{\text{Induced e.m.f. per phase in rotor at standstill}}$$

$$= \frac{440 \text{ (since } \Delta \text{ connected)}}{150} = 44 : 15 \quad \text{Ans.}$$

Example 8.11. A 6-pole, 3 ϕ , 50 Hz induction motor develops a full load torque of 150 Nm when the rotor current makes 120 complete cycles per minute. Determine the shaft power output.

Solution. The synchronous speed of the motor

$$n_s = \frac{120f}{p} = \frac{120 \times 50}{6} = 1000 \text{ r.p.m.}$$

Since the rotor currents makes 120 complete cycles per minute, the frequency of rotor current is $\frac{120}{60} = 2 \text{ Hz}$

Hence $sf = 2$ or $s = \frac{2}{50} = 0.04$ or 4%

The actual speed of the rotor, therefore, is

$$n_r = 1000(1 - s) = 1000(1 - 0.04) = 960 \text{ r.p.m.}$$

The shaft power output = $2\pi n_r T$

$$= 2\pi \times \frac{960}{60} \times 150 = 15.07 \text{ KW Ans.}$$

Example 8.12. A 4-pole, 50 Hz, 3-phase 400 V induction motor develops 20 KW including mechanical losses when running at 1440 rpm and the p.f. is 0.8. Determine (i) rotor current frequency (ii) total input if the stator loss is 1000 W (iii) the line current.

Solution. The rotor current frequency corresponds to slip frequency sf where f is the normal frequency.

(i) Now, the synchronous speed of the motor with 4 pole at 50 Hz is

$$n_s = \frac{120f}{p} = \frac{120 \times 50}{4} = 1500 \text{ r.p.m.}$$

and rotor speed is 1440 r.p.m.

Hence $\% s = \frac{1500 - 1440}{1500} \times 100 = 4\%$

The rotor current frequency is $sf = 0.04 \times 50 = 2 \text{ Hz}$

(ii) Since power input to rotor = $I_2^2 R_{2e} \frac{1-s}{s} + I_2^2 R_2 = I_2^2 R_{2e/s}$

The ratio = $\frac{\text{Mechanical power developed}}{\text{Power input to rotor}}$

$$= \frac{I_2^2 R_2 \frac{1-s}{s}}{I_2^2 R_{2e/s}} = 1 - s$$

Hence power input to rotor = $\frac{\text{Mechanical power developed}}{1 - s}$

$$= \frac{20}{1 - 0.04} = \frac{20}{0.96} = 20.83 \text{ KW}$$

Since stator loss is 1 KW, the total input to the stator is 21.83 KW

(iii) Hence the line current

$$= \frac{21830}{\sqrt{3} \times 400 \times 0.8} = 39.4 \text{ A Ans.}$$

Example 8.13. A 3-phase 400 V, 50 Hz induction motor takes a starting current which is 4 times full load current at rated voltage. It's full load slip is 4%. Determine the auto-transformer ratio which will have starting current not more than 2½ times the full load current at starting. Also determine the starting torque under this condition.

Solution. Suppose the ratio of transformation or tap ratio for auto-transformer is x , then

$$I_{st} = x^2 I_{sc}$$

where I_{sc} is the short circuit current. Dividing by full load current I_f , we have

$$\frac{I_{st}}{I_f} = x^2 \frac{I_{sc}}{I_f}$$

$$2.5 = x^2 \times 4 \quad \text{or} \quad x = 0.79$$

i.e. the tap setting required is 79%

$$\text{Now} \quad \frac{T_{st}}{T_{fl}} = \left(\frac{x I_{sc}}{I_f} \right)^2 \cdot s_{fl} \quad \dots(8.24)$$

$$\begin{aligned} \text{or} \quad T_{st} &= 0.79^2 \times 4^2 \times 0.04 T_{fl} \\ &= 0.399 T_{fl} \\ &\simeq 0.4 T_{fl} \quad \text{or} \quad 40\% \text{ of full load torque.} \end{aligned}$$

Example 8.14. Determine the starting torque of a 3-phase induction motor in terms of full load torque when started by (i) star-delta starter (ii) an auto-transformer starter with 70.7% tapping. The starting current of motor is 5 times the full load current at rated voltage and the full load slip is 4%.

Solution. Starting torque with star-delta starter

$$\begin{aligned} &= \frac{1}{3} \left(\frac{I_{st}}{I_f} \right)^2 s_{fl} T_{fl} \\ &= \frac{1}{3} (5)^2 \times 0.04 T_{fl} = 0.33 T_{fl} \end{aligned}$$

or 33.3% of full load torque.

(ii) Since the voltage applied is 70.7% of the normal voltage and torque is $\propto V^2$ and also starting current will be 0.707 of the current when normal voltage is applied and hence again using equation (8.24) we have

$$\begin{aligned} T_{st} &= \left(\frac{x I_{st}}{I_f} \right)^2 s_{fl} T_{fl} = \left(\frac{0.707 I_{st}}{I_f} \right)^2 \times 0.04 T_{fl} \\ &= \frac{1}{2} \times 5^2 \times 0.04 T_{fl} = 0.5 T_{fl} \end{aligned}$$

The starting torque is 50% of full load torque.

Example 8.15. A 3-phase, 4 pole, 50 Hz induction motor develops 4000 watts at 1440 rpm. Determine the stator input if the stator loss is 320 watts.

Solution. The synchronous speed of the induction motor is

$$n_s = \frac{120f}{p} = \frac{120 \times 50}{4} = 1500 \text{ r.p.m.}$$

and hence the slip is

$$s = \frac{1500 - 1440}{1500} = 0.04$$

Since the power developed is 4000 watts and the slip is 0.04, the power input to the rotor is

$$\frac{4000}{1-s} = \frac{4000}{0.96} = 4167 \text{ watts}$$

Also the stator power loss is given to be 320 watts hence, input to the stator is

$$4167 + 320 = 4487 \text{ watts. Ans.}$$

Example 8.16. A 6-pole 3-phase 50 Hz motor develops mechanical power of 40 hp and has mechanical loss of 1500 watts at a speed of 960 rpm when connected to 500 volts. The power factor is 0.8 lag. Determine (i) rotor copper loss (ii) total input to stator if stator loss is 1800 watts (iii) the line current (iv) efficiency.

Solution. The synchronous speed of the motor for 6 pole and 50 Hz supply is

$$\frac{120 \times 50}{6} = 1000 \text{ r.p.m.}$$

Hence the slip is $\frac{1000 - 960}{1000} = 0.04$

Mechanical power developed = $40 \times 735.5 = 29420$ Watt.

Power input to rotor = $\frac{29420}{1-s} = \frac{29420}{0.96} = 30645.8$ W

(i) Now since power input to rotor is $I_2^2 R_2/s$, the rotor copper loss is $s \cdot I_2^2 R_2/s = I_2^2 R_2$
 $= 0.04 \times 30645.8 = 1226$ Watts.

(ii) Power input to stator = Power input to rotor + stator loss
 $= 30646 + 1800 = 32446$ Watts.

(iii) Hence the line current

$$\frac{32446}{\sqrt{3} \times 500 \times 0.8} = 46.8 \text{ A}$$

(iv) The output available at the shaft

$$= \text{Mechanical power developed} - \text{Mechanical loss}$$

$$29420 - 1500 = 27920 \text{ Watts}$$

Hence $\% \eta = \frac{27920}{32446} \times 100 = 86\%$ Ans.

Example 8.17. A 3-phase 50 Hz 400 V, 25 hp, 4 pole induction motor has the following impedances referred to stator.

$$R_1 = 0.5 \Omega/\text{phase}, \quad R_2 = 0.35 \Omega, \quad X_1 = X_2 = 1.2 \Omega, \quad X_m = 25 \Omega.$$

The combined rotational losses (mechanical and core losses) amount to 800 W and are assumed to remain constant. For a rotor slip of 2.5% at rated voltage and rated frequency, determine (i) the motor speed (ii) the stator current (iii) the p.f. and (iv) the efficiency.

Solution. The equivalent circuit of the motor is shown

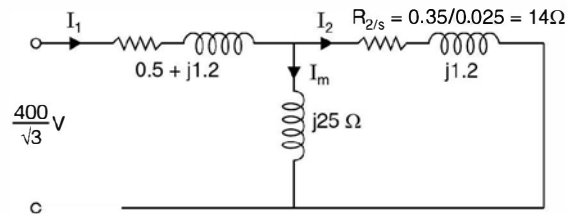

Fig. E8.17

(i) The synchronous speed for 4 pole and 50 Hz supply is 1500 rpm and since the slip is 2.5% the motor speed is $1500(1 - 0.025) = 1462.5$ r.p.m.

(ii) The total impedance as seen from stator terminals

$$z = (0.5 + j1.2) + \frac{j25(14 + j1.2)}{14 + j25 + j1.2}$$

$$= 10.42 + j7.64 = 12.92 \angle 36.3^\circ \Omega$$

Therefore, the stator current is

$$I_s = \frac{400}{\sqrt{3}(12.92 \angle 36.3)} = 17.87 \angle -36.3$$

Stator copper loss = $3 \times 17.87^2 \times 0.5 = 479$ Watt.

(iii) Hence the p.f. angle is 36.3 lag and the p.f. is

$$\cos 36.3 = 0.806 \text{ lag}$$

To find out efficiency we should find out the mechanical power developed, for which we require rotor current.

The rotor current from the diagram

$$I_2 = I_1 \cdot \frac{j25}{j25 + 14 + j1.2} = I_1 \cdot \frac{j25}{14 + j26.2}$$

$$= 17.87 \angle -36.3 \cdot \frac{j25}{14 + j26.2} = 15 \angle -8.2^\circ \text{ Ans.}$$

Therefore, the rotor copper loss is

$$3 \times 15^2 \times 0.35 = 236 \text{ Watts}$$

The power input to motor

$$\sqrt{3} VI \cos \theta = \sqrt{3} \times 400 \times 17.87 \times 0.806$$

$$= 9978 \text{ Watts}$$

The power output is given as

$$\begin{aligned} &\text{Power input} - \text{stator and rotor core and frictional loss} \\ &\quad - \text{stator copper loss} - \text{rotor copper loss} \\ &9978 - 800 - 479 - 236 \\ &= 8463 \text{ Watts} \end{aligned}$$

Hence efficiency of the motor

$$\frac{8463}{9978} \times 100 = 84.8\% \quad \text{Ans.}$$

Example 8.18. A 3-phase 50 Hz, 4 pole, 400 volts induction motor has the following data when referred to stator side.

$$R_1 = 0.2 \Omega, \quad R_2 = 0.15 \Omega, \quad X_1 = j0.5 \Omega, \quad X_2 = j0.3 \Omega$$

The motor operates at 3% slip and the total losses including copper and constant losses are 2000 watts. The core effect may be neglected. Determine (i) the stator current (ii) the p.f. and efficiency of the motor.

Solution. Since the core effect is to be neglected, the equivalent circuit of the motor is given in Fig. E 8.18.

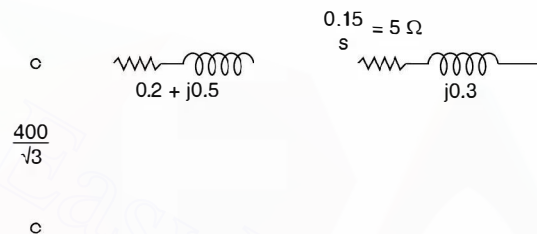

Fig. E8.18

(i) The stator current is given as

$$I = \frac{231(5.2 - j0.8)}{(5.2 + j0.8)(5.2 - j0.8)} = 8.3(5.2 - j0.8)$$

$$= 43.66 \angle -8.750$$

(ii) The p.f. is $\cos 8.75 = 0.988$

(iii) The power input to the stator

$$\sqrt{3} \times 400 \times 43.66 \times 0.988$$

$$= 29884 \text{ Watts}$$

Power output $29884 - 2000 = 27884 \text{ Watts}$

$$\text{Hence} \quad \% \eta = \frac{27884}{29884} \times 100 = 93.3\% \quad \text{Ans.}$$

8.7. INDUSTRIAL APPLICATION

We have so far studied operating characteristics of induction motor. Based on these characteristics following applications are suggested. In agriculture induction motors are invariably used. The other applications are as follows :

Textile mills. In a textile mill, following operations are carried out, cotton to slivers, spinning, weaving and finishing. The process of obtaining slivers from cotton involves, removal of seeds and other impurities from cotton, transformation into laps and finally into slivers. After

this follows spinning where a continuous yarn of sufficient strength is produced which is wound on bobbins. The process of weaving consists of joining two sets of threads, one extends throughout the length of the fabric and the other one has its threads going across. This process is carried out in a loom. The process of finishing consists of bleaching, dyeing, printing, and packing.

Loom motors require high starting torque, frequent starting and stopping and low temperature rise under full load condition. Therefore, totally enclosed fan cooled, high torque squirrel cage induction motors are used.

Spinning motors require moderate starting torque and smooth acceleration, so as to have straight and unbroken yarns. Normally a 4 or 6 pole squirrel cage induction motor is used.

Cement mills. The raw material required consist of limestone, silica, alumina and ferric oxide. The lime stone is crushed and a required amount of iron ore is added and then they are grounded in a grinding mill. The powder from this grinding mill is homogenised in silos, by passage of air from bottom through the medium and is then fed into the kiln, from where cement clinker at high temperature is obtained. This clinker is then air cooled in special type of coolers. The motors used for crushers is the *slip ring* induction motor having 200 to 250% pull out torque.

Coal mining. For drilling in coal mines, usually induction motors with flame proof enclosures are used. Sometimes high frequency (150 to 200 Hz) motors are used. This is done to reduce the size of the motor for the same power ratings. For raising coal or raising or lowering men and some equipments usually wound rotor induction motor is used. While applying brakes, initially d.c. rheostatic braking is used but finally for dead stops, mechanical brakes are used. For large size mines, usually d.c. motor with Ward-Leonard Ilgner system is employed for mine winders.

Lifts. For lifts normally slip ring induction motors having high starting torque, high overload capacity and pull out torques, are used.

Lathe, grinding and milling machine. Here the machine tools require constant operating speed and low starting torque and therefore, d.c. shunt motors or squirrel cage motors are usually used.

Cranes. For cranes or hoist, the requirements are high starting torque and frequent switching operations. For this d.c. series motor is used. In case of a.c. supply, slip ring induction motors are used where speed control is obtained by rotor resistance.

A typical but undesirable operation of a 3-phase induction motor is what is known as single phasing operation of a 3-phase induction motor. Suppose a three-phase induction motor is operating under normal condition of supply and suddenly one of the three phases of the lines blows off. The machine is put on the remaining two phases. This is known as single-phasing operation of a 3-phase induction motor. The machine continues to run but at a slightly reduced speed. A humming noise from the machine is heard. The current in the line becomes $\sqrt{3}$ times its normal value. It is not the quantity of current that is dangerous for the operation of the motor to continue but the quality of current which may overheat the stampings of the rotor which may behave a short-circuited secondary and the stator may draw large current resulting in complete damage of the motor. Therefore, moment humming noise is heard the supply should be switched off from the motor.

PROBLEMS

- 8.1. A delta connected 400 V, 30 hp, 750 rpm squirrel cage motor takes a full load current of 37 A and has a full load slip of 4.5 per cent. The impedance per phase is 3.9 ohms. Determine the starting torque and the starting current taken from the supply if the motor is started by
- Direct switching
 - An auto-transformer starter with a 70% tapping
 - A star-delta starter. **[Ans. (a) 291.6 Nm, 177 A (b) 143 Nm, 86.8 A (c) 97 Nm, 59 A]**
- 8.2. A 3-phase squirrel cage motor has maximum torque equal to twice full load torque $R_2' = 0.2 \Omega$ and $X_2' = 2 \Omega$. Determine the ratio of starting torque to full load torque, if it is started by (a) DOL starter (b) Star-delta starter (c) Auto-transformer starter with 70% tapping.
[Ans. (a) 0.396 FLT (b) 0.132 FLT (c) 0.194 FLT.]
- 8.3. Explain why the rotor of an induction motor rotates in the same direction as the stator magnetic field and why the speed of the motor is less than the synchronous speed.
- 8.4. Explain what you mean by single phasing operation of a 3-phase induction motor.
- 8.5. Comment on the statement
- The rotating fields due to stator and rotor are stationary with respect to each other.
 - Induction motor can be regarded as a generator feeding a fictitious resistance load.
- 8.6. A 4-pole induction motor is running at 1440 rpm from a 50 Hz supply. Find the percentage slip and the frequency of rotor current. **[Ans. 4% 2 Hz]**
- 8.7. A 3-phase induction motor has 4-pole star-connected stator winding and runs on a 220 V 50 Hz supply. The rotor resistance is 0.1 ohm and reactance 0.9 ohm. The ratio of stator to rotor turns is 1.75. The full load slip is 5%. Determine for this load (a) the total torque (b) the horsepower. Also find (c) the maximum torque (d) the speed at maximum torque.
[Ans. 4.28 kgm (b) 8.4 hp (c) 5.73 kgm (d) 1330 rpm.]
- 8.8. A slip ring induction motor runs at 290 rpm on full load when connected to a 50 Hz supply. Calculate (a) the number of poles (b) the slip (c) the slip for full load torque if the total resistance of the rotor circuit is doubled. **[Ans. (a) 20 (b) 3.3% (c) 6.6%.]**
- 8.9. The power input to a 500 V, 50 Hz, 6 pole, 3-phase induction motor running at 975 rpm is 40 kW. The stator losses are 1 kW and the friction windage losses total 2 kW. Determine (a) the slip (b) the rotor copper loss (c) the brake horsepower (d) the efficiency.
[Ans. (a) 0.025 (b) 975 W (c) 48.4 hp (d) 90%.]

CHAPTER

9

Single Phase Induction Motors

9.1 INTRODUCTION

The characteristics of single phase induction motors are identical to 3-phase induction motors except that single phase induction motor has no inherent starting torque and some special arrangements have to be made for making it self starting. It follows that during starting period the single phase induction motor must be converted to a type which is not a single phase induction motor in the sense in which the term is ordinarily used and it becomes a true single phase induction motor when it is running and after the speed and torque have been raised to a point beyond which the additional device may be dispensed with. For these reasons, it is necessary to distinguish clearly between the starting period when the motor is not a single phase induction motor and the normal running condition when it is a single phase induction motor. The starting device adds to the cost of the motor and also requires more space. For the same output a 1-phase motor is about 30% larger than a corresponding 3-phase motor.

The single phase induction motor in its simplest form is structurally the same as a poly-phase induction motor having a squirrel cage rotor, the only difference is that the single phase induction motor has single winding on the stator which produces mmf stationary in space but alternating in time, a polyphase stator winding carrying balanced currents produces mmf rotating in space around the air gap and constant in time with respect to an observer moving with the mmf. The stator winding of the single phase motor is disposed in slots around the inner periphery of a laminated ring similar to the 3-phase motor.

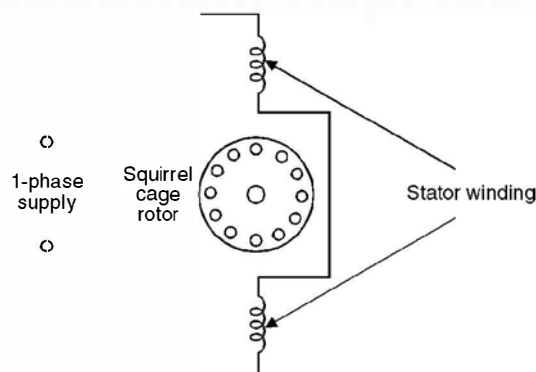

Fig. 9.1. Elementary single phase induction motor.

An induction motor with a cage rotor and single phase stator winding is shown schematically in Fig. 9.1. The actual stator winding as mentioned earlier is distributed in slots so as to produce an approximately sinusoidal space distribution of mmf.

9.2 PRINCIPLE OF OPERATION

Suppose the rotor is at rest and 1-phase supply is given to stator winding. The current flowing in the stator winding gives rise to an mmf whose axis is along the winding and it is a pulsating mmf, stationary in space and varying in magnitude, as a function of time, varying from positive maximum to zero to negative maximum and this pulsating mmf induces currents in the short-circuited rotor of the motor which gives rise to an mmf. The currents in the rotor are induced due to transformer action and the direction of the currents is such that the mmf so developed opposes the stator mmf. The axis of the rotor mmf is same as that of the stator mmf. Since the torque developed is proportional to sine of the angle between the two mmf and since the angle is zero, the net torque acting on the rotor is zero and hence the rotor remains stationary.

For analytical purposes a pulsating field can be resolved into two revolving fields of constant magnitude and rotating in opposite directions as shown in Fig. 9.2 and each field has a magnitude equal to half the maximum length of the original pulsating phasor.

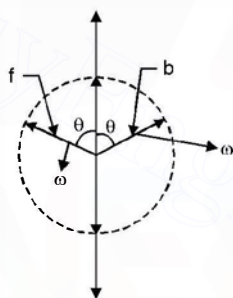

Fig. 9.2. Representation of the pulsating field by space phasors.

These component waves rotate in opposite direction at synchronous speed. The forward (anticlockwise) and backward-rotating (clockwise) mmf waves f and b are shown in Fig. 9.2. In case of 3-phase induction motor there is only one forward rotating magnetic field and hence torque is developed and the motor is self-starting. However, in single phase induction motor each of these component mmf waves produces induction motor action but the corresponding torques are in opposite direction. With the rotor at rest the forward and backward field produce equal torques but opposite in direction and hence no net torque is developed on the motor and the motor remains stationary. If the forward and backward air gap fields remained equal when the rotor is revolving, each of the component fields would produce a torque-speed characteristic similar to that of a polyphase induction motor with negligible leakage impedance as shown by the dashed curves f and b in Fig. 9.3.

The resultant torque-speed characteristic which is the algebraic sum of the two component curves shows that if the motor were started by auxiliary means it would produce torque in whatever direction it was started.

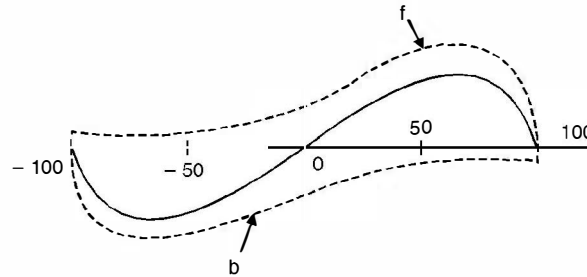

Fig. 9.3. Torque-speed characteristic of a 1-phase induction motor based on constant forward and backward flux waves.

In reality the two fields, forward and backward do not remain constant in the air gap and also the effect of stator leakage impedance can't be ignored. In the above qualitative analysis the effects of induced rotor currents have not been properly accounted for.

When single phase supply is connected to the stator and the rotor is given a push along the forward rotating field, the relative speed between the rotor and the forward rotating magnetic field goes on decreasing and hence the magnitude of induced currents also decreases and hence the mmf due to the induced current in the rotor decreases and its opposing effect to the forward rotating field decreases which means the forward rotating field becomes stronger as the rotor speeds up. However for the backward rotating field the relative speed between the rotor and the backward field increases as the rotor rotates and hence the rotor emf increases and hence the mmf due to this component of current increases and its opposing effect to the backward rotating field increases and the net backward rotating field weakens as the rotor rotates along the forward rotating field. However, the sum of the two fields remains constant since it must induce the stator counter emf which is approximately constant if the stator leakage impedance drop is negligible. Hence, with the rotor in motion the torque of the forward field is greater and that of the backward field is less than what is shown in Fig. 9.3. The true situation being as is shown in Fig. 9.4.

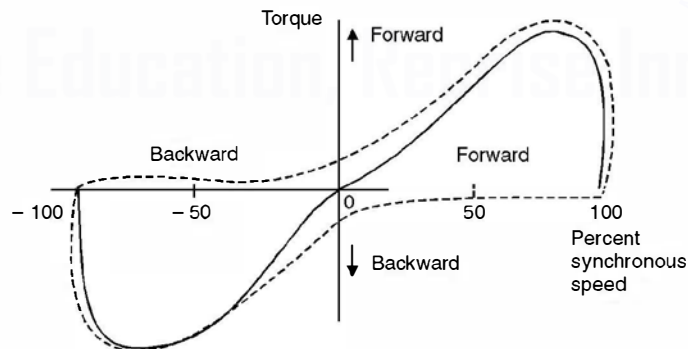

Fig. 9.4. Torque-speed characteristic of a 1-phase induction motor taking into account changes in the flux waves.

In the normal running region at a few per cent slip the forward field is several times stronger than the backward field and the flux wave does not differ materially from the constant

amplitude revolving field in the air gap of a balanced polyphase motor. Therefore, in the normal running range of the motor, the torque-speed characteristic of a single phase motor is not very much different from that of a polyphase motor having the same rotor and operating with the same maximum air gap flux density.

In addition to the torque shown in Fig. 9.4, double-stator frequency torque pulsation are produced by the interaction of the oppositely rotating flux and mmf waves which move past each other at twice synchronous speed. These double frequency torques produce no average torque as these pulsations are sinusoidal and over the complete cycle the average torque is zero. However, sometimes these are additive to the main torque and for another half a cycle these are subtractive and therefore a variable torque acts on the shaft of the motor which makes the motor noisier as compared to a polyphase induction motor where the total torque is constant. Such torque pulsations are unavoidable in single phase circuits. Mathematically

$$T \propto I^2 \quad \dots(9.1)$$

$$\begin{aligned} \text{Let} \quad I &= I_m \sin \omega t \\ T &= K I_m^2 \sin^2 \omega t \\ &= K I_m^2 \frac{(1 - \cos \omega t)}{2} \quad \dots(9.2) \end{aligned}$$

So the expression for torque contains a constant term superimposed over by a pulsating torque with pulsation frequency twice the supply frequency.

9.3 STARTING OF SINGLE PHASE INDUCTION MOTORS

The single phase induction motors are classified based on the method of starting method and in fact are known by the same name descriptive of the method. Appropriate selection of these motors depends upon the starting and running torque requirements of the load, the duty cycle and limitations on starting and running current drawn from the supply by these motors. The cost of single phase induction motor increases with the size of the motor and with the performance such as starting torque to current ratio (higher ratio is desirable), hence, the user will like to go in for a smaller size (hp) motor with minimum cost, of course, meeting all the operational requirements. However, if a very large no. of fractional horsepower motors are required, a specific design can always be worked out which might give minimum cost for a given performance requirements. Following are the starting methods.

(a) **Split-phase induction motor.** The stator of a split phase induction motor has two windings, the main winding and the auxiliary winding. These windings are displaced in space by 90 electrical degrees as shown in Fig. 9.5 (a). The auxiliary winding is made of thin wire (super enamel copper wire) so that it has a high R/X ratio as compared to the main winding which has thick super enamel copper wire. Since the two windings are connected across the supply the current I_m and I_a in the main winding and auxiliary winding lag behind the supply voltage V , I_a leading the current I_m Fig. 9.5(b). This means the current through auxiliary winding reaches maximum value first and the mmf or flux due to I_a lies along the axis of the auxiliary winding and after some time ($t = \theta/\omega$) the current I_m reaches maximum value and the mmf or flux due to I_m lies along the main winding axis. Thus the motor becomes a 2-phase unbalanced motor. It is unbalanced since the two currents are not exactly 90 degrees apart. Because of these two fields a starting

torque is developed and the motor becomes a self-starting motor. After the motor starts, the auxiliary winding is disconnected usually by means of centrifugal switch that operates at about 75 per cent of synchronous speed. Finally the motor runs because of the main winding. Since this being single phase some level of humming noise is always associated with the motor during running. A typical torque speed characteristic is shown in Fig. 9.5 (c). It is to be noted that the direction of rotation of the motor can be reversed by reversing the connection to either the main winding or the auxiliary windings.

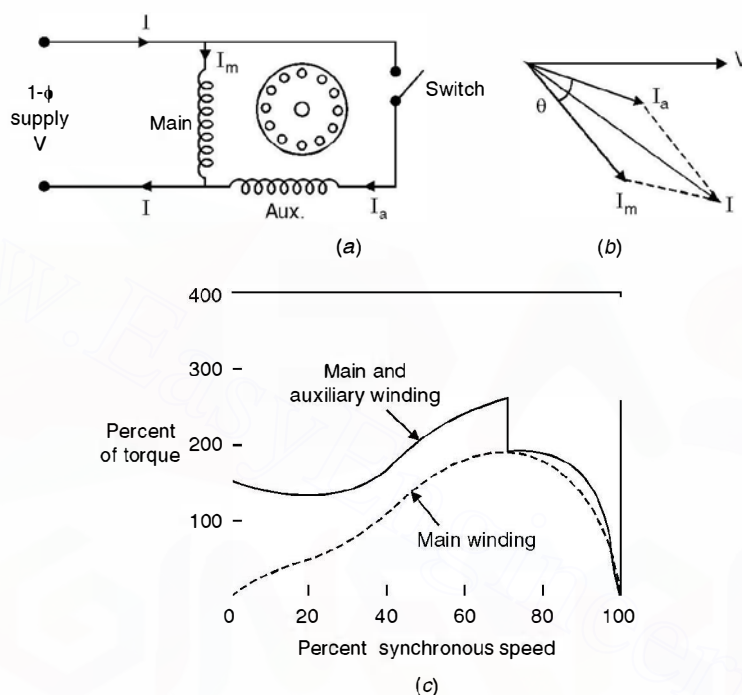

Fig. 9.5. Split phase induction motor (a) Connection (b) Phasor diagram at starting (c) Typical torque-speed characteristic.

(b) **Capacitor start induction motor.** Capacitors are used to improve the starting and running performance of the single phase inductions motors.

The capacitor start induction motor is also a split phase motor. The capacitor of suitable value is connected in series with the auxiliary coil through a switch such that I_a the current in the auxiliary coil leads the current I_m in the main coil by 90 electrical degrees in time phase so that the starting torque is maximum for certain values of I_a and I_m . This becomes a balanced 2-phase motor if the magnitude of I_a and I_m are equal and are displaced in time phase by 90° electrical degrees. Since the two windings are displaced in space by 90 electrical degrees as shown in Fig. 9.6 maximum torque is developed at start. However, the auxiliary winding and capacitor are disconnected after the motor has picked up 75 per cent of the synchronous speed. The motor will start without any humming noise. However, after the auxiliary winding is disconnected, there will be some humming noise.

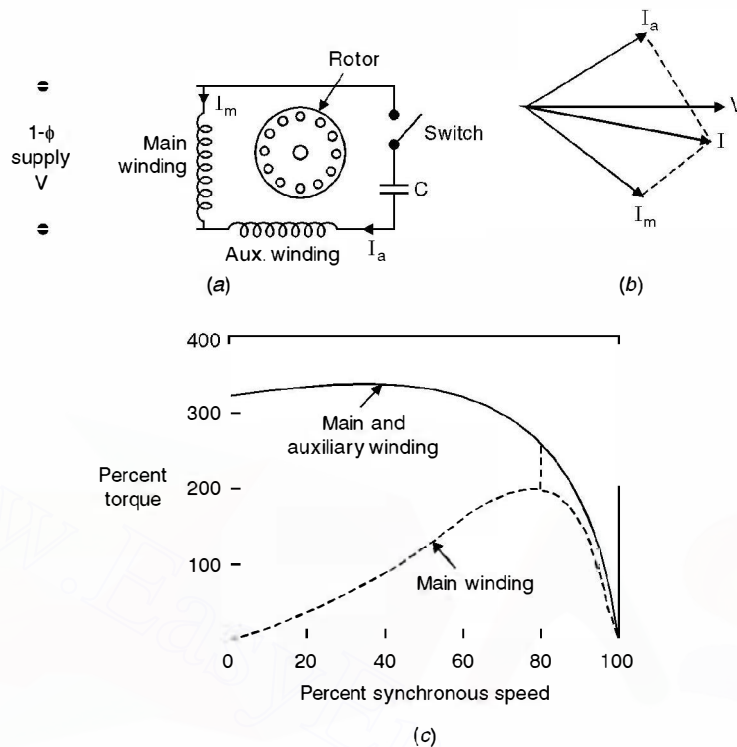

Fig. 9.6. Capacitor start motor (a) Connection (b) Phasor diagram at start (c) Speed torque curve.

Since the auxiliary winding and capacitor are to be used intermittently, these can be designed for minimum cost. However, it is found that the best compromise among the factors of starting torque, starting current and costs results with a phase angle somewhat less than 90° between I_m and I_a . A typical torque-speed characteristic is shown in Fig. 9.6 (c) high starting torque being an outstanding feature.

(c) **Permanent-split capacitor motor.** In this motor the auxiliary winding and capacitor are not disconnected from the motor after starting, thus the construction is simplified by the omission of the switch as shown in Fig. 9.7 (a).

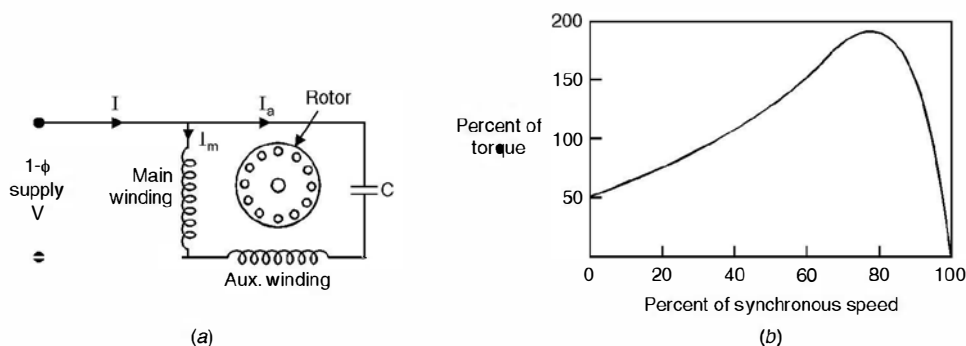

Fig. 9.7. Permanent split capacitor motor (a) Connection (b) Torque-speed characteristic.

Here the auxiliary winding and capacitor could be so designed that the motor works as a perfect 2-phase motor at anyone desired load. With this the backward rotating magnetic field would be completely eliminated. The double stator frequency torque pulsations would also be eliminated, thereby the motor starts and runs as a noise free motor. With this there is improvement in p.f. and efficiency of the motor. However, the starting torque must be sacrificed as the capacitance is necessarily a compromise between the best starting and running characteristics. The torque-speed characteristic of the motor is shown in Fig. 9.7 (b).

(d) **Capacitor start capacitor run motor.** If two capacitors are used with the auxiliary winding as shown in Fig. 9.8 (a), one for starting and other during the start and run, theoretically optimum starting and running performance can both be achieved.

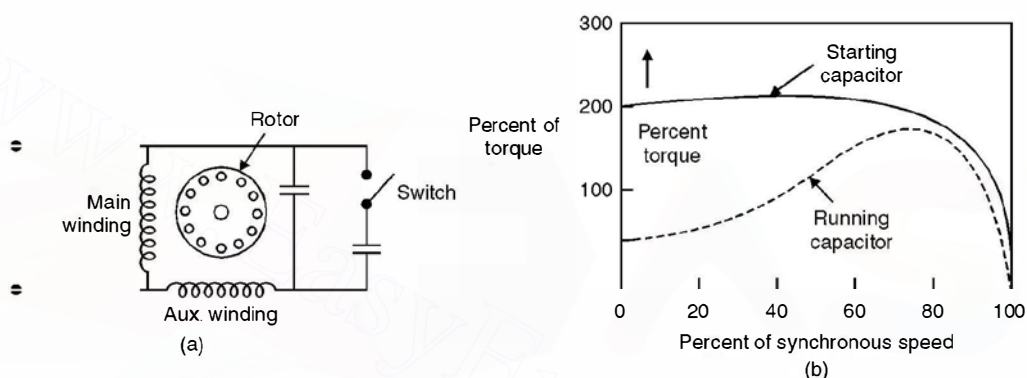

Fig. 9.8. (a) Capacitor start capacitor run motor (b) Torque-speed characteristic.

The small value capacitor required for optimum running conditions is permanently connected in series with the auxiliary winding and the much larger value required for starting is obtained by a capacitor connected in parallel with the running capacitor. The starting capacitor is disconnected after the motor starts.

The value of the capacitor for a capacitor start motor is about $300\ \mu\text{F}$ for $\frac{1}{2}$ hp motor. Since this capacitor must carry current for a short starting period, the capacitor is a special compact ac electrolytic type made for motor starting duty. However, the capacitor permanently connected has a typical rating of $40\ \mu\text{F}$; since it is connected permanently, the capacitor is an ac paper, foil and oil type. The cost of the motor is related to the performance; the permanent capacitor motor is the lowest cost, the capacitor start motor next and the capacitor start capacitor run has the highest cost.

(e) **Shaded pole induction motor.** Fig. 9.9 (a) shows schematic diagram of shaded pole induction motor. The stator has salient poles with one portion of each pole surrounded by a short-circuited turn of copper called a shading coil. Induced currents in the shading coil (acts as an inductor) cause the flux in the shaded portion of the pole to lag the flux in the other portion. Hence the flux under the unshaded pole leads the flux under the shaded pole which results in a rotating field moving in the direction from unshaded to the shaded portion of the pole and a low starting torque is produced which rotates the rotor in the direction from unshaded to the shaded pole. A typical torque speed characteristic is shown in Fig. 9.9 (b). The efficiency is low. These motors are

the least expensive type of fractional horse power motor and are built upto about $\frac{1}{20}$ hp. Since the rotation of the motor is in the direction from unshaded towards the shaded part of the pole, a shaded pole motor can be reversed only by providing two sets of shading coils which may be opened and closed or it may be reversed permanently by inverting the core.

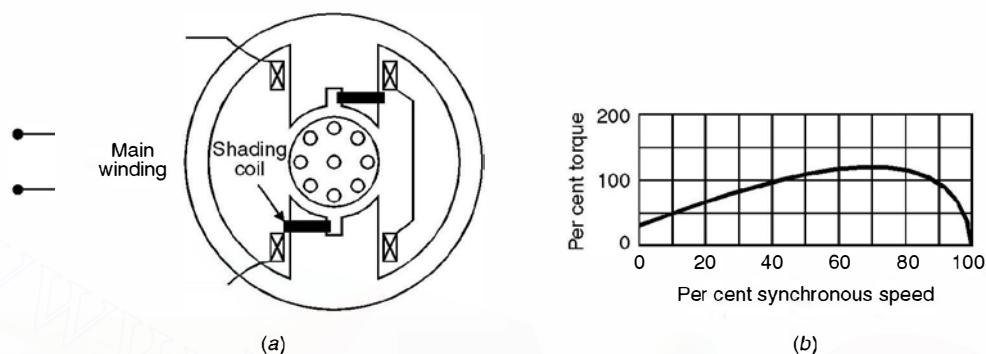

Fig. 9.9. Shaded-pole motor and typical torque-speed characteristic.

9.4 APPLICATION

The split phase induction motors are used for fans, blowers, centrifugal pumps and office equipments. Typical ratings are $\frac{1}{20}$ to $\frac{1}{2}$ hp; in this range they are the lowest cost motors available. The capacitor start motors are used for compressors, pumps, refrigeration and air-conditioning equipments and other hard to start-loads.

The capacitor start capacitor run motors are manufactured in a number of sizes from $\frac{1}{8}$ to $\frac{3}{4}$ hp and are used in compressors, conveyors, pumps and other high torque loads. The permanent split capacitor motors are manufactured in the range of $\frac{1}{20}$ hp to $\frac{3}{4}$ hp and are used for direct connected fans, blowers, centrifugal pumps and loads requiring low starting torque.

The shaded pole motors are used in toys, hair driers, deskfans etc.

9.5 UNIVERSAL MOTOR

We know that single phase motors are not self starting. We have to provide additional features to make it self starting.

The other solution to the single phase problem is to design a d.c. motor so that it will run on a.c. as well. The direction of rotation of a d.c. machine depends upon the polarities of the armature circuit and the field circuit. If a d.c. machine is designed so that (i) when line current reverses direction the field and armature currents reverse simultaneously and (ii) the core loss with alternating flux is relatively low, then a successful single phase machine results.

The first criterion is met by connecting armature and field windings in series. The second is achieved by using a laminated core. A d.c. shunt motor on the other hand can not be used on

a.c. because of high inductance of the field winding as compared to armature winding which causes the field pole reversals to be out of phase with the current reversals in the armature and the result is that the torque is backward during part of each half cycle lowering average torque and reducing the efficiency.

A d.c. series motor designed to operate also on a.c. is called a universal motor as it will run efficiently on any frequency from d.c. upto its design frequency. Fig. 9.10 shows the principle of operation of the motor.

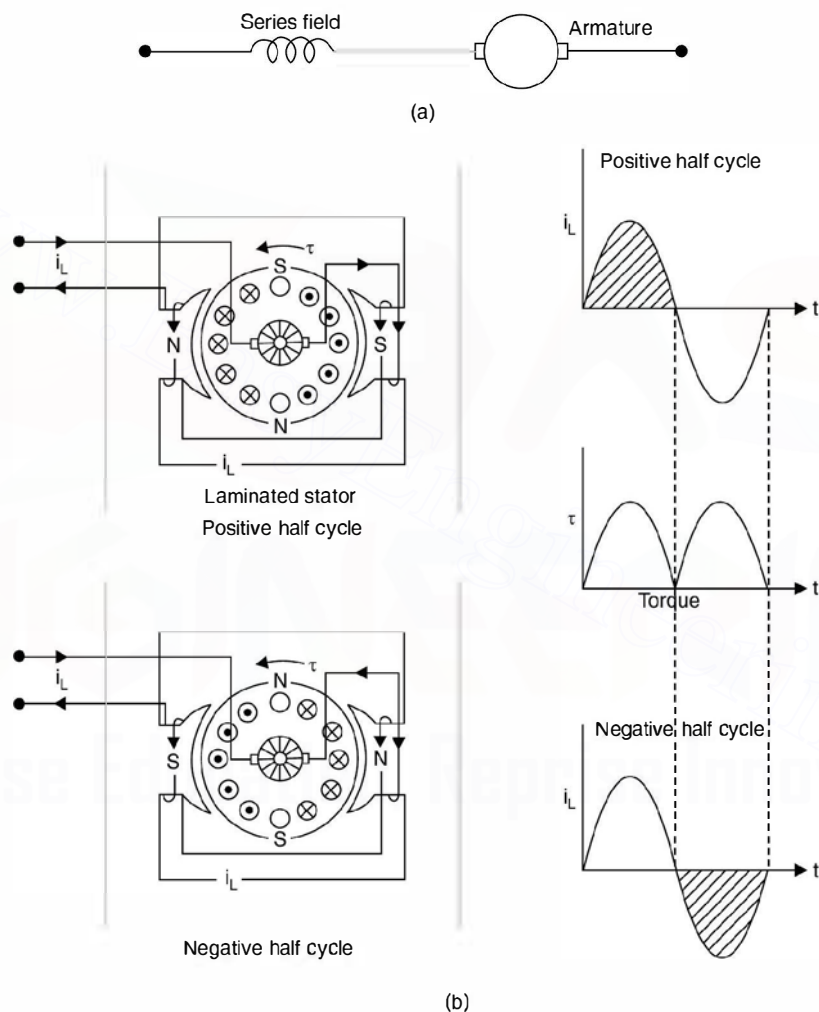

Fig. 9.10 The universal motor. (a) Circuit diagram. (b) Principle of operation.

Universal motors are designed for voltages ranging from 32 to 250 volts, frequencies zero to 60Hz and ratings upto 3/4 hp. The average speed is high in the range of 7000 rpm at normal load. The torque/speed characteristic of the motor is shown in Fig. 9.11 No load speed is quite high often in the range of 20,000 rpm. It is limited by windage and friction. Having high speed capability, universal motor of a given horse power rating is significantly smaller than other

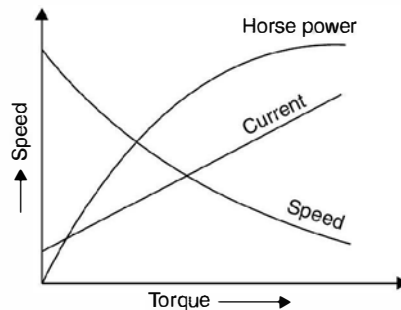

Fig. 9.11 Characteristics of universal motors.

kinds of a.c. motors operating at the same frequency. Their starting torque is relatively high. These characteristics make universal motors ideal for devices such as hand drills, hand grinders, food mixers, vacuum cleaners and the like which require compact motors operating at speeds greater than 3000/3600 rpm. Universal motors must be designed with weak magnetic fields to minimise commutation difficulties. High resistance carbon brushes are used to limit the circulating current due to the transformer voltage in the short circuited coils.

9.6 SYNCHROS

The terms synchros and Selsyn (abbreviation of self synchronisation) are both used to refer to a special wound rotor induction motors which are used in pairs to provide shaft position control and/or synchronism of two remote machines. Applications vary from controlling valves to indicating the position of some remote devices. Usually the primary winding is a single phase winding located on the rotor whereas the stator has a three phase winding which acts as the secondary whereas usual standard wound rotor induction motors could be used for the purpose, synchros usually have low inertia and low friction bearings to reduce error and mechanical dampers to improve dynamic performance. Fig. 9.12 shows application of synchros for low torque requirements. Here both the rotors are supplied from the same a.c. source. An unbalanced set of three single phase voltage (in time with the single phase rotor voltage) will be induced in the stator phase windings of both the machines. These voltages will be equal if and only if the two rotors are exactly in the same position. Assuming one machine is the transmitter, its rotor position will be fixed by the controlling mechanical input. If the rotor of the other machine is considered as receiver and if it is not at the same position, unequal phase voltages will exist. This will result in stator current, thus mmf and the torque seeking to align the receiver's rotor position with that of the transmitter.

Equilibrium is reached when the output torque decreases to equal the torque required by the transmitter's load. Therefore, it is necessary that the load torque be small and that friction be minimised in the synchros.

Synchros are also constructed with three phase rotor windings. For low torque applications, it is common to supply both transmitter and receiver stator windings from the same three

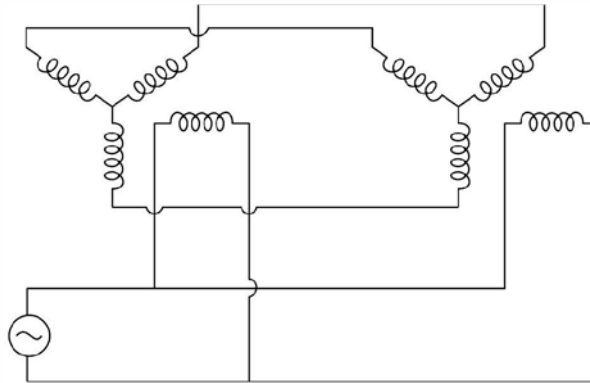

Fig. 9.12. Low-torque synchros system.

phase source. The rotor windings are then connected in parallel. Again by Faraday's law, flux distribution must be the same in both the machines. Equilibrium will exist in the rotor circuit only when the rotors are synchronised at the same relative positions. Otherwise, a torque will be produced which tends to align the two rotors.

9.7 DC TACHOMETER

It is sometimes necessary in control systems to feed back a voltage proportional to the speed of the shaft. In a d.c. servomechanism this can be achieved by using a d.c. tachometer which is a permanent magnet d.c. generator. The field is due to permanent magnet which ensures that the voltage output will be directly proportional to the speed.

A d.c. tachometer can be used on a.c. servomechanism by converting the d.c. output voltage to an a.c. voltage by using an inverter circuit.

9.8 AC TACHOMETER

An a.c. tachometer is used in feedback control system to feedback an a.c. voltage proportional to the speed of the shaft. This is basically a two-phase induction motor as shown in Fig. 9.13. One of the stator windings is used as the reference winding and the other the control winding. The reference winding is fed a suitable a.c. voltage of constant frequency and magnitude. Therefore, a voltage of the same frequency is induced in the control winding. This output voltage is fed to the high input impedance circuit of an amplifier so that the control winding can be considered as open circuited. It is essential that the voltage induced in the control winding is directly proportional to the shaft speed and phase of this voltage be fixed with respect to voltage supplied to the reference winding.

The principle of operation of an a.c. tachometer can be explained using double revolving field theory. With reference to reference winding the tachometer can be considered equivalent to a single phase induction motor. At standstill, the forward and backward fields are equal and hence voltage induced in the control winding is zero.

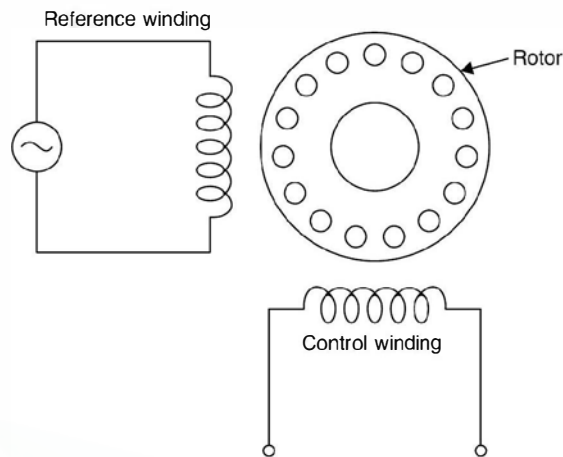

Fig. 9.13. AC tachometer.

When the rotor is revolving, the rotor current due to forward rotating field decreases since its effective impedance increases whereas for the backward rotating field the impedance decreases, the difference between them being function of speed. Therefore, the voltage developed across control winding is a function of speed. Reversal of direction of rotation reverses the phase of output voltage.

For a constant phase angle of output voltage and linear relationship between output voltage and speed, a suitable value of ratio of rotor reactance to rotor resistance should be chosen. If it is low, the sensitivity *i.e.* volts per revolution per minute is sacrificed but linear speed range is wide. However, if it is high the speed range is limited to a fairly small fraction of synchronous speed to meet the condition of linearity of voltage and consistency of phase angle. An a.c. tachometer should have low inertia when rapid speed variations are encountered as in automatic control system.

9.9 TWO PHASE SERVOMOTOR

A two-phase servomotor is commonly used in feed back control system to drive the loads and as sensors to measure speed and position of the controlled element. It is basically a two-phase induction motor with squirrel cage rotor. The rotor has high resistance so that a negative slope (increase in torque results decrease in speed and vice versa) for the torque speed characteristics over the entire operating range is obtained. The negative slope characteristic provides stable operation and positive damping. The ratio of rotor diameter to its length is small so that its moment of inertia is small and hence it gives good acceleration characteristic. The motor is quite rugged and reliable and is used in different range from a fraction of a watt to about hundred watts.

Fig 9.14 shows schematic diagram of a 2-phase servomotor. One of the stator windings is known as a reference winding and is excited by a fixed a.c. voltage V_r , whereas the second winding known as control winding is excited by the control voltage V_c . For production of torque it is necessary that the two voltages should be in synchronism. Hence the two voltages must be derived from the same source. The control voltage is fed to the motor through an amplifier. Also the two voltages must have a phase difference of 90° (balance 2-phase operation where the torque is maximum).

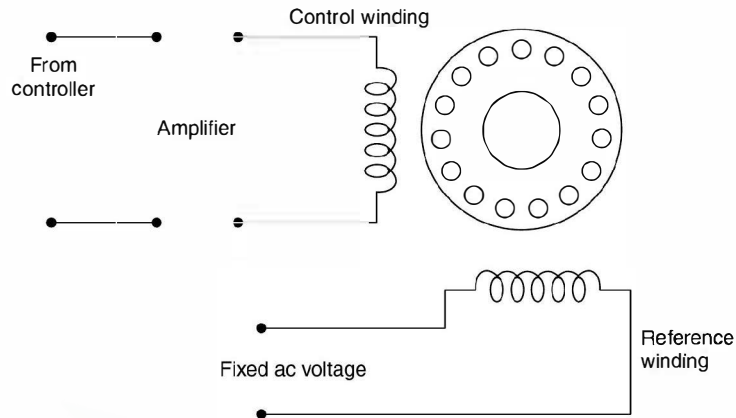

Fig 9.14 Two-phase servomotor.

This phase shift can be obtained either by using a phase shifting network in the amplifier or by adding a capacitor in series with the reference winding. When the control voltage leads the reference voltage, rotation in one direction is obtained and when control voltage lags the reference voltage, rotation in the opposite direction is obtained. Since for constant phase angle say 90° between V_c and V_r , the torque is a function of V_c and V_r , changing the magnitude of V_c , the torque developed changes.

Fig. 9.15 shows the torque-speed characteristics of a two-phase servo motor for different values of control voltages and unity reference voltage. The slope of the characteristic is negative for stable operation. The torque is high at zero speed. The maximum torque is developed at a source speed of one-half the synchronous speed which means the rotor will run stably near its zero speed.

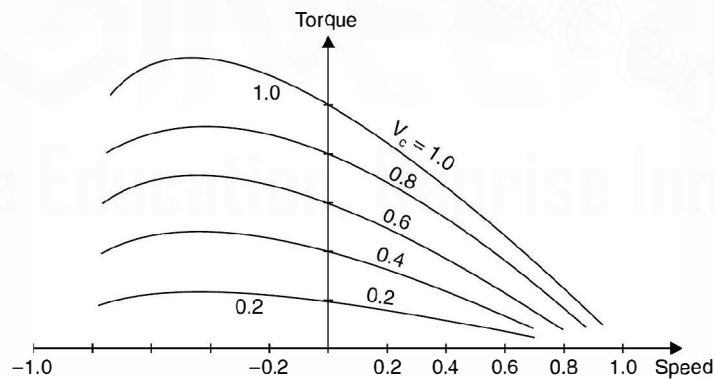

Fig. 9.15. Torque-speed curve of two-phase servomotor.

PROBLEMS

- 9.1. Explain why 3-phase induction motor is self-starting and 1-phase is not.
- 9.2. Explain with the help of schematic diagram and phasor diagram the principle of operation of 1-phase split phase induction motor.

- 9.3. Describe how to reverse the following single phase induction motors (a) Resistance split phase (b) Capacitor start (c) Permanent slip capacitor (d) Two value capacitor (e) Shaded pole motor.
- 9.4. A single phase induction motor has poor performance as compared to a 3-phase induction motor. Discuss the reasons.
- 9.5. Discuss the differences between capacitor start, capacitor start capacitor run and permanent split capacitor motors.
- 9.6. What is a universal motor ? Explain with neat diagram construction, principle of operation and application of the motor.
- 9.7. What is a two-phase servomotor ? Give its application. Draw the connection diagram and its speed torque characteristic.
- 9.8. Explain what you mean by stable operation of a two-phase servomotor and how it is achieved.
- 9.9. What is a synchro ? Explain with neat diagram the working of a synchro transmitter system and give its application.
- 9.10. Discuss the function of an a.c. tacho-generator. Explain with neat diagram the construction and principle of operation.

CHAPTER

10

Power System

10.1 INTRODUCTION

Electric power system is the most capital intensive and the most complex system ever developed by man.

An electric power system consists of three major components; (i) Generation, (ii) Transmission and (iii) Distribution. A system may or may not have transmission component depending upon the distances of the generating system from the consumers of electric energy but distribution is an integral part of any electric power system. The intermediate phase between the generation and distribution has come into existence because of the long distances between the energy sources and the sinks (consumers). Electrical transmission is the most efficient method of transmitting power over long distances. Transmission system can further be classified as (i) primary transmission (275 KV and above) and (ii) secondary transmission (220 K V to 66 K V) depending upon the level of voltage used for transmission. Similarly distribution system can be further classified as (i) primary distribution (33 KV and above), (ii) secondary distribution (11 KV/6.6 KV/ 3.3 KV) and (iii) tertiary distribution (400 volts 3 phase) depending upon the voltage of distribution. A single line diagram of a typical electrical power system is shown in Fig. 10.1.

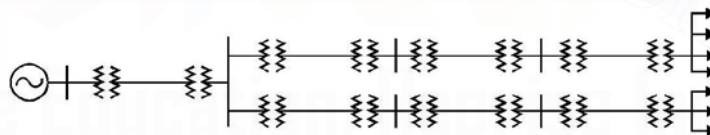

Fig. 10.1. A Typical Electric Power System.

Distribution system has two components (i) Feeder and (ii) Distributor. A feeder in a distribution network is a circuit carrying power from a main substation to a secondary substation, such that the current loading is the same all along its length. Therefore, the main criterion for the design of a feeder is its current carrying capacity (thermal limits rather than voltage drops). A distributor, on the other hand, has variable loading along its length due to the service connections, tapped off at intervals by the individual consumers. The voltage variation at consumer's terminals must be maintained within $\pm 5\%$ in order to avoid unsatisfactory operation of equipment, e.g. a reduction in voltage will adversely affect the output of an induction motor or light from a filament lamp. Therefore, the main criterion for the design of a distributor is the voltage drop, which must be kept within certain limits. A typical distribution system in a city area is shown in Fig. 10.2.

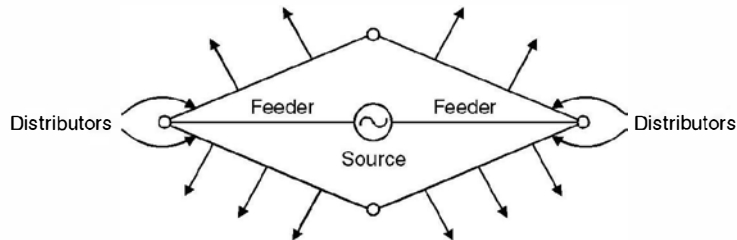

Fig. 10.2. A Typical Distribution System.

The distribution system occupies an important place in any electric power system. The effectiveness with which it achieves its objective of distributing electric energy to various consumers, is measured in terms of voltage regulation, flexibility, security of supply efficiency and cost.

10.2 TYPES OF DISTRIBUTION SYSTEM

Depending upon the type of supply, distribution system can be classified as follows :

- (i) a.c. single phase (single phase loads only);
- (ii) 3-phase, 3-wire (3 phase loads only); and
- (iii) 3-phase, 4-wire (all types of loads).

The distribution system can also be classified depending upon the connections. These are the following two systems :

- (i) Radial system and
- (ii) Ring Mains system.

10.2.1 The Radial Systems

The electric energy distribution originally was through radial system. A typical radial distribution system is shown in Fig. 10.3.

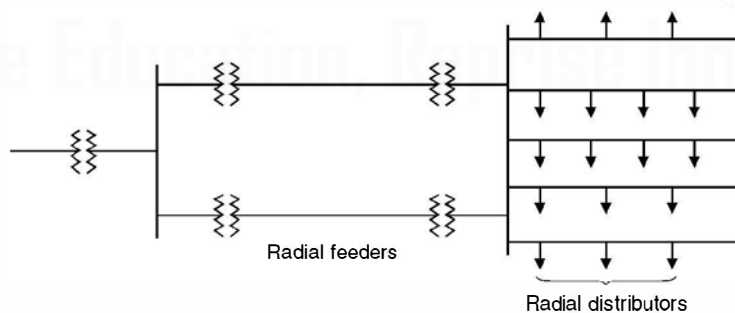

Fig. 10.3. Radial Distributors.

The advantages of radial system are its simplicity and low cost, which result from a straight forward circuit arrangement where a single or radial path is provided between the consumer and the source or bulk power supply. With such an arrangement, the amount of switching equipment required is small and the protective relaying is simple. The major disadvantage of radial system

is its lack of security of supply. When a fault occurs on any section of the feeder, a number of consumers will be without supply for a considerable period. The radial system is normally used for rural distribution these days.

10.2.2 The Ring Mains Systems

The system is used most frequently to supply bulk loads such as small industrial loads and medium or large commercial buildings where continuity of supply is of considerable importance. A typical ring mains for feeder and distributors is shown in Fig. 10.4 (a).

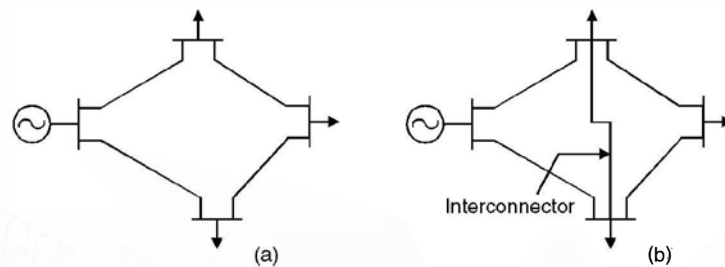

Fig. 10.4. Ring Mains (a) Ring (b) interconnected.

It can be shown that when an interconnector is used in a ring mains system [Fig. 10.4 (b)], it reduces the voltage drop between the points to which it is connected. The ring mains systems is used for urban distribution in contrast to the radial system.

10.3 COST COMPARISON OF SUPPLY SYSTEMS

The various systems considered for cost comparison are

- (i) d.c. two wires
- (ii) a.c. single phase two wire
- (iii) a.c. three phase four wire.

The terms of comparison are (a) same maximum phase to ground voltage and (b) same efficiency or losses to transmit a given amount of power over a given distance. The quantity to be compared is the volume of copper required in each case.

D.C. two wire with midpoint earthed

Refer to Fig. 10.5 for d.c. two-wire midpoint earthed system. Let V be the voltage between either outer terminal and the earth so that voltage between the two outer terminals is $2V$. Let P be the power transmitted. Therefore, the current in each outer conductor will be $I = \frac{P}{2V}$. If R_1 is the resistance of each conductor the copper loss will be

$$\text{Copper loss} = \frac{2P^2}{4V^2} R_1 = \frac{P^2}{2V^2} R_1$$

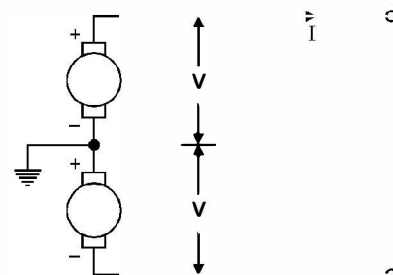

Fig. 10.5. D.C. Two-Wire System.

A.C. Single Phase Two-Wire

Refer to Fig. 10.6 for a.c. single phase two-wire system with middle point earthed. The maximum voltage between one of the outer wires and the earth is V volts. Therefore,

$$V_{rms} = \frac{V}{\sqrt{2}}$$

The voltage between the two outer conductors is $\frac{2V}{\sqrt{2}} = \sqrt{2}V$

Therefore current in the outer wire $I = \frac{P}{\sqrt{2} V \cos \phi}$ if ϕ is the power factor angle of the load.

Now if R_2 is the resistance of each wire, the copper loss = $2 \cdot \frac{P^2}{2V^2 \cos^2 \phi} R_2$

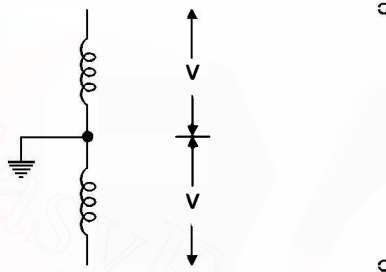

Fig. 10.6. A.C. Two Wire System.

$$\text{Copper loss} = \frac{P^2}{V^2 \cos^2 \phi} R_2$$

A.C. 3-phase 4-wire system Refer to Fig. 10.7 for a 3-phase, 4-wire system

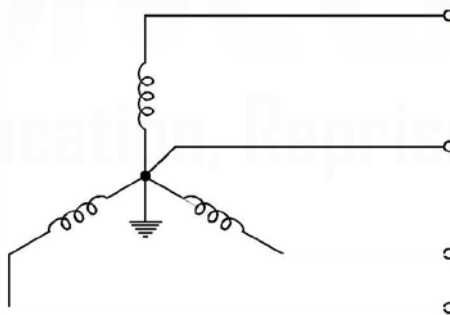

Fig. 10.7. Three Phase 4-Wire System.

The maximum voltage between one phase and grounded neutral is V volts.

$$V_{rms} = \frac{V}{\sqrt{2}}$$

\therefore Current per phase under balanced condition = $\frac{P}{3 \times \frac{V}{\sqrt{2}} \cos \phi}$

where ϕ is the power factor angle of load. If R_3 is the resistance per conductor, copper loss is given by

$$\text{Copper loss} = 3 \frac{2P^2}{9 V^2 \cos^2 \phi} R_3 = \frac{2}{3} \frac{P^2}{V^2 \cos^2 \phi} R_3$$

Equating the copper loss due to 3 phase 3-wires as calculated above with d.c. two wire system

$$\frac{P^2 R_1}{2V^2} = \frac{2P^2}{3 V^2 \cos^2 \phi} R_3$$

$$\text{or} \quad \frac{R_1}{R_3} = \frac{4}{3} \times \frac{1}{\cos^2 \phi} \quad \text{or} \quad \frac{a_3}{a_1} = \frac{4}{3} \frac{1}{\cos^2 \phi}$$

Since in case of three-phase three-wire system there are three wires and in case of d.c. two-wire system there are two wires, the volumes required for the same length l , are $3a_3 l$ and $2a_1 l$ respectively

$$\frac{3a_3 l}{2a_1 l} = \frac{3}{2} \frac{a_3}{a_1} = \frac{3}{2} \frac{4}{3} \frac{1}{\cos^2 \theta}$$

In case the fourth wire, in case of 3-phase, 4-wire system is of the same size as the phase wires, the volume of copper required will be $4a_3 l$ and the ratio

$$\frac{4a_3 l}{2a_1 l} = \frac{2a_3}{a_1} = 2 \frac{4}{3} \frac{1}{\cos^2 \theta} = \frac{8}{3} \frac{1}{\cos^2 \theta}$$

Similarly, to compare the volume of copper required in case of a.c. single phase two wire system with the d.c. two-wire system we equate copper losses

$$\frac{P^2}{2V^2} R_1 = \frac{P^2}{V^2 \cos^2 \phi} R_2$$

$$\text{or} \quad \frac{R_1}{R_2} = \frac{2}{\cos^2 \phi} \quad \text{or} \quad \frac{a_2}{a_1} = \frac{2}{\cos^2 \phi}$$

Since the number of wires required is two in each case the ratio of copper volume is

$$1 : \frac{2}{\cos^2 \phi}$$

Therefore, the ratio of copper volume required in the three cases under study when d.c. two wire system is taken as reference are

$$1 : \frac{2}{\cos^2 \phi} : \frac{8}{3} \frac{1}{\cos^2 \phi}$$

In case the system is single phase two wire with neutral grounded the reader will find that the ratio of volume of copper with reference to d.c. two wire will be

$$1 : \frac{8}{\cos^2 \phi}$$

Example 10.1. A d.c. two-wire system is to be converted into a.c. 3-phase 3-wire system by the addition of a third conductor of the same cross-section as the existing conductors. If the rms voltage between wires and the percentage loss in the line remains unchanged, determine the additional load which can now be supplied. Assume balanced load of unity p.f.

Solution. (a) d.c. two-wire : Let the power transmitted in this case be P and V be the voltage between wires

$$I = \frac{P}{V}$$

Therefore
$$\text{Loss} = \frac{2P^2}{V^2} R$$

where R is the resistance of each wire

Therefore,

$$\text{Per unit loss} = \frac{2P}{V^2} R$$

(b) 3-phase 3-wire : The r.m.s. voltage = V volts.

Let P' be the power transmitted then $I' = \frac{P'}{\sqrt{3}V}$ for unity p.f.

Therefore,

$$\text{Copper loss} = 3 \left(\frac{P'}{\sqrt{3}V} \right)^2 R = \frac{P'^2}{V^2} R$$

Therefore
$$\text{per unit loss} = \frac{P'}{V^2} R$$

Equating the per unit loss we have

$$\frac{2P}{V^2} R = \frac{P'}{V^2} R \quad \text{or} \quad P' = 2P$$

This shows that 100% additional power can be supplied by 3-phase 3-wire system.

10.4 POWER FACTOR IMPROVEMENT

Power factor of a circuit or installation is defined as the ratio of power consumed by the circuit (in watts or kW or MW) to the total complex power input to the circuit or the installation and is denoted by $\cos\phi$ where ϕ is the power factor angle and is the angle between the circuit voltage and current through the circuit. Consider Fig. 10.8 (a) where the current lags

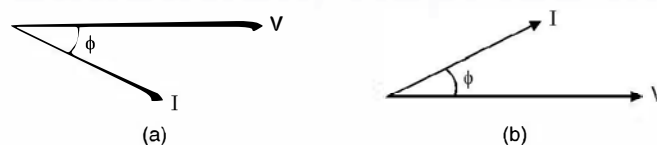

Fig. 10.8. Phasor diagram (a) Lagging (b) Leading.

the voltage by an angle ϕ whereas in (b) it leads the voltage by an angle ϕ . The active power consumed in both the circuit is $|V| |I| \cos\phi$ and the complex power is $|V| |I|$. The units are watts and volt-amperes respectively. However, the reactive power in (a) is being absorbed by the circuit as it is an inductive circuit whereas in (b) the reactive power is being supplied (lagging) or leading reactive power is taken from the supply due to the presence of capacitor in circuit (b) The p.f. in a circuit is decided by what the net reactive power is present in the circuit. So we first

study the sources and sinks of reactive power. In brief the inductance wherever it be, whether the winding of a generator or a motor or the series inductance of a line or a simple coil absorb (sink) the reactive power whereas the capacitance of a line or static capacitor or synchronous motor when overexcited acts as a synchronous capacitor.

In a circuit if both the inductor and capacitor are present, the reactive power due to inductor (phasor) is in phase opposition to the reactive power due to capacitor. The net reactive power will decide whether the circuit as a whole is inductive or capacitive. However, if the two reactive powers are equal in the circuit, the net reactive power requirement of the circuit is zero and hence the p.f. of the circuit is unity. The three possible situations are shown in Fig. 10.9. Conventionally, the reactive power due to inductor is taken as positive and that due to capacitor as negative. This is because the reactive power supplied by the source is taken as positive and that supplied by the load to the source is taken as negative. This convention is used in Fig. 10.9.

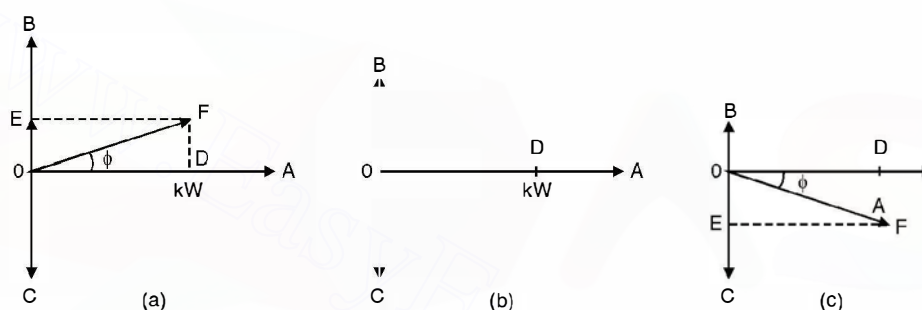

Fig. 10.9. Effect of reactive power on p.f.

In Fig. 10.9 (a) the inductive reactive power is greater than the capacitive and hence $OB - OC (BE) = OE$ is the net positive reactive power and OF the complex power in KVA and hence p.f.

$$\cos \phi = \frac{OD}{OF} \text{ lagging}$$

In Fig. 10.9 (b) since $OB = OC$ hence the net reactive power is zero and the p.f. of the circuit is unity *i.e.* the circuit behaves as resistive. In Fig. 10.9 (c) $OC > OB$, hence the net capacitive

reactive power is $OE = OC - OB (CE)$ and the power factor is $\cos \phi = \frac{OD}{OF}$ lead. Reactive power in

a circuit is defined as the wattless component of the complex power *i.e.* the component which does not do any effective work yet it is required in most of the electrical equipments and is sort of necessary evil just as friction is a necessary evil in our daily life activities. Reactive power is the time rate of change of electromagnetic energy stored in an inductor or the electrostatic energy stored in a capacitor. The presence of reactive power not only affects the p.f. of the circuit, it also affects the voltage levels at different points of the circuit. It is found that in a circuit if reactive power generated is more than the reactive power absorbed by the circuit, the voltage levels rise and voltage levels dip otherwise.

In an electric power system it is difficult to predict the load variation accurately. The load devices may vary from a few watt night lamps to multi megawatt induction motors. The following categories of loads are present in a system.

(i) Motor devices	70%
(ii) Heating and lighting equipment	25%
(iii) Electronic equipment	5%

10.4.1 Causes of Low p.f.

Among the chief causes of poor p.f. may be mentioned, induction motors (which form almost 70% of the total load) particularly in small sizes (fractional hp motors) and large motors when running partially loaded, arc and induction furnaces, electric discharge lamps (associated with ballasts) and transformers. The transformers are also predominantly inductive circuits and in fact each megawatt generated, transmitted and distributed requires an equivalent of 3 to 4 MVA capacity transformer, at different voltage levels.

10.4.2 Methods to Improve p.f.

Following methods can be used for improvement of p.f. of a circuit.

- (i) Use of high p.f. machines
 - (ii) Use of static capacitors
 - (iii) Use of synchronous capacitors.
- (i) **Use of high p.f. machines.** There are several types of especially designed motors which operate at a high p.f. of approximately unity (between 0.95 to 0.97 pf) notably the synchronous motor and the compensated induction motors. In general, it is found that such motors are more expensive and have a higher maintenance cost than the plain induction motors, so that in choosing such motors these additional costs must be balanced against the savings in energy cost due to their higher p.f. Of the above types, the synchronous motor is particularly useful as it can be very easily designed to operate at a leading p.f. and, therefore, compensate for the lagging p.f. of other machines.
- (ii) **Use of static capacitor.** Consider Fig. 10.10 where load (inductive) is connected to the source.

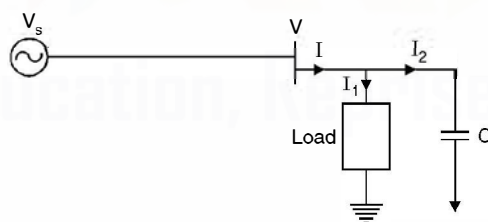

Fig. 10.10. Use of Static Capacitor.

For improvement of p.f. or improvement of voltage profile it is always desirable to connect a capacitor across the inductive load as shown in Fig. 10.10. As explained in article 7.7, a capacitor takes leading vars or it is equivalent to saying that it supplies lagging vars. Consider the phasor diagram in Fig. 10.11.

In Fig. 10.11 (a) the phasor diagram represents the kW, kVAr and kVA without the capacitor where the p.f. angle is ϕ and p.f. $\cos \phi$.

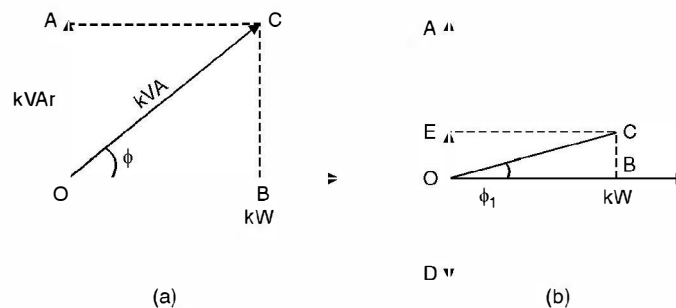

Fig. 10.11. p.f. improvement using static capacitor.

In Fig. 10.11 (b) when a capacitor C is connected across the load, it takes leading VARs or supplies the lagging VARs to the load and hence, the net lagging VARs to be supplied by the source are reduced by an amount OD and the source has to supply kVARs equivalent to $OA - OD = EO$ and the p.f. of the busbar improves to $\cos \phi_1$ as $\phi_1 < \phi$. It is to be noted very carefully that the p.f. of the load does not change here, it is a fixed quantity but it is the p.f. of the system which is improved with the use of a suitable value of capacitor across the load.

(iii) **Use of synchronous capacitor.** This has already been discussed at length in Article 7.7. The readers are advised to go through this article.

However, it may be mentioned here that to improve the p.f. above 0.95 requires a large amount of leading kVAr and the cost of the equipment to improve it to such high values may well out weigh any savings in energy costs.

Example 10.2. A slow speed alternator works in parallel with a turbo-alternator, the combined output being 2500 kW at 0.8 p.f. lag. If the turbo alternator provides 1000 kW at unity p.f., at what p.f. will the slow speed machine work ?

Solution. Total active power of the two alternators 2500 kW

Total reactive power $2500 \tan \cos^{-1} 0.8$

$$= 2500 \times 0.75$$

$$= 1875 \text{ kVAr}$$

Active power supplied by turbo alternator 1000 kW

Reactive power supplied by turbo alternator = zero

Hence active power supplied by the slow speed alternator = $2500 - 1000 = 1500$ kW

And reactive power supplied by the slow speed alternator = 1875 kVAr

Hence p.f. of the slow speed alternator $\cos \tan^{-1} \frac{1875}{1500} = 0.624$ **Ans.**

Example 10.3. Two alternators working in parallel supply a lighting load of 3000 kW and a motor load aggregating 5000 kW at a p.f. of 0.71. One machine is loaded to 5000 kW at p.f. 0.8 lag. Determine the load and p.f. of the other machine.

Solution. Total load active power requirement

Lighting load 3000 kW

Motor load 5000 kW

	8000 kW
--	---------

Total reactive power requirement of the load

$$\begin{aligned} \text{Lighting load} &= \text{zero} \\ \text{Motor load} &= 5000 \times \tan \cos^{-1} 0.71 \\ &= 5000 \times 0.9918 \\ &= 4959 \text{ kVAr} \end{aligned}$$

$$\begin{aligned} \text{Active power supplied by one machine} &= 5000 \text{ kW} \\ \text{Reactive power supplied by one machine} &= 5000 \tan \cos^{-1} 0.8 \\ &= 5000 \times \frac{3}{4} \\ &= 3750 \text{ kVAr.} \end{aligned}$$

Active power supplied by the other machine = $8000 - 5000 = 3000 \text{ kW}$

Reactive power supplied by the other machine = $4959 - 3750 = 1209 \text{ KVAr}$

$$\begin{aligned} \text{p.f. of the other machine} \cos \tan^{-1} \frac{1209}{3000} &= 1209 \text{ kVAr} \\ &= 0.927 \quad \text{Ans.} \end{aligned}$$

Example 10.4. A single phase motor takes a current of 40A at p.f. 0.7 lag from a 440 V 3-phase 50 Hz supply. Determine the value of a shunt capacitor so as to raise the p.f. to 0.9 lag, the load remaining the same.

Solution. The power active taken by the motor

$$\frac{440}{\sqrt{3}} \times 40 \times 0.7 = 7112 \text{ watt}$$

$$\begin{aligned} \text{and} \quad \text{reactive power} &= \frac{440}{\sqrt{3}} \times 40 \sin \cos^{-1} 0.7 \\ &= 254 \times 40 \times 0.714 \\ &= 7254 \text{ VAr.} \end{aligned}$$

The new p.f. is 0.9 lag, power remaining same reactive power requirement for this p.f.

$$7112 \tan \cos^{-1} 0.9 = 3444 \text{ VAr}$$

The VAr to be supplied by the shunt capacitor are $7254 - 3444 = 3810 \text{ VAr}$

The value of capacitor is given by

$$V^2 \omega c = 254^2 \times 314 c = 3810$$

$$\text{or} \quad c = \frac{3810}{254^2 \times 314} = 188 \mu\text{F} \quad \text{Ans.}$$

Example 10.5. A 500 W discharge lamp takes a current of 4A at unity p.f. Calculate the inductance of a choke required to enable the lamp to work on 250 V 50 Hz mains. Determine also the capacitance to be connected across the mains to bring the resultant p.f. to unity.

Solution. Since the lamp takes 4A at unity p.f. the supply voltage should be $\frac{500}{4} = 125$ volts.

However we want to connect, the same lamp across 250 volt. The circuit is as follows

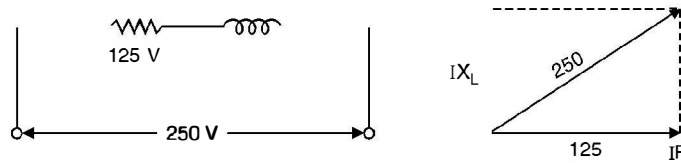

From the phasor diagram, the voltage across the choke would be

$$\sqrt{250^2 - 125^2} = 216.5 \text{ volt}$$

$$\text{The reactance of the choke} = \frac{216.5}{4} = 54.12$$

$$\omega L = 54.12$$

$$314 L = 54.12. \quad \text{Hence } L = 0.172 \text{ H}$$

The reactive power requirement of the choke $I^2 \omega L = 16 \times 0.172 w$

and if C is the capacitance required across the supply, the reactive power supplied by the capacitor is

$$V^2 \omega C = 250^2 \omega C = 16 \times 0.172 w$$

$$\text{or } 250^2 C = 16 \times 0.172$$

$$\text{or } C = 44 \mu\text{F}. \quad \text{Ans.}$$

10.5 GENERATION—NON-CONVENTIONAL SOURCES

The contemporary non-conventional sources of energy like wind, tidal, solar etc. were the conventional sources until James Watt invented the steam engine in the eighteenth century. In fact, the New World was explored by man using wind-powered ships only. The non-conventional sources are available free of cost, are pollution-free and inexhaustible. Man has used these sources for many centuries in propelling ships, driving windmills for grinding corn and pumping water, etc. Because of the poor technologies then existing, the cost of harnessing energy from these sources was quite high. Also because of uncertainty of period of availability and the difficulty of transporting this form of energy, to the place of its use are some of the factors which came in the way of its adoption or development. The use of fossil fuels and nuclear energy replaced totally the non-conventional methods because of inherent advantages of transportation and certainty of availability; however these have polluted the atmosphere to a great extent. In fact, it is feared that nuclear energy may prove to be quite hazardous in case it is not properly controlled.

In 1973 the Arab nations placed an embargo on petroleum. People began to realise that the fossil fuels are not going to last longer and that remaining reserves should be conserved for the petro-chemical industry. But unfortunately, both nuclear and coal energy pose serious environmental problems. The combustion of coal may upset the planet's heat balance. The production of carbon dioxide and sulphur dioxide may adversely affect the ability of the planet to produce food for its people. Coal is also a valuable petro-chemical and from long term point of view it is undesirable to burn coal for generation of electricity. The major difficulty with nuclear energy is waste disposal and accidental leakage (e.g. leakage at Chernobyl nuclear power plant).

As a result of these problems, it was decided by almost all the countries to develop and harness the non-conventional sources of energy, even though they are relatively costlier as compared to fossil-fuel sources. It is hoped that with advancement in technology and more and more research in the field of development of non-conventional sources of energy, these sources may prove to be cost-effective as well. The future of wind, solar, tidal and other energy sources is bright and these will play an important role in the world energy scenario.

The following sections have been devoted to the study of some of the important non-conventional sources of energy.

10.5.1 Tidal Power

Tidal or lunar energy as it is sometimes called, has been known to mankind since time immemorial. Various devices, particularly the mills were operated using tidal power. In the past water supply of London was pumped to a water tower by a mill operated by the tidal power (which consisted of a large paddle wheel mounted on a raft and fastened between two of the piers of old London Bridge). The tidal power has been used to irrigate fields in Germany and to saw firewood in Canada.

Tides are caused by the combined gravitational forces of Sun and Moon on the waters of the revolving Earth. When the gravitational forces due to the Sun and the Moon add together, tides of maximum range, called spring tides, are obtained. On the other hand, when the two forces oppose each other, tides of minimum range, called neap tides, are obtained. In one year there are approximately 705 full tidal cycles.

Even though many problems have to be overcome in tidal power development, this form of power has certain definite advantages. Output of a tidal power station is independent of the seasonal changes and can be predicted well in advance, as it depends on the cosmic phenomenon. It is possible to predict the amount of power and the time at which it will be available throughout the year. This power can, therefore, be utilized at the proper position of the load curve.

More than fifty sites have been identified in the world for possible generation of tidal power. As more and more technological advancement take place, even more sites could be identified for tidal power development. Some of the important sites are :

(i) La Rance (France), (ii) Severn Barrage (UK), (iii) White Sea (USSR), (iv) Passamaquoddy (USA), (v) Gulf of Cambey (India) and (vi) Gulf of Kutch (India).

The maximum tidal range in the Gulf of Cambey is about 10.8 m and is quite attractive for a tidal plant. However, the silt charge of the Gulf of Cambey is relatively high and needs a closer study for further development.

The Gulf of Kutch has a maximum spring tide of 7.5 m and the silt charge is relatively low.

10.5.2 Wind Power

The wind wheel, like the water wheel, has been used by man for a long time for grinding corn and pumping water. Ancient seamen used wind power to sail their ships. With the development of the fossil fuelled and hydro-electric plants, there was decline in the use of wind power due to the less cost involved in the new methods. Another difficulty with wind power was the problem of energy storage. The energy could not be made available, on demands, due to uncertainties of wind. Due to these two reasons, no further attempt was made to develop wind power for large scale power generation.

In recent years, however, as a result of energy crisis in the world, it has been decided to investigate all possible means of developing power, as alternatives to fuel fired plants. The wind could supply a significant portion of the world's energy demand. An estimate by an American Professor indicates the potentialities of wind power. According to him about 350,000 wind mills each rated for about 1250 KW to 2200 KW could develop power of the order of 190,000 MW. With the advancement in the knowledge of aero-dynamics it has been possible to build larger and more efficient wind power plants. A typical example is the 1250 KW installation at Grandpa's Knol in U.S.A. Whereas some success has been achieved in developing small and medium size plants, the prospects of large scale generation *i.e.* 1 MW or above are not, as yet very encouraging.

Economic development of wind power requires selection of sites where high specific outputs are compatible with reasonable cost of construction of plant. It is, therefore, necessary to obtain wind velocity duration curve for a particular site and to know the output of the machine for varying wind velocities. The maximum efficiency of the wind power plant is found not to exceed 40%.

The wind power plants can be operated in combination with steam or hydro power station, which will lead to saving in fuel and increase in firm capacity, respectively of these plants.

Wind energy can prove to be a potential source of energy for solving the energy problem. It can certainly go a long way to supply pollution-free energy to millions of people, living in the villages all over the world.

The economic viability of wind mills is better in situations where conventional transmission costs are extremely high (because of inaccessibility and small load) or where continuous availability of supply is not essential so that only a limited amount of storage or standby power need be provided.

10.5.3 Geothermal Power

Many geothermal power plants are operating throughout the world. Although larger geothermal power plants are in operation in America today, it is to the credit of the Italians that the first impressive breakthrough in geothermal power exploitation was achieved. The oldest geothermal power station is near Larderello in Italy, which has an installed capacity of 380 MW. In New Zealand geothermal power accounts for 40% of the total installed capacity, whereas in Italy it accounts for 6%.

It is a common knowledge that the earth's interior is made of a hot fluid called 'magma'. The outer crust of the earth has an average thickness of 32 Km and below that, is the magma. The average increase in temperature with depth of the earth is 1°C for every 35 to 40 metre depth. At a depth of 3 to 4 Kms, water boils up and at a depth of about 15 Kms, the temperature is, in the range of 1000° to 1200°C. If the magma finds its way through the weak spots of the earth's crust, it results into a volcano. At times, due to certain reasons the surface water penetrates into the crust, where it turns into steam, due to intense heat, and comes out in the form of springs or geysers. Moreover, the molten magma also contains water, which it releases in the form of steam, which could be utilized for electric power generation.

Combined Operation of Geothermal Plant

It is well known that a composite power system can be supplied more economically by a combination of two main types of plants :

- (i) Base Load Plant which is characterised by high fixed cost and low variable cost.

(ii) Peak Load Plant which is characterised by low fixed cost and high variable cost.

In case of a geothermal plant, the usual practice is to regard all the production cost as fixed cost, with zero variable cost as no fuel is required for its operation. This is justified by the fact, that once geothermal steam has been made available by means of capital spent on exploitation, drilling and pipe work, it may be regarded as free. Geothermal plants are, therefore, ideally rated as base load plants. Most of the plants today are being used as base load plants as they can achieve annual plant load factor of 90% or more—higher than that obtainable from thermal or nuclear plant.

The commercial viability of geothermal power plant as compared to other sources, depends upon the cost of alternative power sources and other local factors. As a rule of thumb, the following guidelines may be followed to assess its viability :

- (i) The fluid temperature at the bottom of the bore should be at least 180°C.
- (ii) A temperature of 180°C should be available at depths not exceeding 3 Kms.
- (iii) The yield from a $24\frac{1}{2}$ cm bore should be a least 20 tons/hr of steam.

The following are some of the geothermal power projects in operation :

Larderello	:	Italy
Geysers	:	California (USA)
Cerro Prieto	:	Mexico
Hatchobaru	:	Japan
Matsukawa	:	Japan
Paratunka	:	USSR
Wairakei	:	New Zealand
Pugga Multipurpose Project (Ladakh)	:	India

At present geothermal energy makes a very small, but locally important, contribution to world energy requirements. This situation will not change unless important technological advances are made. Environmentally, it is probably the least objectionable form of power generation available at present, with, the exception of hydroelectric methods.

10.5.4 Wave Power

Another source of non-conventional energy generation is the wave power. The major problem with the wave power is that it is not concentrated at a place. If means could be developed for collecting the energy in the wave, spread over a large surface area, and concentrating it into a relatively small volume, the prospects, would be considerably improved.

It has been observed that a typical wave measures 2 to 3 metres in height throughout the year. The energy per square metre of wave surface area is given as $\frac{1}{2}\rho g a^2$ where ρ is density of sea water, g is acceleration due to gravity and a is the amplitude of the wave. In the Atlantic, the wave period T is around 9 s, and the average velocity of propagation of wave is 14 m/s. It has been observed that a power flow of around 70 KW for every metre of wave front, can be obtained. This is a considerable amount of power, especially when we think of the availability of this power throughout the year. If the length of the coast line is, say 1200 Km, the power available is around 84 GW.

10.5.5 Magneto Hydro Dynamic (MHD) Generation

In the conventional steam power plants, the heat released by combustion of fuel is transformed into the internal energy of steam. The temperature and pressure of steam increase in the process. The steam turbine, then, converts steam energy into mechanical energy, which drives a generator. This way, the mechanical energy is converted into electric energy. The repeated conversion of various forms of energy involves losses and, hence, the overall efficiency of thermal power plant decreases. The typical range of efficiency of thermal plants is 37 to 40%. The direct conversion of heat to electricity would enable the industry to use the fuel resources more efficiently. MHD generation is one form of energy technology, wherein direct conversion of heat into electric energy has been devised. The technological development in the field of plasma physics and metallurgy etc. and other branches of science and technology has made it possible for this kind of direct transformation of energy.

An ionized gas is used as conducting medium in the MHD generator. The gas can be made electrically conducting when it is maintained at least at a temperature of 2000°C . This fact does not allow MHD generation from being used in the entire temperature range from 3000 K to 300 K. It is, therefore, thought beneficial that MHD generators be used in conjunction with steam operated thermal plants utilising the heat of the gas leaving the MHD ducts. The combined operation of MHD generators alongwith the conventional thermal plant, will raise the overall efficiency to nearly 60%, thereby lot of saving in the fuel cost will result.

Principle of Operation of MHD Generator

The basic principle of operation is based on Faraday's law of electro magnetic induction, which states an e.m.f. is induced in a conductor moving in magnetic field. The conductor may be a solid, liquid or a gaseous one. The study of the dynamics of an electrically conducting fluid interacting with a magnetic field, is called magneto hydro dynamics.

In this method (Fig. 10.12) gases at about 2500°C are passed through the MHD duct across which a strong magnetic field has been applied. Since the gases are hot, and partly ionized they form an electrically conducting conductor moving in the magnetic field. An e.m.f. (direct-current) is thus induced, which can be collected at suitable electrodes.

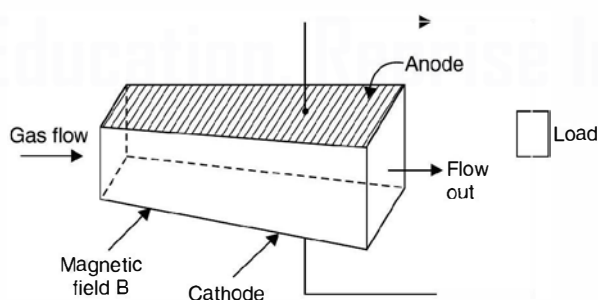

Fig. 10.12. Basic Principle of MHD Generator.

10.5.6 Solar Energy

Sun is the primary source of energy. The earth receives 1.6×10^{18} units of energy from the Sun annually, which is 20,000 times the requirement of mankind on the earth. Some of the solar energy causes evaporation of water, leading to rains and creation of rivers etc. Some of it is

utilized in photosynthesis which is essential for sustenance of life on earth. Man has tried, from time immemorial, to harness this infinite source of energy, but has been able to tap only a negligibly small fraction of this energy, till today.

Three broad categories of possible large scale applications of solar power are :

- (i) The heating and cooling of residential and commercial buildings;
- (ii) The chemical and biological conversion of organic material to liquid, solid and gaseous fuels; and
- (iii) Conversion of solar energy to electricity.

The use of solar energy for generation of electricity is costly as compared to conventional methods. However, due to scarcity of fuel, solar energy will certainly find a place in planning the national energy resources.

10.6 CONVENTIONAL SOURCES

10.6.1 Hydro Station

The water wheel, as developed in the early part of 19th century, played an important role in converting water power into mechanical power. With the invention of steam engines, the use of water wheel began to decrease and larger steam engines were developed. Steam engines possessed the advantage of mobility, allowing power to be produced, where it was required and also that of flexibility in its application.

It was only later with the discovery of conversion of mechanical energy into electric energy, and transmission of electric energy being the most efficient method of transporting energy from one place to another, that water wheel was revived. The modern water turbine, is being built in single unit of more than 200 MW. Also, the concept of multipurpose project, in which the production of power is included as one of several uses (flood control, navigation, irrigation, water for domestic and industrial purpose, etc.), has led to the development of sites which otherwise could not be harnessed economically for power alone. The capital investment per KW is much higher in case of hydro power as compared to thermal power. This is because in order to store water at sufficient head, it is essential to construct a dam which is a costly affair. However, the running cost of hydro electric energy is much less as no fuel is used.

Water power differs fundamentally from thermal power in that it represents an inexhaustible source of energy which is continually replenished by the direct agency of the Sun; whereas thermal power represents chemical energy which has been created and stored within the earth's crust during past geological ages. The use of chemical energy is thus equivalent to the consumption of capital as the replacement is not so easy. Another important difference between the two is that whereas water power can be developed only where it is present in nature, thermal power (liquid or solid fuel) can be transported for use from one place to another.

Classification of Hydro Plants

The hydro-power plants can be classified in terms of location and topographical features, the presence or absence of storage, the range of the operating head etc.

Classification based on Plant Capacity

- | | | |
|----------------------------|---|--------------------|
| (i) Micro hydel plant | : | less than 5 MW |
| (ii) Medium capacity plant | : | 5 to 100 MW |
| (iii) High capacity plant | : | 101 MW to 1000 MW. |
| (iv) Super capacity plant | : | above 1000 MW |

10.6.2 Steam Power Plant

With the invention of steam engine for obtaining mechanical energy, the so-called non-conventional methods i.e. wind, tidal, geothermal etc. were abandoned as the cost involved was high and also there was no flexibility for transportation of this form of energy. The development of steam turbines and then electric generator completely replaced the non-conventional methods. Fossil fuels became the main source of energy for quite sometime. The size of the thermal plants grew from a few KW to more than 1000 MW as of today. The concept of generating electrical energy using fossil fuel has changed completely, the concept of locating the power plants near the load centres to locating near the fuel pithead. Super-thermal power plants (plants with capacity 1000 MW or more) have come into existence. It has been found more economical in general to generate electrical energy near the pithead rather than near the load centres, even though the energy has to be transported over the transmission lines, which involves a large percentage of total capital cost and transmission line losses. On the other hand by installing a plant near pithead saves the cost of transporting the coal etc. A 400 MW capacity plant requires about 5000 to 6000 tons of coal every day.

10.6.3 Nuclear Power Plants

Nuclear power industry has made relatively faster growth as compared with other forms of power industries. The first power reactor was commissioned sometime in 1944 and by 1972 there were more than 100 nuclear power plants in the world, with the total capacity exceeding 30 GW. The rapid growth can be associated with the following characteristics of the materials used for nuclear power generation :

- (i) Energy is released without using oxygen for combustion (fission).
- (ii) Breeding of nuclear fuel is possible so that we produce almost same amount of nuclear fuel as is spent, without reduction of power output.
- (iii) The weight of fuel required for generating a particular amount of energy is much less than what is required in conventional methods of generation.

Nuclear Fuel

Uranium is the fuel used in nuclear power plants. It is non-renewable and has two isotopes, U-235 about 0.7% and U-238, 99.3%. Materials fissionable by thermal or low speed neutrons are U-233, U-235 and Pu-239 (plutonium).

As natural Uranium is available in abundance in Britain, most of the reactors are using natural Uranium, whereas United States of America are using enriched Uranium for most of their reactors. In India, Rajasthan Atomic Power Plant uses natural Uranium, whereas Tarapur Power Plant uses enriched Uranium. If natural Uranium is used, the size of the plant is larger than when enriched uranium is used. It has been estimated that about 1.2 kg of Uranium produces 1 MW of power for one year.

10.6.4 The Gas Turbine Plant

The first gas turbine was used in 1939 for large central station service as a prime mover. Since then several stations have been in operation. These plants require less space for the same capacity as compared to a steam plant, it provides more flexibility in design, and involves low initial cost.

Air is used as the working fluid. It is compressed by the compressor and fed to the combustion chamber where it is heated by burning fuel in the chamber or by air heaters. The hot air at high pressure, moves from the combustion chamber to the gas turbine where it expands and delivers mechanical energy. The gas turbine drives the alternator which converts mechanical energy into electrical energy. The compressor, the gas turbine and the alternator are mounted on the same shaft so that a part of turbine power is supplied to the compressor besides the alternator. Therefore, the efficiency of the gas plant is relatively low (about 20%).

Comparison of Salient Features of Various Types of Power Plants

<i>S.No.</i>	<i>Particulars</i>	<i>Hydro plant</i>	<i>Steam plant</i>	<i>Nuclear plant</i>	<i>Gas plant</i>
1.	Site	Large quantities of water at sufficient head. Feasibility of constructing economical dam.	Normally located near the load centre. Superthermal Power Plants at the coal pit head.	Normally located near the load centre, away from the thickly populated areas to avoid radioactive pollution.	Can be installed anywhere.
2.	Initial cost	Highest because of civil works	Low	In between Hydro and Steam	Lowest
3.	Running cost	Lowest	In between hydro and nuclear	Highest	Lower than nuclear
4.	Maintenance Cost	Lowest	In between hydro and nuclear	Highest	Lower than steam and nuclear
5.	Transmission and Distribution cost	Highest	Low	Lower	Lowest
6.	Simplicity and cleanliness	Simple and clean	Causes air pollution	Equipment handling complex, leakage may lead to disastrous air pollution.	Simpler and cleaner than steam.
7.	Overall efficiency	Most efficient, approx, 85%	Least efficient. Overall approx. 25%	Quite efficient approx. 30%	More than diesel, approx. 40%
8.	Starting	Instant starting	Max. time (about 1/2 hr.)	Time less than for steam plant.	About 2 min.
9.	Space requirements.	Maximum	Less than that for Hydro	Least	Less than steam
10.	Field of application	Peak or base load	Base load	base load	Peak load or as standby unit.
11.	Reliability	Most reliable	Less reliable	Reliable	Reliable

PROBLEMS

- 10.1. Draw single line diagram of a power system. Label all the major components of the system.
- 10.2. Discuss the advantages of ring main distribution system over the radial system.
- 10.3. Compare a 3-phase 4-wire system with the single phase system.
- 10.4. Describe briefly various supply systems in power system.
- 10.5. What are the causes of low p.f. in power system and discuss various methods of improving the power factor.
- 10.6. Compare the performance of static capacitor with a synchronous condenser as a p.f. improvement device.
- 10.7. A synchronous generator supplying 2000 kW operates in parallel with an induction generator supplying 1000 kW. The load has a lagging p.f. of 0.8. The induction generator has a p.f. of 0.95. Determine the p.f. at which the synchronous machine is working. [Ans. 0.612]
- 10.8. A synchronous motor overexcited to take 600 kVA gives 360 hp at an efficiency of 0.9. It runs in parallel with a load of 1000 kVA at p.f. 0.8 lag. Determine the resultant p.f. [Ans. 0.99 lag]
- 10.9. Briefly discuss various non-conventional methods of generating electrical energy.
- 10.10. "The non-conventional methods were known to man since time immemorial, still they were not developed". Comment and give reasons.
- 10.11. Explain why it is necessary to develop non-conventional methods of generating electrical energy.
- 10.12. Discuss the advantages of tidal power and name a few projects, harnessing tidal power.

CHAPTER

11

Domestic Wiring

11.1 INTRODUCTION

The practice of domestic wiring has been standardised. Any deviation for these practices may lead to untoward incident like short circuits or electric shock to personnel *e.g.* it is mandatory to place a fuse wire in the phase wire (live wire). An attempt to put it in the neutral may create problem after the fuse blows off due to short circuit. Proper material should be used for laying the domestic wiring depending upon the environment, location, safety to personnel, to equipments etc.

11.2 TYPES OF DOMESTIC WIRING

Following are the different types of domestic wiring :

1. Cleat wiring
2. Wooden casing and capping wiring
3. TRS or Batton wiring
4. Surface conduit wiring
5. Concealed conduit wiring

The above listing is in the direction of increasing cost ; temporary/permanent wiring and better appearance. We discuss them in brief as follows :

11.2.1 Cleat Wiring

In this system of wiring the cables are gripped and supported between cleat made of porcelain. These cleats are made in two halves; the lower part is grooved to accommodate, the cable and the upper part is put over it. After the cable is put-between the cleats, these are then screwed on wooden plugs also known as gutties. The gutties should first be fixed into the wall at regular intervals of about 50 cm. The screws used are of size 38 mm length. For 250 volts supply, the cables will be placed 2.5 cm apart centre to centre for single core cables. Only one cable is passed through each groove of the cleat. While screwing too much pressure should not be applied so that its insulation remains intact. The cables normally used in cleat wiring are VIR (Vulcanised India rubber) cable, PVC cables etc. In this system of wiring sharp bends and undue twisting should be avoided. Also, whenever cable has to pass through walls, floors or any other concealed location, the conduit pipe of suitable length should be used for that portion of wiring. Cleats for two wires are shown in Fig. 11.1.

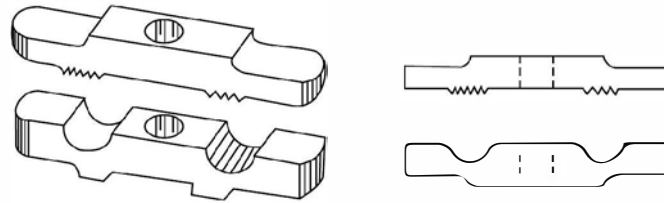

Fig. 11.1 Cleats for two wires.

The advantages and disadvantages of cleat wiring are:

Advantages :

1. The installation and dismantling is simple and fast and hence is very useful for temporary wiring.
2. The cable can be inspected easily and if there is any problem with the wiring the same can be rectified without much problem.

Disadvantages :

1. The appearance of the wiring is not good.
2. It cannot be used in damp places.
3. As the wiring is exposed to atmosphere, its life span is short.

11.2.2 Wooden/PVC Casing and Capping Wiring

This method of wiring is one of the very old method and is in use even as of now. This system is suitable for the voltages installations using VIR or PVC cables.

The Casing and Capping form two parts of the wooden or PVC, the Casing and Capping have grooves. The cable is placed in the grooves of the Casing and this is then covered by capping as shown in Fig. 11.2. The Capping is fitted to the casing with the help of screws of 12.7 mm length. The Casing and Capping should be made of teak wood.

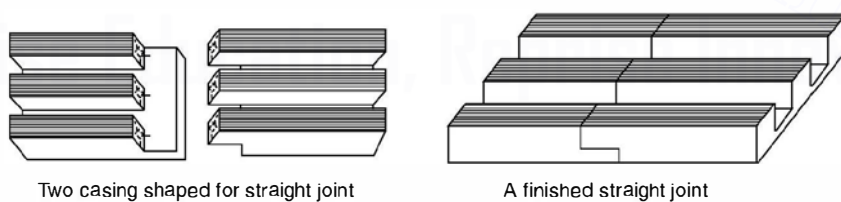

Fig. 11.2 Two casing shaped for straight joint.

The casing should be spaced from the wall by means of small porcelain blocks or disc insulators not less than 6.5 mm thick so that direct contact to the wall is avoided and hence it is protected against dampness of wall.

The following are the advantages and disadvantages of this method of wiring.

Advantages :

1. It is relatively cheaper as compared to conduit but costlier as compared to cleat-wiring.

2. Short-circuit of wire *i.e.* between phase and neutral is avoided as the two are placed in different grooves.
3. Physical inspection of wiring makes it simple to carry out any repair if required (by opening the capping).
4. PVC casing capping gives better look and is economical as compared to wood.

Disadvantages :

1. In case of a short-circuit, there is risk of fire (use of wood or PVC).
2. Normally not recommended for damp places.

11.2.3 Toughened Rubber Sheath (TRS or CTS) or Batton Wiring

In this case the cables are carried on seasoned teak wood perfectly straight and well varnished teak wood batton of thickness not less than 1 cm. The cables are fixed on the batton by means of tinned brass or aluminium link clips already fixed on the batton with small nails before laying cables. The battons are fixed to the walls by means of gutties with countersink headed wooden screws. The screws are to be fixed on the batton at an interval of about 75 cms. The minimum width of batton is 13 mm for two wires. It is found suitable where acids and alkalies are stored. The various sizes of batton available are 13, 19, 25, 31, 38, 44 and 50 mm width. Depending upon the no. of cables to be run, a suitable size of batton should be used.

The main advantages and disadvantages of this wiring are :

1. Easy to instal and economical as compared to casing cappings or conduit wiring.
2. Easy to detect fault if any and has good appearance.
3. Relatively good life span.

Disadvantages :

1. Not suitable if exposed to sun and rain or places where dampness exists.
2. Risk of fire high.

CTS stands for Cab Type sheathed.

11.2.4 Conduit Wiring

There are three types of conduit wiring :

- (a) Concealed conduit wiring
- (b) Surface conduit wiring
- (c) Flexible conduit wiring.

Concealed conduit wiring. Here the conduits are embedded along the wall in plaster at the time of construction. The VIR or PVC cables are drawn into the conduits by means of GI wire of 18 SWG. The conduit should be electrically and mechanically continuous and connected to earth at some suitable places using earth wire. This method of conduit wiring is preferred for domestic over other methods as it maintains the beauty of the house and no projected pipes are visible.

Surface conduit wiring. As the name suggests the conduit is spaced from the wall by means of small wooden spacers below the conduits along its length at regular intervals. This system is commonly used in industrial wiring but is not recommended for domestic wiring as it spoils the beauty of the house. The usual size of the conduit is 25 mm diameter for domestic wiring.

Flexible conduit wiring. This method of wiring is used to provide mechanical protection to cables between rigid conduits (surface conduit) and electric machine or any other electrical device. However, this is not a general method of wiring. It is used for connecting rigid conduit with machine terminal box in case of motor wiring and energy meter with main switch in case of industrial and domestic wiring.

The following are the advantages and disadvantages of conduit wiring :

Advantages :

1. It provides protection against mechanical injury to insulated cables and against short-circuits.
2. Since conduits can be made water tight, the conduit wiring provides protection against moisture.
3. Gives better appearance.
4. Relatively longer life.

Disadvantages :

1. It is a relatively costlier system of wiring.
2. Highly skilled workmanship is required and it is more time consuming.

The method of wiring is normally recommended where cost is not the consideration *e.g.* in big hotels, workshops and factories and places of storing inflammable materials.

11.3 SPECIFICATIONS OF WIRES

Usually cables or wires have a no. of strands twisted together. Standard stranding consists of 6 wires around 1, then 12 around 6, followed by 18, 24 and so on. A stranded conductor is expressed as 7/0.1 where the first number stands for the no. of strands used and the second number corresponds to the diameter of each strand in mm. Some times the second number given corresponds to the gauge of the strand used *e.g.*, 3/20 which means a cable with three strands each of 20SWG.

All electric cables consist of three essential points :

- (a) the conductor for transmitting electrical power,
- (b) the insulation, an electrical insulating medium, needed to insulate the conductor from direct contact with earth or other objects, and
- (c) external protection against mechanical damage, chemical or electro-chemical attack, fire or any other dangerous effects external to the cable.

Copper conductor has extensively been used for cables but of late aluminium is being used to a considerable extent. To obtain flexibility a number of wires are made up into a strand which makes it easier to handle, less liable to kink and break and to a large extent eliminates risk to the conductor breaking through the dielectric. The wires in a stranded conductor are twisted together to form lays. The successive layers usually are stranded in opposite direction *i.e.*, if the wires of one layer have a right-handed lay, the next layer has a left-handed lay.

In regard to specification of cables, it is important to mention all possible details regarding the particular type of cable in terms of size (in mm or mm²) types of conductor whether copper or aluminium, type of insulation PVC or VIR and voltage grading.

11.3.1 Size of Conductor

Following points must be kept in mind while determining the size of the conductor for internal wiring for a given circuit.

- (i) Minimum size of the conductor for mechanical reason
- (ii) Current carrying capacity
- (iii) Voltage drop

Minimum size of Conductor

(i) **Wire.** The minimum size of copper conductor in use is 1/1.2 mm based on permissible wattage of 800 watts in the subcircuit. The aluminium conductor of size 1/1.4 mm is used for a subcircuit in domestic wiring and minimum size of conductor for power wiring is 4 mm² and 1/2.24 mm.

(ii) **Underground cables.** The area of cross section of conductor for two core cables should not be less than 6 mm² and for three and four core cables it should not be less than 25 mm². The minimum area of cross section of a three and half core cable should be 50 sq. cm.

Current-carrying capacity. When current is passed through a wire a certain amount of power is wasted in the wire which appears in the form of heat which results in increase in temperature of the conductor which may again decrease the life of insulation and, therefore, the rating should be such that when that current is allowed to flow continuously it does not affect the insulation of the cable. However, it should be able to carry a relatively larger current. (Varying between 1.5 to 2 times the continuous rated current.) for a short duration without affecting the insulation.

Voltage drop. Before deciding a proper size of cable to be used in a circuit, due consideration must be given to voltage drop. This voltage drop in the cable from distribution board to the point of device (lamp, fan, motor etc.) is due to the flow of current through the cable. The permissible voltage drop from supply terminal to any point on the wiring system should not exceed 2% + 1 volt for light loads and 7.5% for declared supply voltage of power loads.

We take a few examples to illustrate the selection of specification for wires:

Example 11.1. Determine the size of the conductor for power and lighting circuit from meter to main distribution board having three light/fan circuits of 800 watt each and two 15A circuits (power circuits) of 1500 watt each. Assume negligible voltage drop.

Solution. Load wattage in 5 A circuit = $3 \times 800 = 2400$ watts.

Load wattage in 15 A circuit = $2 \times 1500 = 3000$ watts.

Total load = 5400 watts.

Assuming an average p.f. of 0.8

Current in amperes at 230 volt supply.

$$\frac{5400}{230 \times 0.8} = 29.3 \text{ A} \approx 30 \text{ A}$$

Hence current under short circuit $30 \times 1.5 = 45 \text{ A}$

From the table 11.1, for aluminium wire the size of the conductor comes out to be 25 mm². In fact for 43 A it is 16 mm² but we should always go for one higher size of the conductor and hence we select conductor of size 25 mm² or 7/2.24 mm.

Table 11.1. Current Rating of Aluminium conductor Single core cables for VIR, PVC or Polythene insulated including tough rubber, PVC

Size of conductor		2 cables d.c. or single phase a.c.		3 or 4 cables or balanced three phase		Four cables d.c. or single phase a.c.	
Nominal area in Sq. mm	No. and diameter of wire in mm.	Current rating in Amperes	Approx. length of run for one volt. (M.)	Current rating in Amps.	Approx. run for one volt drop in (Mt.)	Current rating (amps.)	Approx. run for one volt drop in Mts.
1.5	1/1.40	10	2.3	9	2.9	9	2.5
2.5	1/1.80	15	2.5	12	3.6	11	3.4
4.0	1/2.24	20	2.9	17	3.9	15	4.4
6.0	1/2.80	27	3.4	24	4.3	21	4.3
10.0	1/3.55	34	4.3	31	5.4	27	5.4
16.0	7/1.70	43	5.4	38	7.0	35	6.8
25.0	7/2.24	59	6.8	54	8.5	48	8.5
35.0	7/2.50	69	7.2	62	9.3	55	9.0
50.0	[7/3.50 19/1.80	91	7.9	82	10.1	69	10.0
70.0		19/2.24	134	8.0	131	9.5	—
95.5	19/2.50	153	8.8	152	10.1	—	—

Example 11.2. A single phase supply is to be brought to a residence from the mains which is at a distance of 25 m. The supply is at 230 V and the current to be carried is 5 A, determine the size of the conductor.

Solution. Permissible voltage drop = 1 + 2% of 230 V
= 1 + 4.6 = 5.6 volts

Referring to the table for selection of wire of aluminium conductor, the min. size of wire is of 1.5 mm² section or 10 A and produces a voltage drop of 1V for using 2.3 metre length. Hence

voltage drop at 10A is $\frac{25}{2.3}$ volts

$$\begin{aligned} \text{Hence voltage drop at 5 A} &= \frac{25}{2.3} \times \frac{5}{10} \\ &= 5.4 \text{ volt} \end{aligned}$$

As the permissible drop is 5.6 volts and the conductor with 1.5 mm² section gives voltage drop of 5.4 volts hence the suitable size is 1/1.40 mm. **Ans.**

Example 11.3. Determine the size of the conductor to be used for wiring a 10 kW 400 V, 3-phase 50 Hz induction motor. The voltage drop is negligible between the main switch and the motor terminals.

Solution. Assuming efficiency of 85% and a p.f. of 0.8 the input current to the motor is

$$\frac{10 \times 1000}{\sqrt{3} \times 400 \times 0.8 \times 0.85} = 21.2 \text{ A}$$

At the time of starting the induction motor may take 2 times the rated current and hence starting current = $21.2 \times 2.0 = 42.4 \text{ A}$.

From the table corresponding to 42.4 A *i.e.* 43 A the wire used is 7/1.7 mm or 16 mm².

11.4 DISTRIBUTION BOARD

Fig. 11.3 shows a distribution board located in covered Verandah in a house or in the room where there is no Verandah. Care should be taken to see that privacy should not be disturbed while selecting the location for meter board as the meter reader shall be visiting the house regularly.

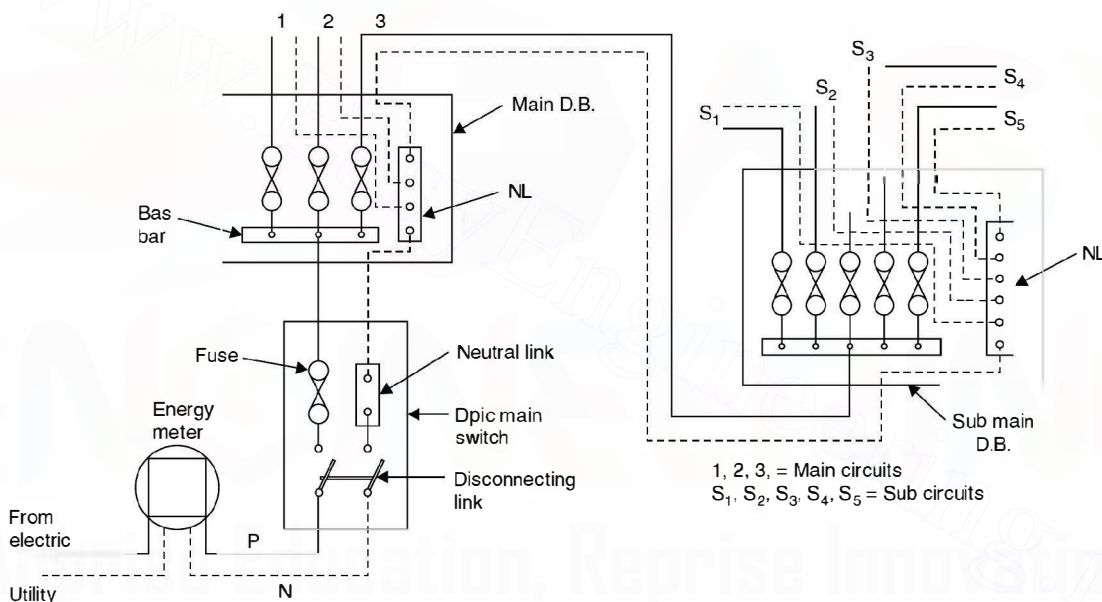

Fig. 11.3 Distribution Board.

The cable from the electric utility is connected to the energy meter first before taking it to any other connection. From the load terminals of energy meter it is taken to distribution through a double pole iron clad switch (DPIC). The phase wire is connected to a metal bar or bus bar of the main distribution board through a fuse, and neutral link of the DPIC switch is connected to neutral link of the main distribution board. From here the neutral wire is distributed one each with various phase wires to form a complete sub circuit. It is important to note that neutral wire is never looped from one circuit to the other.

11.5 TYPES OF CABLES

A brief description of the various cables used in domestic wiring is given here.

The main requirements of the insulating materials used for cable are :

1. High insulation resistance.
2. High dielectric strength.
3. Good mechanical properties *i.e.* tenacity and elasticity.
4. It should not be affected by chemicals around it.
5. It should be non-hygroscopic because the dielectric strength of any material goes very much down with moisture connect.

Vulcanized Rubber

Rubber in its natural form is highly insulating but it absorbs moisture readily and gets oxidized into a resinous material; thereby it loses insulating properties. When it is mixed with sulphur alongwith other carefully chosen ingredients and is subjected to a particular temperature it changes into vulcanized rubber which does not absorb moisture and has better insulating properties than even the pure rubber. It is elastic and resilient.

The electrical properties expected of rubber insulation are high break-down strength and high insulation resistance. In fact the insulation strength of the vulcanized rubber is so good that for lower voltages the radial thickness is limited due to mechanical consideration.

The physical properties expected of rubber insulation are that the cable should withstand normal hazards of installation and it should give trouble-free service.

Vulcanized rubber insulated cables are used for wiring of houses, building and factories for low power work.

PVC (Polyvinyl chloride) cables. These are thermoplastic insulating materials and not used for high temperature as it gets softened and flows down to heat. These are therefore, not used for heating appliances. PVC is harder than rubber, hence a thin layer of PVC insulation is good enough. In fact, its thickness is decided by mechanical reasons rather than electrical. The PVC insulated cables are lesser in diameter as compared to TRS and more number of wires can be placed in conduit as compared to TRS wires. These are used upto 1.1 kV voltages especially in concealed wiring system.

Tough Rubber Sheathed (TRS) or Cab Type Sheathed (CTS) Cables. This cable is used where humidity is high and it does not deteriorate even during long duration of exposure to moisture. As the name suggests these cables are provided with outer protective covering of tough rubber over normal insulation. These are available as single, twin and three cores with an earth continuity conductor. These are used on 250/500 volt circuits.

11.6 LIGHTING CONTROL CIRCUITS

Various lighting control circuits have been developed for maximum convenience and economical use of electric lighting.

Fig. 11.4 (a) shows a circuit diagram for switching two incandescent lamps with a single pole lighting switch. The no. of lamps in the circuit may be one, two or more. Fig. 11.4 (b) shows

a circuit diagram controlling several lamps with two lighting switches, the circuit having one plug socket at its end. Under all circumstances the plug socket must be independent of the operation of the general lighting units and it must be connected to the nearest point in the common supply circuit.

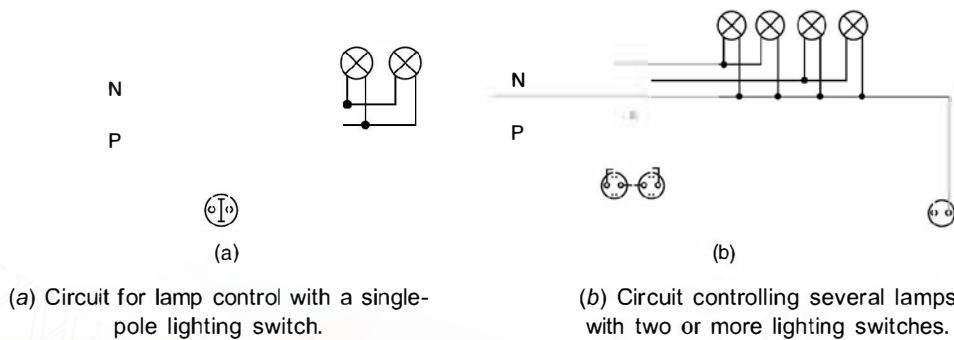

Fig. 11.4

Fig. 11.5 (a) shows circuit for control of three lamps in one room by a chandelier multi way switch. As can be seen that the first turn of the switch lights one lamp, the second turn lights two lamps, but the first lamp goes out. The third turn will light up all the three lamps, and when the fourth turn is made, all the lamps go out. The circuit diagram also shows that a SOCKET is connected in the circuit near the multi-way switch.

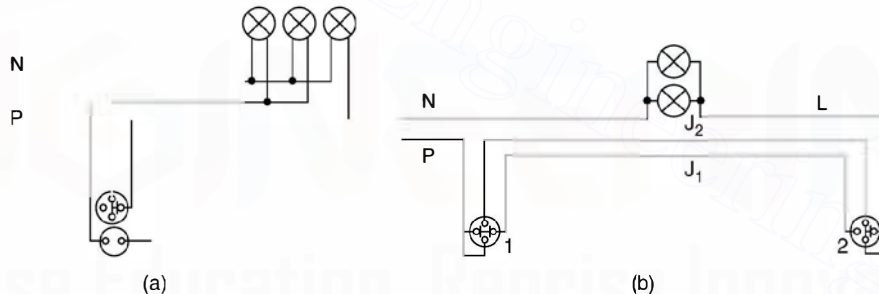
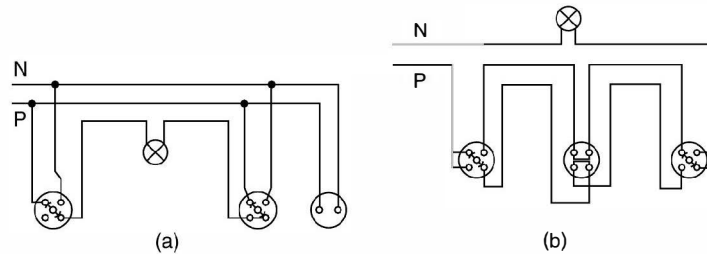

Fig. 11.5 Circuit for controlling a group of lamps from two different places.

Fig. 11.5 (b) shows a circuit by which independent control of lamps from two different places (Stair Case Wiring) is carried out with the help of corridor switches. It can be seen that corridor switch 1 transfers the supply from jumper J_1 to jumper J_2 and that corridor switch 2 performs the same operation with lamp conductor L. This makes the operation of the switches independent of each other, as each of them, in breaking the circuit, simultaneously prepares it for closing by the other switch.

Fig. 11.6 (a) shows the same circuit with a plug socket provided at the end of the circuit whereas Fig. 11.6 (b) shows a circuit used to control lamps from several places.



(a) Circuit for controlling a group of lamps from two different places and also having a plug socket installed at its end.

(b) Circuit for controlling a group of lamps from several places.

Fig. 11.6

The above circuits take in all main ways of controlling lighting installations. It is only possible to change the number of lamps and switches, change their positions relative to one another, include one or another number of plug sockets and arrange them at different places.

11.7 EARTHING SYSTEM

By earthing of electrical installations is meant the direct connection of all the metal non current carrying parts of electrical equipments *e.g.*, metallic framework, body of electric machines, main switch, metallic covering of cables and conduits, distribution board, earth terminal of sockets etc. to earth plate. The earth plate is buried in the ground which has good electrical connection to the surrounding earth. As far as domestic wiring is concerned the electric utility provides earthing to its energy meter. But beyond the meter, earthing is the responsibility of the owner of the house. The owner should make arrangements of his own earthing system with an independent electrode. All appliances which are given connection through the socket outlet *e.g.*, refrigerator, washing machine, drier machine, table fan etc. should be earthed through earth terminal of the socket outlet.

A safe grounding system should provide the following :

- (i) A means to carry and dissipate electric currents into ground under normal and abnormal operating conditions so that not only the equipment should remain safe, the continuity of supply should also be maintained.
- (ii) The personnel working on or around the equipment should not experience any electric shock.

We will discuss here in detail the second aspect of grounding *i.e.*, personnel safety. For this it is important to understand the electrical characteristics of the most important part of the circuit *i.e.*, the human body.

It is to be noted that human body experiences shock due to flow of current through the body and not due to the voltage level. If the human body is properly insulated he or she can even hold bare high voltage wire. It is a usual sight to see birds sitting on the wire of h.t. lines.

However, if the birds span the two HT wire simultaneously, it will turn into a dead short circuit. In general, shock currents are classified based on severity of the shock they cause *e.g.*, currents which produce direct physiological harm are termed primary shock currents, whereas,

those that do not cause direct physiological but may cause involuntary muscular reactions are called secondary shock currents. It is to be noted that the threshold value of current which gives a tingling sensation on the hand or finger when touching an electrically live device differs from person to person. For a normal healthy person a current of 1 mA is the threshold value to produce tingling sensation. Currents of about 10 to 30 mA can cause lack of muscular control.

In most of the cases a current of 100 mA will cause ventricular fibrillation. Currents of higher magnitude may even completely stop the functioning of heart or may cause severe electrical burns. Ventricular fibrillation is that condition when the heart beats in an abnormal and ineffective manner with fatal consequences. Therefore, the threshold value of current is the main criterion for proper grounding of devices. Under threshold condition, there is rapid uncoordinated contractions of the ventricles of the heart thereby the synchronisation between the heart beat and pulse beat is lost. When individual muscle fibres contract independently, they are said to be fibrillating. Fibrillation can occur in the atrial or ventricular muscles. During ventricular fibrillation the *ECG* (Electrocardiogram) is totally disorganised.

A human heart can be considered as a muscle operating rhythmically due to a nerve pulse that provides the heart beat. Therefore, when an external signal due to electric current is sent into the heart which will have different frequency, different from that of the normal heart, it disturbs the rhythmic flow of operation of heart. This condition of operation is known as ventricular fibrillation or arrhythmic operation of heart. Once this arrhythmic condition is set up, it is difficult to stop. It usually requires injection of another electric current to stop the fibrillation and reestablish the normal rhythm. Table 11.2 gives typical effects of Electric shocks current on humans.

Table 11.2. Typical effects of Electric shock currents on humans

<i>50 Hz current</i>	<i>Effect</i>
0–1 mA	No sensation
0–3 mA	Mild sensation
3–5 mA	Pain or annoyance
5–10 mA	Painful shock
10–15 mA	Local muscle contraction
30–50 mA	Breathing difficult, can cause unconsciousness
50–100 mA	Possible ventricular fibrillation of heart
100–200 mA	Ventricular fibrillation of heart certain.

It is to be noted that the effect of electric shock currents not only depends upon the physiological features of a person but the psychological factors also play an important part. The effects of electric current on vital human organs not only depend upon the magnitude of currents but it depends upon the duration and frequency of the current. Humans are more vulnerable to electric shock current at 50–60 Hz. The human body can withstand slightly higher current at 25 Hz and almost five times larger for d.c. current. Similarly at frequencies of 1 KHz or 10 KHz even larger currents can be tolerated. In case of lightning (where the frequency is very high and duration is in μ secs) the human body can withstand very high currents in terms of several hundreds of amperes.

When the human body becomes a part of the electric circuit the current that passes through it, is limited by the body resistance and the resistance of the earthing system of the device to which the person comes in contact. The human body resistance differs from person to person and also it is different when two feet or between one hand and one foot or between two hands. Generally two types of potentials are important from electric shock point of view. These are

- (i) Touch potential and
- (ii) Step potential

When a person touches the electrically live part of a device, the potential between the hand and the foot is known as touch potential. However the potential between the two feet of the person when walking on an electrically conducting and live surface is known as step potential. Usually, the step potentials are smaller in magnitude as compared to the touch potentials.

For grounding a device, a galvanised steel wire is connected to its body and the other end of the wire is connected to a steel rod which is put into the ground upto a certain depth. The pit contains moisturised mixture of salt and charcoal to provide better conductivity. The steel rod or any other electrode is placed in this mixture. Sometimes more than one rod are used to improve the grounding *i.e.*, reduce the earthing resistance. The earthing resistance also depends upon the resistivity of the soil. In transmission lines, tower footing resistance is reduced by using radial or parallel galvanised steel wires in the ground. These are known as counterpoise wires. The acceptable value of grounding resistance varies upon its application *e.g.*, for domestic appliances, the acceptable value is about 1 ohm and for substation equipment a 5 ohm resistance is acceptable. It is seen that the thickness of the rod does not play a major role in reducing the ground resistance as does the length of the rod. Therefore, it is better to use thin but long rods or many small rods.

Some of the safety measures to avoid electric shock are given below :

1. See that all the metallic parts of various equipments and appliances are properly earthed.
2. Before energising the domestic wiring its insulation must be checked.
3. The phase wire must be connected through the switch.
4. Never try to handle or operate any electrical appliances with wet hands or standing on a wet floor.
5. Make it a habit to switch off the supply and then pull out the plug whenever you have finished with a particular gadget.

11.8 FUSES AND HRC FUSES

A fuse is a small piece of wire connected in between two terminals mounted on insulated base and is connected in series with the circuit. The fuse is perhaps the cheapest and simplest form of protection and is used for protecting low voltage equipments against overloads and/or short circuits. The fuse is expected to carry the normal working current safely without overheating and during overloads or short circuits it gets heated up to melting point rapidly. The materials used normally are tin, lead, silver, zinc, aluminium, copper etc. For small values of currents an alloy of lead and tin in the ratio of 37 per cent and 63 per cent respectively is used. For currents more than 15 amperes this alloy is not used as the diameter of the wire will be large and after fusing, the metal released will be excessive. Silver is found to be quite satisfactory as a fuse material because it is

not subjected to oxidation and its oxide is unstable. The only drawback is that it is a relatively costlier material. Therefore, for low range current circuits either lead-tin alloy or copper is used.

Definition

Fuse. Fuse is a device used in circuit for protecting electrical equipments against overloads and/or short circuits.

Fuse element or fuse wire. It is that part of the fuse device which melts when an excessive current flows in the circuit and thus isolates the faulty device from the supply circuit.

Minimum fusing current. Minimum fusing current is a value corresponding to operation in an arbitrary time obtained under prescribed test conditions. Alternatively, it is a value of current corresponding to a chosen value of time indicated on a time/current curve which is itself obtained from prescribed testing condition.

Fuse rating. It is that value of current which when flows through the element, does not melt it. This value of the fuse is less than the minimum fusing current.

Fusing factor. This is the ratio of minimum fusing current to the current rating of fusing element, *i.e.*

$$\text{Fusing factor} = \frac{\text{Minimum fusing current}}{\text{fuse rating}}$$

The fusing factor is always greater than unity.

Prospective current. It is defined as the rms value of current which would flow in a circuit immediately following the fuse when a short circuit occurs assuming that the fuse has been replaced by a link of negligible resistance.

Melting time or pre-arcing time. The time taken from the instant the current that causes a break in the fuse wire starts flowing, to the instant the arc is initiated.

Arcing time. The time taken from the instant of arc initiation to the instant of arc being extinguished.

Total operating time. It is the sum of the pre-arcing and the arcing time.

The most commonly used fuse in 'house wiring' and small current circuits is the semi-enclosed or rewirable fuse. Whenever the fuse wire blows off due to overload or short-circuit, the fuse carrier can be pulled out, the new wire can be placed and the supply can be restored. This looks simple and is really very simple only if the wire is replaced by the correct size. For a layman this may prove dangerous if he replaces the fuse wire by some copper wire not to the specification and there is a possibility of burning the equipment. Besides, the fuse wire, since is exposed to atmosphere, it is affected by ambient temperature. The time-current characteristics of such fuses get deteriorated with time and hence are not reliable for discrimination purposes. These fuses are, therefore, mainly used for domestic and lighting loads. For all important and costly equipments operating at low voltages (upto 33 kV) another class of fuse is used which is known as cartridge fuse. These are described below. When the HRC (High Rupturing Capacity) cartridge fuse link was first introduced, it was designed to satisfy two important requirements. The first was to cope up with the increasing rupturing capacity on the supply system and the second was non-deterioration to overcome the serious disadvantages suffered by the types of semi-enclosed fuses.

Construction of HRC fuse

The HRC fuse consists of a ceramic body usually of steatite, pure silver element, clean silica quartz, asbestos washers, porcelain plugs, brass endcaps and copper tags (see Fig. 11.7). The brass end-caps and copper tags are electro-tinned. The metal end-caps are screwed to the ceramic body by means of special forged screws to withstand the pressure developed under short

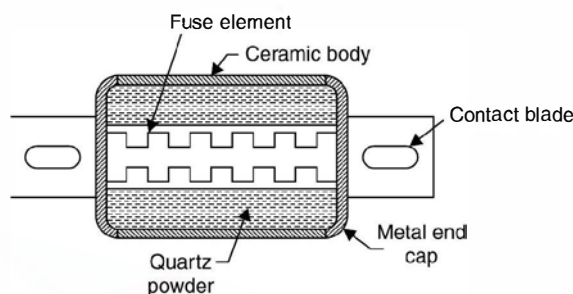

Fig. 11.7 HRC fuse link.

circuit condition. The contacts are welded to the end-caps. The assembly also includes solder of various types, cement and indicator devices. Deterioration of the fuse must involve a change in one or more of these materials or a change in their structure. Normally the fuse element has two or more sections joined by means of a tin joint. The fuse wire is not in the form of a long cylindrical wire as after it melts, it will form a string of droplets and will result into an arc between the droplets. Afterwards these droplets will also evaporate and a long arc will be struck. The purpose of the tin joint is to limit the temperature of fuse under small overload conditions. The melting point of silver is 960°C while that of pure tin is 230°C. As the circuit is overloaded the melting of tin prevents the silver element from attaining high temperature. The shape of the fuse element depends upon the time-current characteristic required.

Fuse operation

When an HRC fuse operates, the element absorbs energy from the circuit and heats until it melts. The heat produced during operation is given by $\int i^2 R dt$ where R is the instantaneous resistance and i the instantaneous current during the operating time. The fuse element melts before the fault current reaches its peak value. As the element melts, it vaporizes and disperses. This action is then followed by a period of arcing during which chemical reaction between the silver vapour and the quartz powder takes place, which further results into building up a high resistance and reduces the current to zero. Thus the arc is quenched. Generally, the filling powder used is quartz-sand as it can absorb heat at a very high rate and it does not evolve appreciable amount of gas.

Cut-off Current

When an HRC fuse interrupts a heavy fault it exhibits an ability to limit the short circuit current. This ability is referred to as a 'cut off' as shown in Fig. 11.8 and has the effect of reducing the magnetic and thermal stresses both in the system and within the fuse itself under fault conditions. Cut-off is in fact one of the main reasons why HRC fuse is so successful as a protective device and it is at times preferred over the circuit breaker of low ratings. Due to this property of

the HRC fuse the operating time is as low as 1/4th of a cycle. The maximum to which the fault current reaches before the fuse melts is called the cut-off current.

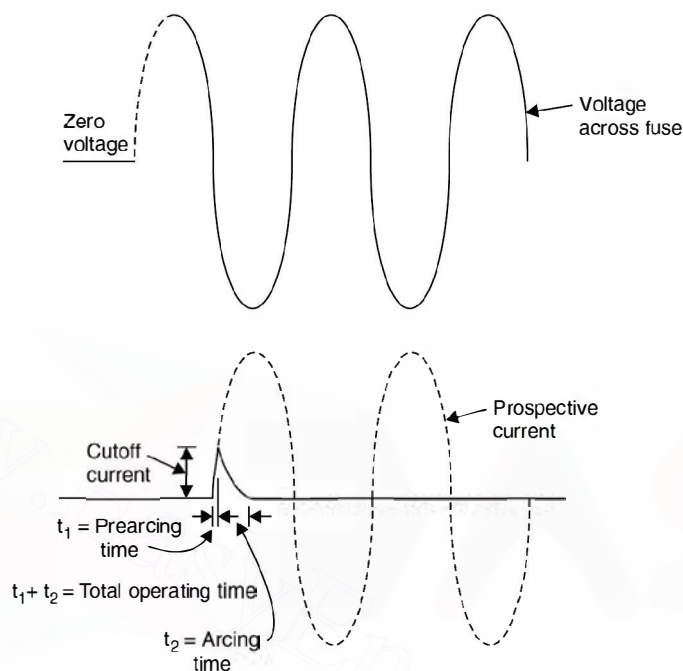

Fig. 11.8 Cut-off characteristic of HRC fuse.

Properties of HRC Fuses

The careful designs of HRC fuses have overcome the disadvantages of the conventional rewirable fuses and their properties are described as follows :

(i) *Fast operation.* The HRC fuse interrupts the short circuit current long before its maximum value is attained which is not true in case of CBs. This property of the HRC fuse reduces both thermal and magnetic stresses on the equipment to be protected and the short circuit fault is interrupted well within the first quarter of a cycle.

(ii) *Rupturing capacity.* The rupturing capacity of a fuse is expressed in terms of MVA and is equal to the product of service voltage and the rms value of the prospective current it can handle. Since the fuse melts much before the current reaches prospective value due to its cut-off property, it is clear that a fuse is never called upon to carry a current equal to its rupturing capacity. It is to be noted here that the rupturing capacity of a breaker is different from the rupturing capacity of a fuse.

(iii) *Non-deterioration.* This means that all the characteristics of the fuse are maintained throughout its life. As the fuses are called upon to function only once in a while, it is most essential that they should preserve their characteristics throughout their useful life. This also implies that they should not operate inadvertently when carrying normal load currents as so often happens with a rewirable fuse which may fail due to oxidation and reduction of cross-sectional area. This property of HRC fuses is very important and is achieved by the hermetic

sealing of the silver element within the fuse body with the help of special cementing and the soldering of the end caps. It has been found that HRC fuses maintain non-deterioration property unimpaired even after approximately 20 years of their manufacture.

(iv) *Low-temperature operation.* This is required to eliminate the deterioration of the fuses and to prevent overheating of associated contacts. This is achieved by employing fabricated elements of pure silver which are specially designed to give a low temperature rise when carrying their full-rated current.

(v) *Accurate discrimination.* By this characteristic is meant that an HRC fuse on a distribution system will isolate the faulty section from the healthy section whenever a fault takes place. In case of an HRC fuse it is found that the time of operation is inversely proportional to the prospective short circuit current over a much wider range of fault condition and, within practical limits, while the values of prospective short circuit current increase, the time of operation will continue to decrease without reaching a definite minimum. This means that a fuse of low current rating will blow before a fuse of a higher rating, no matter how heavy the fault. It is, therefore, desirable while designing the installation from the view point of discrimination to use fuses of the same design and characteristics throughout, which will ensure that time-current characteristics of each succeeding current size will not cross and the characteristics will be parallel to one another upto the maximum values of fault current.

Arc voltage within safe limits. Whenever an inductive circuit is interrupted, there is likelihood of large voltages induced. The magnitude of such voltages depend upon the magnitude of the short circuit to be interrupted and the circuit constants. A careful design of the HRC fuse controls these over voltages and keeps them within safe limits.

Low cost. It is known that because of the cut-off characteristics of the HRC fuse, for the same rupturing capacity the actual current to be interrupted by an HRC fuse is much less as compared to any other interrupting device and hence it is less expensive as compared to other interrupting devices. It is, therefore, usual to employ a circuit breaker of low rupturing capacity backed up by an HRC fuse where circuit breakers are necessary for other reasons. A combination of these two circuit interrupting devices works as follows. Whenever there is an overload the CB trips whereas for short circuits the HRC fuse operates.

Applications of HRC Fuses

The applications of HRC fuses are enormous but a few very important are: (i) protection of cables, (ii) protection of bus bars, (iii) protection of industrial distribution system, (iv) contactor gear for motor control, (v) earth faults—both of low and high magnitude, (vi) semi-conductor rectifiers and (vii) aircraft.

It is to be noted that the HRC fuses cover a very wide range of applications. This involves the principles of fuse design in varying degrees. For special application, the parameters of the fuse are defined to close limits. The design of HRC fuses for the same rupturing capacities for protecting an SCR are different from the one for protecting cables.

An HRC fuse rated for 150 amps continuous rating and 200 kA rupturing capacity at 400 V used for protecting a semi-conductor device weighs about 30 gm whereas an industrial application HRC fuse rated for 100 amps and 250 kA rupturing capacity weighs about 200 gms. The HRC fuses have been used for protecting aircraft equipments and offer many advantages not available by alternative means.

Within wide limits HRC fuses are not affected by frequency. For practical purposes, a fuse tested and rated at 50 Hz is satisfactory for 60 Hz duty and vice versa. As frequency tends towards d.c., the interrupting capability of the fuse at the lower and medium overcurrents may be less, because it is in these zones that d.c. duty is the more onerous. A fuse which has been tested and rated at a given frequency will almost invariably safely interrupt short-circuit faults of higher frequency.

11.8.1 Calculation of fuse rating

In order to select fuse link current rating, the following procedure should be followed :

1. The fuse current rating should be equal to or greater than the design load current for any given section of a wired circuit. From example 11.1, the designed current for light circuit is

$$\frac{3 \times 800}{230} = 10.43 \text{ A}$$

From table 11.3, the appropriate fuse link rating (next higher value) is 15 A and size of fuse is 1.5 sq. mm.

2. In the power circuit the fuse link current rating should be equal to or greater than the value of starting current divided by the factor 2.5. For example (11.3) if we assume that the starting current is about 6 times the full load current; the starting current is

$$21.1 \times 6 \approx 127 \text{ Amps.}$$

Hence the rating of the fuse link is $\frac{127}{2.5} \approx 50 \text{ Amp.}$

From Table 11.4 for the power circuits, the rating of the fuse link (next higher value) comes out to be 60 A. It is to be noted that when severe starting conditions are met with, the starting current is dividing by 1.5 instead of 2.5. These two factors have been obtained through lot of experimentation work.

Table 11.3. Selection of fuse link for lighting load

Current rating of fuse link, <i>a</i>	Size of conductor (sq. mm)		
	of wires		
	<i>run exposed</i>	<i>run in conduit pipe</i>	<i>of cables</i>
10	1.5	1.5	1.5
15	2.5	2.5	1.5
20	4	4	2.5
25	4	4	2.5
35	6	6	6
60	10	10	10
80	16	16	16
100	16	25	25
125	25	35	35
160	35	50	50
200	50	70	70

Table 11.4. Selection of fuse link for Power circuits

Current rating of fuse link <i>a</i>	Size of conductor (sq. mm) in wires and cables					
	of branch circuits installed			of power mains installed		
	<i>open</i>	<i>conduit in pipe</i>	<i>in cable runs</i>	<i>open</i>	<i>in conduit pipe</i>	<i>in cable runs</i>
15	1.5	1	1.5	1.5	1.5	–
20	2.5	1	1.5	2.5	2.5	–
25	4	1.5	1.5	4	2.5	1.5
35	4	2.5	1.5	4	4	2.5
60	6	4	1.5	6	6	4
80	10	4	2.5	10	10	10
100	16	6	4	16	16	16
125	16	10	6	16	16	16
160	25	10	10	25	25	25
200	35	16	16	35	35	35

| PROBLEMS |

- 11.1. Name different types of domestic wiring and discuss and compare their performance briefly.
- 11.2. Explain what specifications for wires used for domestic wiring are normally required.
- 11.3. Discuss various factors to be considered for deciding size of conductors for domestic wiring.
- 11.4. Draw a neat diagram of distribution board for domestic wiring and explain the function of each component used.
- 11.5. Describe different types of cables used for domestic wiring.
- 11.6. Draw neat-diagram and explain the operation of the following lighting control circuits.
 - (i) Circuit for controlling several lamps with two or more lighting switches.
 - (ii) Control of lamp from two different places and a plug socket.
 - (iii) Control of a group of lamps from several places
 - (iv) Controlling lamps with a chandelier multi-way switch.
 - (v) Controlling a group of lamps from two different-places.
- 11.7. Discuss the functions of grounding system in distribution networks. What are the effects of bad grounding on personnel working on power system networks ?
- 11.8. Explain the terms touch potential and step potential, primary and secondary shocks.
- 11.9. List out some safety measures against electric shocks.
- 11.10. What are rewirable fuses and HRC fuses ? Discuss their construction and principle of operation and application.
- 11.11. Explain clearly how a fuse rating is selected for
 - (i) Lighting circuit
 - (ii) Power circuit.
- 11.12. Discuss the advantages of HRC fuse over rewirable fuses.

MULTIPLE CHOICE QUESTIONS

1. In an a.c. circuit having R , L and C in series and operating on lagging $p f$, increase in frequency will
 - (a) reduce the current.
 - (b) increase the current.
 - (c) (a) and (b) are possible.
 - (d) have no effect on current drawn.
2. In a circuit, voltage and current are given by

$$V = 10 \sin (\omega t + 30^\circ)$$
 and

$$i = 10 \sin (\omega t - 30^\circ)$$
 The power consumed in the circuit is
 - (a) 100 watts
 - (b) 50 watts
 - (c) 25 watts
 - (d) 12.5 watts.
3. A series circuit is given by $z = 5 - j12$, its susceptance is
 - (a) $5/13$
 - (b) $5/169$
 - (c) $12/13$
 - (d) $12/169$.
4. In a pure LC circuit (parallel) under resonance condition, current drawn from the supply main is
 - (a) Very large
 - (b) $V\sqrt{LC}$
 - (c) V/\sqrt{LC}
 - (d) Zero.
5. The current response as a function of frequency in a series resonant circuit is given by

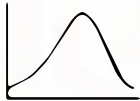
(a) 

(b) 

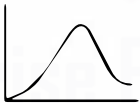
(c) 

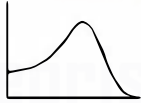
(d) 
6. A drawn wire of resistance 5Ω is further drawn so that its diameter becomes one fifth. Its resistance will now be (volume remaining same).
 - (a) 625
 - (b) 125
 - (c) 25
 - (d) None of these.
7. A 500 watt 220 V bulb is supplied with 110 volts. Power consumption by the bulb will be
 - (a) 250 watt
 - (b) 125 watt
 - (c) slightly more than 125 watt
 - (d) slightly less than 125 watt.
8. In series resonance circuit, increasing inductance to twice its value and reducing capacitance to half its value
 - (a) will change the resonance frequency.
 - (b) will change the impedance at resonance frequency.

- (c) will change the maximum value of current.
 (d) will increase the selectivity of the circuit.

9. For the circuit shown in figure the value of current I is

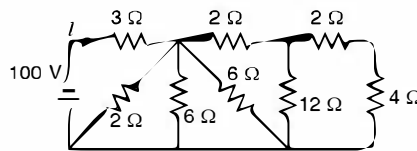

Fig. 1

- (a) 10 A
 (b) 15 A
 (c) 20 A
 (d) 25 A.
10. The maximum power that can be distributed in the load in the circuit shown is
- (a) 3 watts
 (b) 6 watts
 (c) 6.75 w
 (d) 13.5 watt

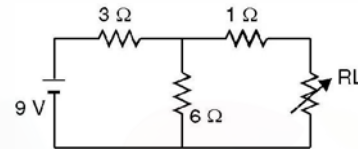

Fig. 2

11. In delta connected circuit when one resistor is open, the power will be
- (a) zero
 (b) reduced to 1/3
 (c) reduced by 1/3
 (d) unchanged.
12. A resistance of 10 ohm is connected in one branch of a network. The current in this branch is 2 A. If this 10 Ω resistor is replaced by a 20 ohms resistance, the current in this branch
- (a) may be more or less than 2 A
 (b) will be more than 2 A
 (c) will be less than 2 A
 (d) none of these.
13. If $V = a + jb$ and $I = (c + jd)$, the power is given by
- (a) $ac - bd$
 (b) $ac + bd$
 (c) $bc - ad$
 (d) $bc + ad$.
14. KCL is a consequences of law of conservation of
- (a) energy
 (b) charge
 (c) flux
 (d) all the above .
15. The current in the 1 Ω resistor is
- (a) 5 A
 (b) 10 A
 (c) 15 A
 (d) zero.

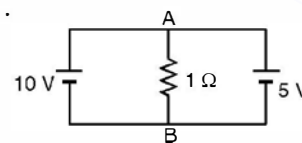

Fig. 3

16. The current in a 5 Ω resistor branch in a linear network is 5A. If this branch is replaced by a resistor of 10 Ω, the current in this branch will be
- (a) 5 A
 (b) 10 A
 (c) less than 5 A
 (d) none of the above.

MULTIPLE CHOICE QUESTIONS

381

17. The potential of the point A in the given network

(a) 6 V
 (b) 7 V
 (c) 8 V
 (d) none of the above.

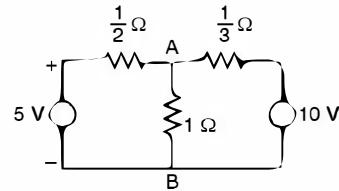

Fig. 4

18. The current through $8\ \Omega$ branch is

(a) 1 A
 (b) 0.5 A
 (c) 1.5 A
 (d) none of the above.

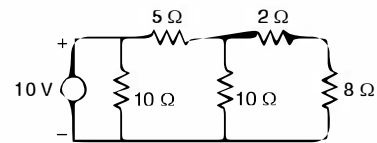

Fig. 5

19. Three identical impedances are connected in delta to a 3-phase supply of 400 V. The line current is 34.65 A and the total power taken is 14.4 kW. The resistance of the load in each phase (in ohms) is

(a) 20
 (b) 16
 (c) 12
 (d) 10.

20. A coil having a resistance of 5 ohms and inductance of 0.1 H is connected in series with a condenser of capacitance $50\ \mu\text{F}$. A constant alternating voltage of 200 volts is applied to the circuit. The voltage across the coil at resonance is

(a) 200 volts
 (b) 1788 volts
 (c) 1800 volts
 (d) 2000 volts.

21. If R_g in the circuit shown in the given figure is variable between $20\ \Omega$ and $80\ \Omega$, then the maximum power transferred to the load R_L will be

(a) 15 W
 (b) 13.33 W
 (c) 6.67 W
 (d) 2.4 W.

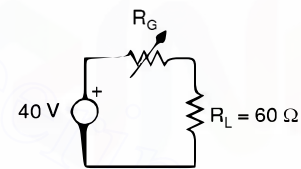

Fig. 6

22. Under the conditions of maximum power transfer from an a.c. source to a variable load

(a) the load impedance must also be inductive, if the generator impedance is inductive
 (b) the sum of the source and load impedances is zero
 (c) the sum of the source reactance and load reactance is zero
 (d) the load impedance has the same phase angle as the generator impedance.

23. In the delta equivalent of the given star-connected impedance Z_{QR} is equal to

(a) $40\ \Omega$
 (b) $(20 + j10)\ \Omega$
 (c) $\left(5 + j\frac{10}{3}\right)\ \Omega$
 (d) $(10 + j30)\ \Omega$.

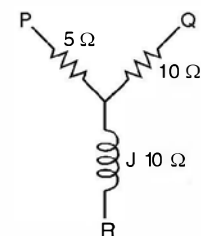

Fig. 7

24. The power delivered to a three-phase load can be measured by the use of 2 wattmeters only when the
- (a) load is balanced (b) load is unbalanced
 (c) 3-phase load is connected to the source through 3 wires
 (d) 3-phase load is connected to the source through 4 wires.
25. A 3-phase star-connected symmetrical load consumes P watts of power from a balanced supply. If the same load is connected in delta to the same supply, the power consumption will be
- (a) P (b) $\sqrt{3}P$
 (c) $3P$ (d) not determinable from the given data.
26. Consider the circuit shown in the given figure. For maximum power transfer to the load, the primary to secondary turns ratios must be :

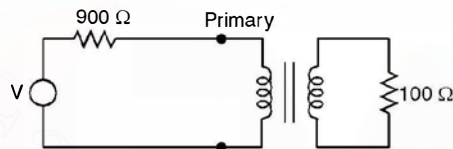

Fig. 8

- (a) 9 : 1 (b) 3 : 1
 (c) 1 : 3 (d) 1 : 9.
27. In two-wattmeter method of power measurement, one of the wattmeters will show negative reading when the load pf angle is strictly
- (a) less than 30° (b) less than 60°
 (c) greater than 30° (d) greater than 60° .
28. A 3-phase, 3 wire supply feeds a load consisting of three equal resistors connected in star. If one of the resistors is open circuited, then the percentage reduction in the load will be
- (a) 75 (b) 66.66
 (c) 50 (d) 33.33.
29. An a.c. source of 200 V rms supplies active power of 600 W and reactive power of 800 VAR. The rms current drawn from the source is
- (a) 10 A (b) 5 A
 (c) 3.75 A (d) 2.5 A.
30. Which one of the following networks is the Y equivalent of the circuit shown in Fig. 9 ?

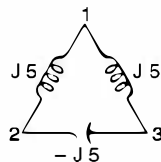
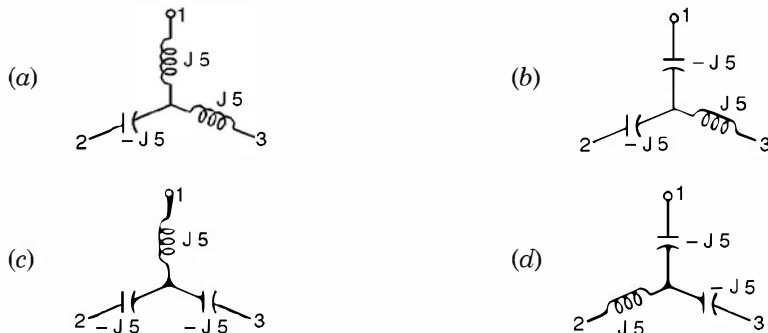

Fig. 9



31. Which one of the following circuits is the delta equivalent of the star circuit given in Fig. 10 ?

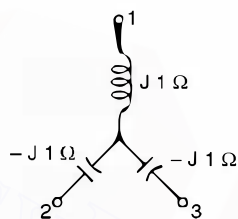
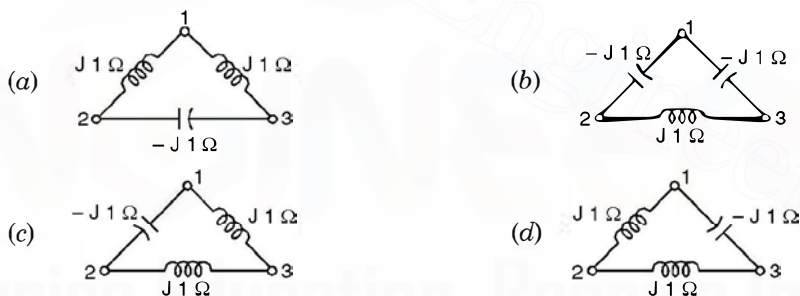

Fig. 10



32. For the circuit shown in the adjoining figure, the voltage V_{AB} is

- (a) 6 V
- (b) 10 V
- (c) 25 V
- (d) 40 V.

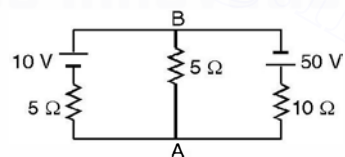

Fig. 11

33. If permanent brake magnet is moved away from the spindle of the moving disc, energy meter
- (a) will run fast
 - (b) will run slow
 - (c) no effect
 - (d) will come to a stop.
34. If voltage supply to the energy meter is more than the rated and no load is connected, the energy meter may run

- (a) slow (b) fast
(c) could be (a) and (b) (d) not run at all.
35. Which of the following materials will be used as a resistance for extending the range of measurement of a voltmeter ?
(a) Copper (b) Steel
(c) Aluminium (d) Manganin.
36. The advantage of PMMC type instrument is
(a) low power consumption (b) no hysteresis loss
(c) efficient current damping (d) all of the above.
37. Which of the following types of instruments can be used for d.c. only ?
(a) Moving iron-Attraction (b) Moving iron-Repulsion
(c) Permanent magnetic moving coil (d) Hot wire.
38. To measure power in a 3-phase circuit 2-wattmeters are used. It is applicable only if the load is
(a) Balanced (b) Unbalanced
(c) (a) and (b)
(d) Three wattmeters are required for 3-phase circuits.
39. By mistake voltmeter and ammeter are connected as shown in adjoining figure, then
(a) both voltmeter and ammeter will burn
(b) only ammeter will burn
(c) only voltmeter will burn
(d) none will burn.
40. An ordinary electro-dynamometer wattmeter is not suitable for low p.f. power measurement because of
(a) power loss in voltage coil (b) power loss in current coil
(c) inductance of voltage coil (d) All of the above.
41. In the power measurement by two-wattmeter method, reading of one wattmeter will be negative, if the p.f. of the load is
(a) 0.5 lag (b) 0.8 lag
(c) 0.4 lead (d) none of the above.
42. A moving coil galvanometer has a resistance of 4 ohms and gives full scale deflection when carrying 30 mA. The instrument can be used to measure 150 volts by connecting in series with the instrument a resistance of
(a) 9996 Ω (b) 5004 Ω
(c) 5000 Ω (d) 4996 Ω .
43. A 15 volt moving iron voltmeter has a resistance of 300 ohms and an inductance of 0.12 henry. The instrument reads correctly on d.c. and on a.c. at 35 Hz it shows a voltage of 14.75 V. What will be its voltage reading at 100 Hz ?

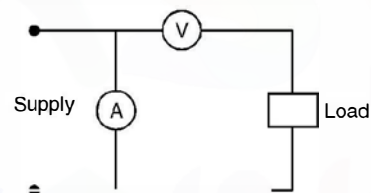

Fig. 12

- (a) 15.4 V (b) 15 V
(c) 14.85 V (d) 14.5 V.
44. If torque to weight ratio of an instrument is low, it can be concluded that
(a) the meter will have uniform scale (b) the meter will have non-uniform scale
(c) the sensitivity of the meter will be high (d) the sensitivity of the meter will be low.
45. A moving coil instrument gives full deflection with 15 mA. The instrument has resistance of 5Ω . If a resistance of 0.08 ohm is connected in parallel with the instrument, the instrument will be capable of reading upto
(a) 150 mA (b) 600 mA
(c) 750 mA (d) 950 mA.
46. In which instrument the deflecting torque depends upon frequency
(a) Hot wire (b) Moving coil
(c) Moving iron (d) Induction type.
47. A dynamometer type wattmeter with its voltage coil connected across the load side of the instrument reads 180 W. If the load voltage be 200 V and voltage coil branches a resistance of 2000Ω , the power being taken by the load is
(a) 200 W (b) 180 W
(c) 160 W (d) 150 W.
48. A permanent magnet MC type ammeter and a MI are connected in series with the output of a half wave rectifier. If the moving iron type instrument reads 5A, moving coil would read
(a) zero (b) 5 A
(c) 3.18 A (d) 2.5 A.
49. A meter has a constant of 600 revolutions per kW hr. If the meter makes 10 revolutions in 20 secs, the load is
(a) 0.75 kW (b) 1.5 kW
(c) 3 kW (d) 6 kW.
50. In a moving iron instrument 12 A current causes a deflection of the needle by 60° . For a deflection of 15° the current required will be
(a) 9 A (b) 6 A
(c) 4 A (d) 3 A.
51. Which of the following instruments can have full scale deflection of 300° ?
(a) Hot wire (b) Induction
(c) Moving coil (d) Moving iron.
52. Which of the following does not change in an ordinary transformer ?
(a) Voltage (b) Current
(c) Frequency (d) all of the above.
53. If R_s is the resistance of secondary winding of the transformer and K is the transformation ratio, the equivalent secondary resistance as referred to primary side is given by
(a) KR_s^2 (b) K^2R_s
(c) R_s/K (d) R_s/K^2 .

54. At no load the current taken by a transformer
 (a) lags behind the applied voltage by 80° (b) lags behind the applied voltage by 50°
 (c) leads the applied voltage by 50° (d) leads the applied voltage by 80° .
55. Which part of the transformer is subjected to maximum heating
 (a) core (b) winding
 (c) oil (d) frame.
56. For a transformer if the full load copper losses are A and iron losses are B, then the load at which these two losses would be equal, is given by
 (a) $FL \times \frac{A}{B}$ (b) $FL \times \frac{B}{A}$
 (c) $FL \sqrt{\frac{A}{B}}$ (d) $FL \sqrt{\frac{B}{A}}$.
57. A transformer has at full load iron loss of 900 W and copper loss of 1600 W. At what percent of the load the transformer will have maximum efficiency ?
 (a) 100% (b) 90%
 (c) 75% (d) 50%.
58. A transformer has full load copper loss of 800 W and core loss of 600 W. Total loss at no load will be approximately
 (a) 1400 W (b) 1100 watt
 (c) 1000 W (d) 600 watts.
59. For a transformer operating at constant load current, maximum efficiency will occur at a p.f.
 (a) zero (b) unity
 (c) 0.8 lead (d) 0.8 lag.
60. The efficiency of a transformer at full load 0.8 p.f. lag is 95%. The efficiency at 0.8 p.f. lead is
 (a) 99% (b) 95.5%
 (c) 95% (d) 90%.
61. A transformer can have zero voltage regulation at p.f.
 (a) zero (b) lag
 (c) lead (d) unity.
62. The leakage impedances of primary and secondary windings of a transformer are $(3 + j4) \Omega$ and $(1 + j1.3) \Omega$ respectively. It can be concluded that the transformer has
 (a) low voltage primary (b) low voltage secondary
 (c) high voltage secondary (d) no conclusions can be drawn.
63. In a transformer the resistance between the primary and secondary must be
 (a) zero (b) 1 k Ω
 (c) 100 k Ω (d) Infinite.

64. In a transformer connected to constant voltage source, increase in secondary load current will ultimately
- reduce the mutual flux in the core
 - increase the mutual flux in the core
 - not cause any change in the magnitude of mutual flux
 - decrease the mutual flux when the secondary current is below 0.8 pf lag.
65. In a step down transformer, there is change of 10 amp in the load current, this results in change of supply current of
- 10 amps
 - less than 10 amps
 - more than 10 amps
 - 20 A.
66. Negative voltage regulation is indicative that
- the load is inductive only
 - the load is inductive or resistive
 - the load is capacitive
 - in all cases.
67. The maximum transmission (a.c.) voltage in India is
- 132 kV
 - 220 kV
 - 400 kV
 - 500 kV.
68. The value of the resistance R_L for maximum power transfer will be

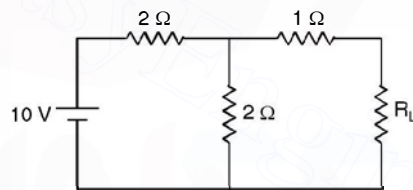

Fig. 13

- $5\ \Omega$
 - $2\ \Omega$
 - $6\ \Omega$
 - $3\ \Omega$.
69. The Thevenin's equivalent resistance when the current is to be obtained through $2\ \Omega$ resistance is

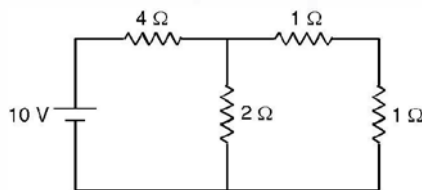

Fig. 14

- $5\ \Omega$
 - $2\ \Omega$
 - $1.33\ \Omega$
 - $1.5\ \Omega$.
70. If an induction motor is started with DOL starter and the starting torque is 300 Nm, if started with star/delta starter, the starting torque is

- (a) 300 Nm (b) 600 Nm
(c) 900 Nm (d) 100 Nm.
71. When oil in a transformer decomposes the major gas that it produces is
(a) oxygen (b) nitrogen
(c) hydrogen (d) none of these.
72. The torque-speed characteristic of a d.c shunt motor is
(a) a rectangular hyperbola (b) a drooping straight line
(c) a parabola (d) none of the above.
73. A d.c. series motor for large armature current, the torque is proportional to
(a) I_a (b) I_a^2
(c) $\sqrt{I_a}$ (d) $I_a^{2/3}$.
74. In case of series resonance the supply voltage depends upon the voltage across the
(a) inductance (b) capacitance
(c) resistance (d) none of these.
75. The direction of rotation of a d.c. shunt motor is reversed by
(a) reversing armature connection
(b) interchanging the armature and field connection
(c) adding resistance to the field circuit
(d) reversing supply terminals.
76. The armature of a d.c. m/c is laminated
(a) to reduce the hysteresis losses
(b) to reduce the eddy current losses
(c) to reduce the inductance of the armature
(d) to reduce the mass of the armature.
77. If the field of a d.c. shunt motor is opened
(a) It will continue to run at its rated speed
(b) the speed of the motor will become very high
(c) the motor will stop
(d) the speed of motor will decrease.
78. What will happen if the supply terminals of d.c. shunt motor are interchanged ?
(a) Motor will stop
(b) The motor will run in the same original direction
(c) The direction of rotation will reverse
(d) Motor will run at a speed lower than the normal speed in the same direction.
79. If the armature current of a d.c. series motor is increased keeping the field flux constant, then the developed torque
(a) increases proportionally (b) decreases in the inverse ratio
(c) remains constant (d) increases $\propto I^2$.

80. The core losses in a d.c. m/c occur in
(a) the armature only (b) the pole faces only
(c) the yoke only (d) both the armature and pole faces.
81. A transformer has a core loss of 64 watts and copper loss of 144 watt when it is carrying 20% overload current. The load at which this transformer will operate at the maximum efficiency is
(a) 80% (b) 66%
(c) 120% (d) 44%.
82. The short circuit test in a transformer is used to determine
(a) iron loss at any load (b) copper loss at any load
(c) hysteresis loss (d) Eddy current loss.
83. A 5-ohm load is connected to the secondary of a 1100/110 V power transformer. The effective load on 1100 V bus bar is
(a) 50 ohm (b) 500 ohm
(c) 0.5 ohm (d) 0.05 ohm.
84. A transformer has percentage resistance and reactances of 1% and 4% respectively. Its regulation at p.f. 0.8 lag and lead are respectively
(a) 3.2% and - 1.6% (b) 6% and - 4%
(c) 4.8% and - 3.2% (d) none of these.
85. A synchronous motor can run at
(a) a leading p.f. (b) unity p.f.
(c) lag, lead or unity p.f. (d) zero p.f.
86. If the field of synchronous motor is under excited, the p.f. will be
(a) lagging (b) leading
(c) unity (d) none of these is necessary.
87. When a synchronous motor is started, the field winding is initially
(a) short circuited (b) excited by a d.c. source
(c) open circuited (d) none of these.
88. For a given load the armature current of a synchronous motor is minimum when the p.f. is
(a) unity (b) slightly less than unity and lag
(c) slightly less than unity and lead (d) none of these.
89. The largest size alternator used in India is
(a) 100 MW (b) 210 MW
(c) 500 MW (d) 1000 MW.
90. The power drawn by 3-phase induction motor when first run in star connection and then in delta is
(a) same (b) $\sqrt{3}$ times that of star

- (c) 3 times that of star (d) $\frac{1}{\sqrt{3}}$ times that of star.
91. A 3-phase induction motor draws a current of 20 A from mains if started by direct switching. If an auto transformer with 50% tapping is used for starting the current drawn from the mains is
 (a) 20 A (b) 10 A
 (c) 5 A (d) 40 A.
92. A change of 5% in supply voltage to a 3-phase IM will produce the approx change in the torque of
 (a) 5% (b) 7.5%
 (c) 10% (d) 15%.
93. A 50 Hz 10 pole 3-phase IM is used to drive a 60 Hz 3-phase alternator. The no. of poles of the alternator is
 (a) 10 (b) 6
 (c) 12 (d) 16.
94. The mechanical load in an induction motor can be represented by
 (a) $\frac{R_{2e}}{s} - R_{2e}$ (b) $R_{2e} - \frac{s}{R_{2e}}$
 (c) $\frac{1}{s(R_{2e} - 1)}$ (d) $R_{2e} \left(\frac{1}{s} + 1 \right)$.
95. In an induction motor the rotor input is 600 W and slip is 4%. The rotor copper loss is
 (a) 700 W (b) 600 W
 (c) 650 W (d) 24 watts.
96. In an induction motor the ratio of the rotor output to rotor input is 0.96. The percentage slip is
 (a) 0.04% (b) 4%
 (c) 6% (d) 12%.
97. In a 3-phase IM, the maximum torque
 (a) is proportional to R_{2e} (b) is proportional to R_{2e}^2
 (c) does not depend upon R_{2e} (d) none of these.
98. If a synchronous m/c is overexcited it takes lagging vars from the system when it is operated as
 (a) Synchronous motor (b) Synchronous generator
 (c) Synchronous motor as well as generator (d) None of the above.
99. If a synchronous motor is underexcited it takes lagging vars from the system when it is operated as
 (a) Synchronous motor (b) Synchronous generator

- (c) Synchronous motor as well as synchronous generator
(d) None of the above.
100. The frequency of voltage generated by an alternator having 8 poles and rotating at 250 rpm is
(a) 60 Hz (b) 50 Hz
(c) 25 Hz (d) $16\frac{2}{3}$ Hz.
101. An alternator is delivering a balanced load at unity p.f. The phase angle between line voltage and line current is
(a) 90° (b) 60°
(c) 30° (d) 0° .
102. A synchronous phase modifier as compared to a synchronous motor used for mechanical loads has
(a) Larger shaft and higher speed (b) Smaller shaft and higher speed
(c) Larger shaft and smaller speed (d) Smaller shaft and smaller speed.
103. A 100 V/10 V, 50 VA transformer is converted to 100 V/110V auto transformer, the rating of the auto transformer is
(a) 550 VA (b) 500 VA
(c) 110 VA (d) 100 VA.
104. A 100 KVA transformer has maximum efficiency of 98% when operating at half full load. It's full load losses are
(a) $Cu = 2.04$ kW and Iron loss = 0.51 kW
(b) $Cu = 4.08$ kW and Iron loss = 1.02 kW
(c) $Cu = 3.0$ kW and Iron loss = 0.75 kW (d) None of the above.
105. If one phase of supply goes off in the case of 3-phase induction motor, the motor
(a) Comes to a stop
(b) Draws double the initial current and continues to run
(c) Draws $\frac{1}{\sqrt{3}}$ times the initial current and continues to run
(d) None of the above.
106. Induction generator works between the slips
(a) $1 < S < 2$ (b) $0.1 < S < 1.0$
(c) $S < 0.0$ (d) None of the above.
107. The motor which can be used on both ac and dc is
(a) Reluctance motor (b) Induction motor
(c) dc series motor (d) None of the above.
108. For a synchronous phase modifier the load angle is
(a) 0° (b) 25°
(c) 30° (d) None of the above.

109. A salient pole synchronous motor is running at no load, its field current is switched off. The motor will
 (a) Come to a step (b) Continue to run at synchronous speed
 (c) Continue to run at a speed slightly less than synchronous speed
 (d) None of the above.
110. In a network the sum of currents entering a node is $5\angle 60^\circ$. The sum of the currents leaving the node is
 (a) $5\angle 60^\circ$ (b) $5\angle -60^\circ$
 (c) $5\angle 240^\circ$ (d) 15 A.
111. In a synchronous machine, in case the axis of field flux is in line with the armature flux, the machine is working
 (a) as synchronous motor (b) as synchronous generator
 (c) as floating machine (d) the machine will not work.
112. An ideal voltage source is connected across a variable resistance. The variation of current as a function of resistance is given by
 (a) a straight line passing through the origin
 (b) a rectangular hyperbola
 (c) a parabola (d) it could be any one of the above.
113. Pure inductive circuit takes power (reactive) from the a.c. source when
 (a) both applied voltage and current rise (b) both applied voltage and current decrease
 (c) applied voltage decrease but current increases
 (d) (a) and (b).
114. The current in the primary of the given transformer is

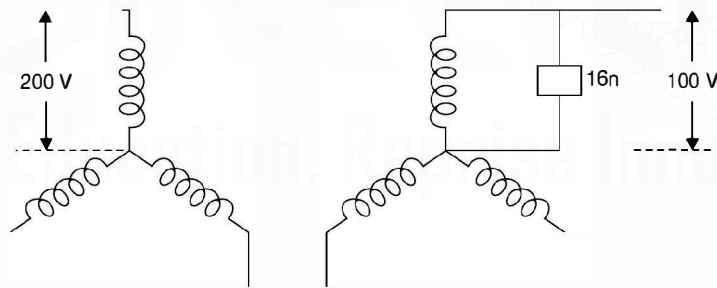

- (a) 10 A (b) 5 A
 (c) $10/\sqrt{3}$ A (d) None of the above.
115. The ratio of weights of copper in an auto transformer and a two-winding transformer for a transformation ratio 3 is
 (a) $\frac{1}{3}$ (b) $\frac{2}{3}$
 (c) $\frac{5}{6}$ (d) none of the above.

116. A synchronous machine has its field winding on the stator and armature winding on the rotor. Under steady running condition, the air gap field
- (a) rotates at synchronous speed w.r.t. rotor
 - (b) rotates at synchronous speed in the direction of rotation of the rotor
 - (c) remains stationary w.r.t. stator
 - (d) remains stationary w.r.t. rotor.
117. In a pure LC parallel circuit under resonance condition, current drawn from the supply mains is
- (a) very large
 - (b) $V\sqrt{LC}$
 - (c) V/\sqrt{LC}
 - (d) Zero.
118. In a circuit the voltage and current are given by $V = (10 + j5)$ and $i = (6 + j4)$. The circuit is
- (a) inductive
 - (b) capacitive
 - (c) resistive
 - (d) it could be any of the above.
119. The power in the circuit of problem 118 is
- (a) 60 watt
 - (b) 20 watt
 - (c) 80 watt
 - (d) 70 watt.
120. The reactive power in the circuit of problem 118 is
- (a) 70 V Ars
 - (b) 60 V Ars
 - (c) 10 V Ars
 - (d) - 10 V Ars.
121. The current at a given point in a certain circuit may be given a function of time as
- $$i(t) = -3 + t$$
- The total charge passing the point between $t = 99$ sec and $t = 102$ sec is
- (a) 112 C
 - (b) 242.5 C
 - (c) 292.5 C
 - (d) 345.6 C.
122. An alternator has a phase sequence of RYB for its phase voltages. In case the field current is reversed, the phase sequence will become
- (a) RBY
 - (b) RYB
 - (c) YRB
 - (d) None of the above.
123. An alternator has a phase sequence of RYB for its phase voltage. In case the direction of rotation of alternator is reversed, the phase sequence will become
- (a) RBY
 - (b) RYB
 - (c) YRB
 - (d) None of the above.
124. Modern high speed synchronous generator used in thermal plants have
- (a) salient pole rotors
 - (b) cylindrical rotor
 - (c) either salient or cylindrical
 - (d) spherical rotor.
125. In a split phase 1-phase induction motor the wire of the main winding as compared to auxiliary winding is
- (a) thinner
 - (b) thicker
 - (c) same size
 - (d) could be either way.

126. The rotor of a 1-phase induction motor is
 (a) a cage or wound rotor (b) always a cage rotor
 (c) always a wound rotor (d) a double cage rotor.
127. In a capacitor start motor, the capacitor is connected
 (a) in series with the main winding (b) in series with the auxiliary winding
 (c) in parallel with the auxiliary winding (d) in series with both the windings.
128. A ceiling fan uses
 (a) split phase motor (b) capacitor start capacitor run motor
 (c) capacitor start motor (d) universal motor.
129. A two-phase servo-motor has
 (a) wound rotor (b) cage rotor
 (c) wound or cage rotor (d) double cage rotor.
130. The motor used in electric toys is
 (a) split phase motor (b) permanent capacitor motor
 (c) shaded pole motor (d) capacitor start motor.
131. The voltage fed to the two windings of a two-phase servo motor must be
 (a) in phase with each other (b) 90° apart with each other
 (c) 180° apart with each other (d) more than 90° but less than 180° apart with each other.
132. A stepper motor is a
 (a) dc motor (b) single phase ac motor
 (c) two-phase motor (d) multi-phase motor.
133. Phantom loading heat run test on transformers is performed by means of
 (a) S.C. Test (b) O.C. Test
 (c) Half time on S.C. and halftime on D.C. test
 (d) Sumpner's Test.
134. A power transformer has its maximum efficiency at $\frac{3}{4}$ th full load. Its iron loss and full load copper loss P_c are related as
 (a) $P_i/P_c = \frac{16}{9}$ (b) $P_i/P_c = \frac{3}{4}$
 (c) $P_i/P_c = \frac{4}{3}$ (d) $P_i/P_c = \frac{9}{16}$.
135. In case of a transformer the low voltage winding is placed near the core because
 (a) it reduces insulation requirement (b) it reduces hysteresis loss
 (c) it is convenient (d) it reduces eddy current loss.

136. Conservator on a transformer is provided to
 (i) prevent oil from coming in contact with the atmosphere
 (ii) allow breathing and to increase the oil surface exposed to atmosphere
 (iii) allow breathing and also to reduce the oil surface exposed to atmosphere.
 Tick out the correct answer
 (a) only (i) is true (b) only (ii) is correct
 (c) only (iii) is correct (d) (i) (ii) (iii) all are correct.
137. Two transformers connected in parallel share loads in the ratio of their KVA ratings provided their impedances are
 (a) in inverse ratio of their ratings (b) in direct ratio of their ratings
 (c) equal (d) none of the above is necessary.
138. A transformer is operating under no load condition at rated voltage. A small air gap is now cut across the yoke of its core. The maximum flux density and magnetising current respectively.
 (a) decrease and decrease (b) decrease and increase
 (c) increase and increase (d) remain same and increase.
139. A 440/220 V transformer has per unit impedance of 0.1. In order to circulate full load current during short circuit the voltage impressed on high voltage side is
 (a) 22 V (b) 10 V
 (c) 44 volt (d) 20 volt.
140. For fixed primary voltage and secondary load current if the p.f. of the load is changed from 0.6 lead to 0.8 lead, the secondary voltage
 (a) increases (b) decreases
 (c) first decreases and then increases (d) does not change.
141. A transformer has maximum efficiency at full load. Its all day efficiency will be maximum when it is operated
 (a) full load all the time
 (b) full load half the time and $\frac{3}{4}$ th load half time
 (c) full load and half load each half the time
 (d) full load half time and no load half the time
142. Inter poles help commutation in a dc machine by
 (a) aiding the main poles
 (b) causing dynamically induced e.m.f. in the coils undergoing commutation
 (c) causing statically induced e.m.f. in the coils undergoing commutation
 (d) cancelling the armature reaction m.m.f.
143. If the armature current of a d.c. motor is increased keeping the field flux constant, the torque developed
 (a) increases proportionally (b) decreases in inverse ratio
 (c) increases proportional to I^2 (d) remains constant.

144. The critical field resistance of a d.c. shunt generator is
 (a) the value of field circuit resistance above which the generator would fail to excite
 (b) the value of field circuit resistance below which this generator would fail to excite
 (c) the resistance of the field winding (d) none of the above.
145. For a d.c. shunt generator, the critical resistances are for
 (a) load circuit only (b) field circuit only
 (c) load and field circuits (d) none of the two circuits.
146. In Hopkinson's test on two identical d.c. machines the power input to the armature circuit consists of
 (a) rated power of the two machines
 (b) copper loss + no load iron loss + windage and friction loss + stray load loss
 (c) armature copper loss + no load iron loss + stray load loss
 (d) armature copper loss + no load iron loss + windage and friction loss
147. Two coupled d.c. series motors with constant torque load are changed over from series to parallel connection across a fixed voltage supply. The speed of the combined set as compared to original speed becomes
 (a) Twice (b) Half
 (c) $\sqrt{2}$ times (d) no change.
148. A d.c. machine has maximum efficiency when
 (a) iron losses equal copper losses (b) constant losses equal variable losses
 (c) windage and friction losses equal copper losses
 (d) (a) and (b).
149. The d.c. generator used for voltage boost is
 (a) shunt (b) series
 (c) separately excited (d) compound.
150. In a level compound generator the terminal voltage at half load as compared to no load is
 (a) more (b) less
 (c) same (d) none of the above is necessary.
151. A d.c. motor when switched on to supply rotates opposite to its normal direction, the motor is
 (a) series (b) shunt
 (c) differential (d) cumulative.
152. A d.c. series motor is running with a diverter connected across its field winding. If the diverter resistance is increased, the speed of the motor
 (a) increases (b) decreases
 (c) remains unchanged (d) comes to a stop.
153. A d.c. series motor is driving a load with a diverter connected across its armature. If the diverter resistance is decreased the speed of the motor
 (a) increases (b) decreases
 (c) remains unchanged (d) becomes zero.

154. In Swinburne's test for dc machine for determination of efficiency of the machine
(a) both the no load losses and the copper losses are measured
(b) both the no load losses and the copper losses are calculated
(c) The no load losses are calculated and copper losses are measured
(d) the no load losses are measured and copper losses are calculated.
155. A d.c. shunt motor is driving a mechanical load at a rated voltage and rated excitation. If the load torque is doubled, the speed of the motor
(a) increases slightly
(b) decreases slightly
(c) becomes half
(d) becomes double.
156. The core losses in a d.c. machine occur in
(a) the armature only
(b) the yoke only
(c) both the armature and pole faces
(d) the pole faces only.
157. During no load test an induction motor draws power
(a) for core and copper loss
(b) for core and windage and friction loss
(c) for copper loss and windage and friction loss
(d) none of the above is true.
158. In case of a double cage rotor
(a) the outer cage has high resistance and the inner cage low
(b) the outer cage has low resistance and the inner cage high
(c) both the cages have high resistances
(d) both the cages have low resistances.
159. The variable load on a 3-phase induction is electrically represented by
(a) a variable capacitance
(b) a variable inductance
(c) a variable resistance
(d) a combination of variable resistance and inductance.
160. Cogging of induction motor occurs due to
(a) vibrating torque
(b) harmonic synchronous torque only
(c) harmonic induction torque only
(d) both harmonic induction and synchronous torques.
161. The power input to an induction motor at 5% slip is 40 kW. Assuming the stator resistance and core loss to be negligibly small, the torque developed by the motor is
(a) 40 kW
(b) 42 kW
(c) 38 kW
(d) 28 kW.
162. The starting current of an induction motor is five times the full load current and the full load slip is 4%. The ratio of starting torque to full load torque is
(a) 1.6
(b) 1.0
(c) 0.8
(d) 0.866.
163. By adding a resistance in the rotor circuit of a slip ring induction, the starting current and torque respectively

- (a) increase and increase (b) decrease and increase
 (c) decrease and decrease (d) increase and decrease.
164. Star-delta starting is equivalent to auto transformer starting with tapping as
 (a) 33% (b) 86.6%
 (c) 58% (d) 70.7%.
165. Speed control by supply voltage variation is not resorted to as
 (a) the range of speed control is limited (b) It reduces pull out torque
 (c) (a) and (b) (d) none of the above.
166. In the capacitor motor if c_1 is the capacitance required for best starting torque and c_2 is the capacitance required for best running condition, then
 (a) c_1 is approximately equal to c_2 (b) c_1 is much smaller than c_2
 (c) c_1 is much larger than c_2 (d) none of the above is necessary.
167. A synchronous motor is operating at constant load and its excitation is adjusted to give unity p.f. If the excitation is further increased, the p.f. will be
 (a) unity only (b) lead
 (c) lag (d) zero.
168. A synchronous motor is floating on infinite bus at no load. It's excitation is increased
 (a) it will not draw any current (b) it will draw zero p.f. lagging current
 (c) it will draw unity p.f. current (d) it will draw zero p.f. leading current.
169. The salient pole rotors are not used for high speed turbo alternator because of
 (a) high centrifugal force and windage loss (b) high eddy current loss
 (c) excessive bearing friction (d) all of the above.
170. The diameter and length of the stator bore of a turbo-alternator as compared to a hydro alternator for the same ratings are respectively
 (a) smaller and larger (b) smaller and smaller
 (c) larger and smaller (d) larger and larger.
171. In calculating voltage regulation for an alternator tick out the correct answer
- | emf. method | mmf. method |
|-----------------|--------------|
| (a) optimistic | pessimistic |
| (b) optimistic | optimistic |
| (c) pessimistic | optimistic |
| (d) pessimistic | pessimistic. |
172. Short circuit ratio (SCR) of a synchronous machine is defined as the ratio of
 (a) field current required to produce rated voltage on full load and field current required to produce rated current on S.C.
 (b) field current required to produce rated voltage on O.C. and field current required to produce rated armature current on S.C.
 (c) field current required to produce rated voltage on full load and field current required to produce rated voltage on S.C.

- (d) field current required to produce rated voltage on S.C. and field current required to produce rated current on S.C.
173. An alternator is delivering certain power at lagging p.f. and is connected to an infinite bus. If its excitation is increased, its p.f. and power angle respectively.
- (a) increase and increase (b) increase and decrease
(c) decrease and increase (d) decrease and decrease.
174. In Q. 173, if excitation is increased, other conditions remaining same, the reactive power and current respectively
- (a) increase and increase (b) increase and decrease
(c) decrease and increase (d) decrease and decrease.
175. In Q. 173, if the alternator is delivering power at lead p.f. and if the excitation is increased, its p.f. and power angle respectively
- (a) increase and increase (b) increase and decrease
(c) decrease and increase (d) decrease and decrease.
176. An alternator is delivering certain power at lagging p.f. and is connected to an infinite bus. If steam input to the turbine is increased, the p.f. and power angle respectively
- (a) increase and increase (b) increase and decrease
(c) decrease and increase (d) decrease and decrease.
177. A synchronous motor is taking certain amount of power at lag p.f. when connected to an infinite bus. If its excitation is increased, then p.f. and power angle of the motor respectively.
- (a) increase and increase (b) increase and decrease
(c) decrease and increase (d) decrease and decrease.
178. A 1- ϕ . transformer rated for 400/100 V, 1 kVA 50 Hz has load resistance of 100 ohm. The load resistance as viewed from primary side (400 V) is
- (a) 100 ohm (b) 25 ohm
(c) 400 ohm (d) 1600 ohm.
179. Buchholtz relay in a transformer is placed in between
- (a) the LV winding and the bushing (b) the tank and the conservator
(c) the HV winding and the bushing (d) the conservator and the breather.
180. The transformer stampings are annealed before being used for building the core to
- (a) reduce hysteresis loss due to burring of edges
(b) reduce eddy current loss due to burring of edges
(c) give mechanical strength to the core.
(d) increase core permeability.
181. The voltage regulation of a transformer with negligible resistance and 10% reactance at 0.8 p.f. lead is
- (a) 6% (b) 8%
(c) - 6% (d) - 8%.
182. In a dc machine, the polarity of the interpole is
- (a) same as that of the main pole ahead for both the generators and motors.
(b) same as that of the main pole behind for both the generators and motors.

(c) same as that of the main pole ahead for the generators and that of the main pole behind the motor.

(d) same as that of the main pole behind for the generator and that of the main ahead of the motor.

ANSWERS

1. (a)	2. (c)	3. (d)	4. (d)	5. (c)	6. (d)
7. (c)	8. (d)	9. (d)	10. (a)	11. (c)	12. (c)
13. (b)	14. (b)	15. (d)	16. (c)	17. (c)	18. (b)
19. (c)	20. (c)	21. (c)	22. (c)	23. (d)	24. (c)
25. (c)	26. (b)	27. (d)	28. (c)	29. (b)	30. (c)
31. (b)	32. (a)	33. (b)	34. (a)	35. (d)	36. (d)
37. (c)	38. (c)	39. (b)	40. (c)	41. (c)	42. (d)
43. (d)	44. (d)	45. (d)	46. (d)	47. (c)	48. (a)
49. (c)	50. (b)	51. (b)	52. (c)	53. (d)	54. (a)
55. (c)	56. (d)	57. (c)	58. (d)	59. (b)	60. (c)
61. (c)	62. (b)	63. (d)	64. (c)	65. (b)	66. (c)
67. (c)	68. (b)	69. (c)	70. (d)	71. (c)	72. (b)
73. (a)	74. (c)	75. (a)	76. (b)	77. (b)	78. (b)
79. (a)	80. (d)	81. (a)	82. (b)	83. (b)	84. (a)
85. (c)	86. (a)	87. (a)	88. (a)	89. (c)	90. (c)
91. (b)	92. (c)	93. (c)	94. (a)	95. (d)	96. (b)
97. (a)	98. (d)	99. (c)	100. (d)	101. (c)	102. (b)
103. (a)	104. (a)	105. (d)	106. (c)	107. (c)	108. (a)
109. (b)	110. (c)	111. (c)	112. (b)	113. (c)	114. (d)
115. (b)	116. (c)	117. (d)	118. (b)	119. (c)	120. (d)
121. (c)	122. (b)	123. (a)	124. (b)	125. (b)	126. (b)
127. (b)	128. (c)	129. (b)	130. (c)	131. (b)	132. (d)
133. (d)	134. (d)	135. (a)	136. (c)	137. (a)	138. (d)
139. (c)	140. (b)	141. (a)	142. (b)	143. (a)	144. (a)
145. (c)	146. (b)	147. (a)	148. (b)	149. (b)	150. (a)
151. (c)	152. (b)	153. (b)	154. (d)	155. (b)	156. (c)
157. (b)	158. (a)	159. (c)	160. (b)	161. (c)	162. (b)
163. (b)	164. (c)	165. (c)	166. (c)	167. (b)	168. (d)
169. (a)	170. (a)	171. (c)	172. (b)	173. (d)	174. (a)
175. (b)	176. (a)	177. (b)	178. (d)	179. (b)	180. (b)
181. (c)	182. (a)				

REFERENCES

1. Langsdorf A.S., Theory of alternating current Machinery, McGraw Hill 1955.
2. Wadhwa C.L., Network Analysis, New Age International Publishers 2004.
3. McPherson George & Laramore Robert D., An Introduction to Electrical Machines & Transformers John Wiley & Sons 1990.
4. Fitzgerald A.E. and Kingsley C., Electric Machinery 2nd edition McGraw Hill 1961.
5. V. Del Toro, Principles of Electrical Engineering Prentice Hall.
6. Golding E.W., Electrical Measurements and Measuring Instruments SIR ISAC PITMAN & SONS 1960.
7. Hayt W.H. Jr. and Jack E. Kemmerly, Engineering Circuit Analysis McGraw Hill.

**This page
intentionally left
blank**

www.EasyEngineering.net
ENGINEERING
© Apprise Education, Reprise Innovations ©

Index

A

A.C. circuits, 49
 Admittance, exciting, 206
 Air gap, 245, 277
 All-day efficiency, 224
 Amortisseur winding, 293
 Armature, 246
 Armature reaction
 d.c. machines, 248
 synchronous machines, 283
 Auto transformer, 232
 saving in copper, 232
 Auxiliary winding, 331
 Average value of waveforms, 52

B

Breadth factor, 279
 Brushes, 245

C

Capacitor
 start motor, 332
 start and run motor, 334
 Centrifugal switch, 332
 Condenser synchronous, 294
 Compound dc machines, 255
 cumulative, 255
 differential, 255
 flat, 259
 long shunt, 255
 short shunt, 255
 under compounded, 259
 Commutation, 251
 Compensating winding, 253
 Constant losses, 266

Copper loss, 266
 Core loss, 266
 Counter emf, 248, 291
 creep, 198
 Coupled circuits, 102
 Cylindrical rotor, 277

D

Damper winding, 292
 D.C. machines, 245
 Delta connection, 169
 Delta star transformation, 122
 Distribution systems, 343
 Dot convention, 102

E

Eddy current loss, 222
 Effective value, 54
 Efficiency
 alternator, 287
 of dc machines, 267
 of transformer, 222
 Energy meters, 196
 Equivalent circuit
 of induction motors, 206
 of transformer, 210
 Exciting current, 206

F

Faraday's laws, 205
 Field rotating magnetic, 280, 305
 Field winding, 245, 277
 Fleming's right-hand rule, 249
 Form factor, 55
 Frequency, 276
 Friction and Windage, 266

G

- Generator d.c., 258
 - compound, 259
 - series, 258
 - shunt, 258
- Generation
 - conventional, 357
 - non-conventional, 352

H

- Half power frequency, 76
- Hunting, 292
- Hysteresis loss, 221

I

- Ideal transformer, 205
- Inductance, 58
- Induction meters, 186
- Induction motors, 304
 - maximum torque, 310
 - output power, 308
 - rotor copper loss, 309
 - speed control, 310
 - starting current, 216
 - starting torque, 316
- Interpoles, 253

K

- Kirchhoff's laws, 111

L

- Leakage reactance, 207
- Linear system, 134
- Loop analysis, 125
- Loop impedance matrix, 128
- Losses
 - dc motors, 266
 - transformer, 221

M

- Magnetic circuits, 91
- Magnetic field intensity, 91
- Magnetising current of transformer, 206
- Magnetisation curve, 257

- Magnetomotive force, 92
- Main winding, 331
- Maximum efficiency of transformer, 224
- Maximum power transfer theorem, 144
- Measurement of 3-phase
 - active power, 172
 - reactive power, 176
- Mesh equations, 125
- Millman theorem, 165
- Moving coil meters, 182
- Moving iron meters, 185
- Mutual flux, 207
- Mutual inductance, 105

N

- Network theorem, 134
- Nodal admittance matrix, 133
- Nodal analysis, 130
- No load test of transformer, 214
 - alternator, 284
- Norton's theorem, 140

O

- Oersted, 91
- Open circuit test of transformer, 214
- Open circuit test of alternator, 284

P

- Parallel resonance, 80
- Peak factor, 56
- Permanent magnet stepper motor, 299
- Phantom load, 200
- Phase, 51
- Phasor diagram, 56
- Pitch factor, 279
- Polarity of a transformer, 228
- Polyphase energy meters, 199
- Power angle, 290
- Power factor, 61, 349
 - low, causes, 349
- Power factor improvement, 347
- Power supply system, 344
- Power system, 342
- Pull out torque, 290

Q

- Q-factor, 74
- Q of parallel RLC circuit, 85

R

- Reactive power measurement, 176
- Regulation voltage in transformer, 217
- Resistance starting, 317
- Resonance, 69
 - parallel, 80
 - series, 70
- Relative permeability, 91
- Reluctance, 94
- RMS value, 54
- Rotor speed, 305
- Rotating magnetic field, 280
- Round rotor, 277

S

- Salient pole rotor, 277
- Scale of meters, 184
- Self inductance, 105
- Series motor d.c., 264
- Series resonance, 70
- Shaded pole motor, 334
- Short circuit test, 215, 285
- Shunt, 188
- Shunt motor, 262
- Single phase induction motors, 328
- Slip, 305
- Slip frequency, 305
- Slip ring, 305
- Slip ring I.M., 305
- Split phase motor, 331
- Star connection, 164
- Star delta, transformation, 122
- Starting
 - D.O.L., 316
 - induction motor, 315
- Single phase IM, 331
- Star delta, 317
- Synchronous motor, 276
- Stepper motors, 299
- Superposition theorem, 134

- Swinburne Test, 268
- Synchronous condenser, 294
- Synchros, 337
- Synchronous machines, 277
- Synchronous motor starting, 292
- Synchronous impedance, 286
- Sumpner's test, 231

T

- Tachometer
 - ac, 338
 - dc, 338
- Tesla, 91
- Thevenin's theorem, 136
- Three phase circuits, 160
- Three phase transformer, 230
- Three point starter, 265
- Three wattmeter method, 172
- Torque angle, 290
- Torque-slip characteristic, 320
- Transformers, 203
 - core type, 204
 - emf equation, 205
 - shell type, 204
 - testing, 231
- Two phase motors, 334
- Two phase servo motor, 337
- Two wattmeter method, 173

U

- Universal motor, 335

V

- V-curves, 331
- Voltage regulation
 - alternators, 286
 - transformers, 217

W

- Wattmeters, 192
 - Dynamometer, 192
 - Induction, 193
- Windage loss, 266
- Wound rotor, 304